

# Real Time Vehicle and Environment Monitoring in Smart Cities

Sharanya P S<sup>1</sup> Shilpa Shetty<sup>2</sup>

<sup>1,2</sup>Department of Information Science & Engineering  
<sup>1,2</sup>AJ Institute of Engineering and Technology, Mangalore, India

**Abstract**— In this paper, the use of sensor networks in environmental monitoring and vehicle monitoring, which are important in a smart city. The connectivity provided by WiFi are needed to realize the concept of Internet of Things (IoT). The main cause of environmental pollution in most cities are industries and automobiles emitting different types of poisonous gases. This paper discusses the implementation of a unit which senses the presence of gases and uploads the information to a website. The second part of this work is a vehicle monitoring unit that can be fixed in vehicles. This system tracks the vehicle and monitors its engine temperature and the presence of poisonous gases. In the case of the vehicle is stolen, it will be tracked and a message is sent to the owner. An Android app is developed so that all the required information is easily available. The paper describes the hardware and software implementation of the prototype system.

**Keywords:** Smart cities, Internet of Things, Wireless Sensor networks, Traffic management, Smart vehicle

## I. INTRODUCTION

Wireless sensor network (WSN) is an integral part to implement the concept of Internet of Things (IoT), which has affected all the aspects of our life. The concept of IoT has led to the design and development of connected devices, which can perform the functions of sensing, monitoring. One important application area of IoT is smart cities. Many cities of the world are rapidly introducing sensor based connected networks towards this goal.

## II. RELATED WORK

Environmental monitoring, and vehicle monitoring come under the scope of the design of smart cities using WSNs[1]. Here it discusses the importance of measuring temperature and keeping track of vehicle details [2]. The RFID is used to keep track of vehicle details and also for tracking stolen vehicles [3]. vehicle emission is tracked by using gas sensor, in which the higher emitting vehicles are identified and messages are sent to the vehicle owners from a control station [4].

## III. METHODOLOGY

The functionalities of the project are listed below

### A. Environmental monitoring

- Air pollution monitoring
- Vehicular emission tracking
- Temperature measurement

### B. Vehicle monitoring

- Tracking of stolen vehicle
- Engine temperature

The system consists of two units, namely Control Unit and Vehicle unit. The control unit is a hardware unit which is

placed at traffic junctions, while the vehicle unit is meant to be attached to vehicles.

### 1) The Control Unit

The control unit majorely monitors air pollution. All information taken from the sensors is uploaded to the web application. Traffic management is also done by the control unit in tandem with the IR sensors placed at the dividers of the road. It senses the density of the traffic and through the website gives the information about the level of traffic congestion and sends the message to the higher authority. If the vehicles have been stolen and the user have added into stolen list it will be stored in stolen record when the stolen vehicle is passed by any traffic junction were this control unit is placed it will read the RFID tag number and tracks the vehicle and sends the message to the vehicle owner and takes the further actions. Fig. 1 shows the flow chart of the working of the control unit.

### 2) The Vehicle Unit

Its most important components are the gas and temperature sensors to measure the temperature, and the level of CO gases in the exhaust of the vehicle. The system is programmed in such a way that when a vehicle is at a junction, emission levels that are sensed are sent to the web through the control unit and if the value is above the permitted level, a message is sent to the authorities and to the vehicle owner. The control unit uploads this information to the website for reference and record. Figure 2 shows the flow chart of the working of the vehicle unit, which is to be present in all the vehicles.

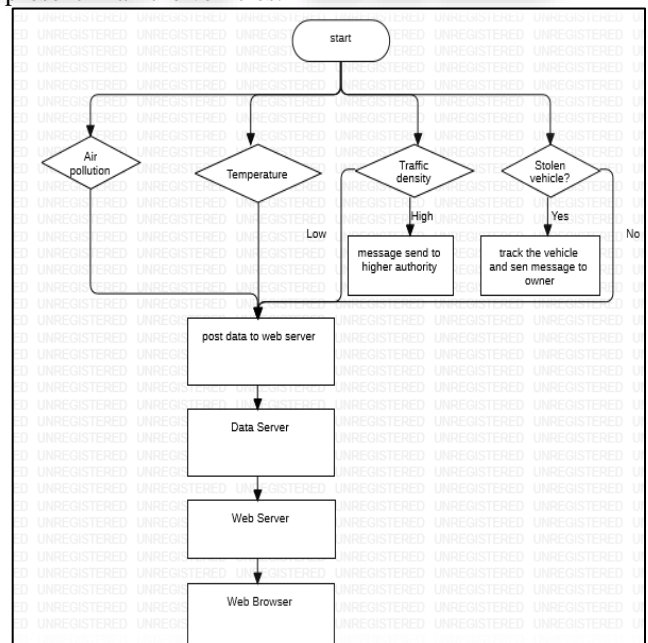

Fig. 1: Flow chart showing the working of the control unit  
 Retrieving a vehicle information if it is stolen, initially, the owner must register his vehicle into the system using his mobile number.

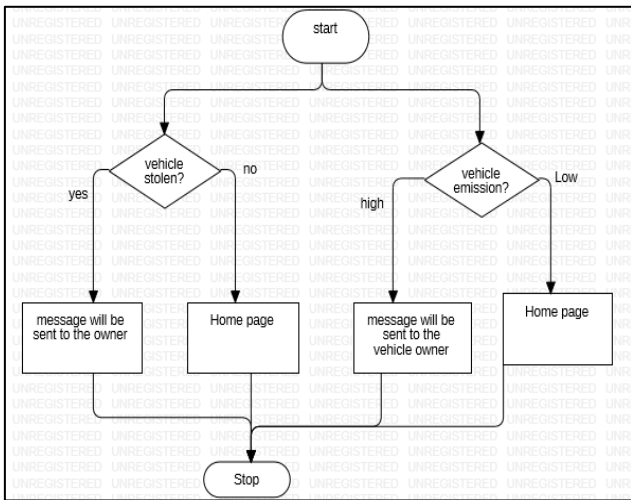

Fig. 2: Flow chart for the operation of the vehicle unit

#### IV. RESULTS AND DISCUSSION

##### A. The Control Unit

It has a high end embedded processor and sensors. This unit may be placed at all traffic junctions, which is a convenient point to place it. The control unit is the central unit from where information goes to the governing authorities through the website. many more sensors. The board have Wi-Fi connectivity. Figure 3 shows the block diagram of the Control unit. CO(carbon monoxide) sensor, are gas sensor for monitoring the quality of air. The Wifi module is used to communicate with the vehicle unit. There is an RFID reader in this unit, which reads the RFID tag of the vehicles at the junction. Figure 4 shows the overview of the control unit. It includes the circuit board used with different componets.

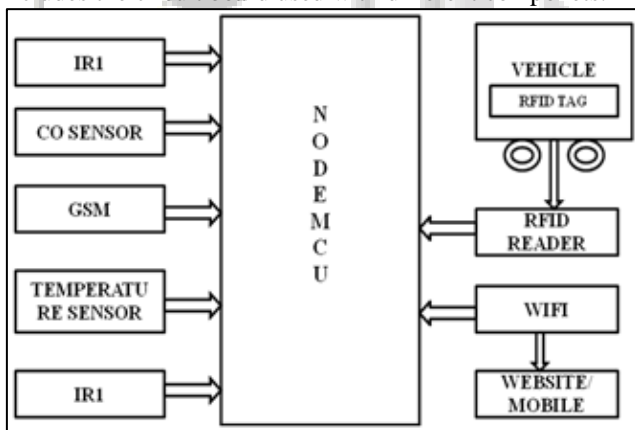

Fig. 3: The block diagram of the control unit

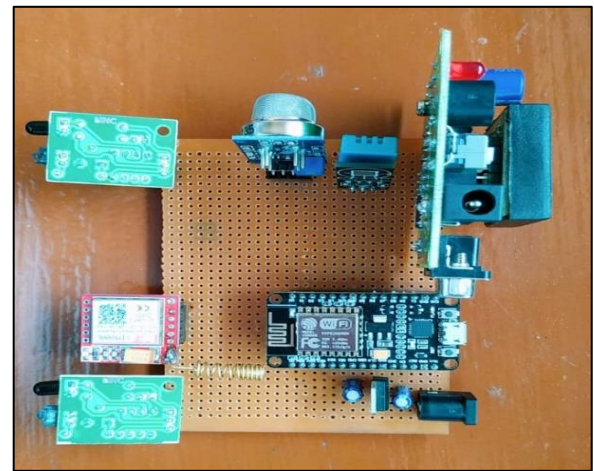

Fig. 4: Overview of the control unit

##### B. The Vehicle Unit

Figure 5, shows the block diagram of the vehicle unit. This unit uses NodeMCU and has sensors and actuators to implement the functions shown in the flow chart in Fig.2. Communication between the control unit and the vehicle unit is done using the Wifi module. It has a temperature sensor for measuring engine temperature and a gas sensor for sensing the presence of poisonous gases in the engine exhaust. The GSM module sends alerts and notifications to the mobile numbers of the owner. Figure 6 shows the different components embedded in the Vehicle unit

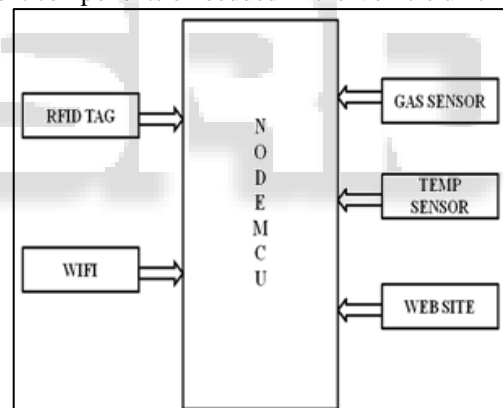

Fig. 5: The block diagram of the vehicle unit

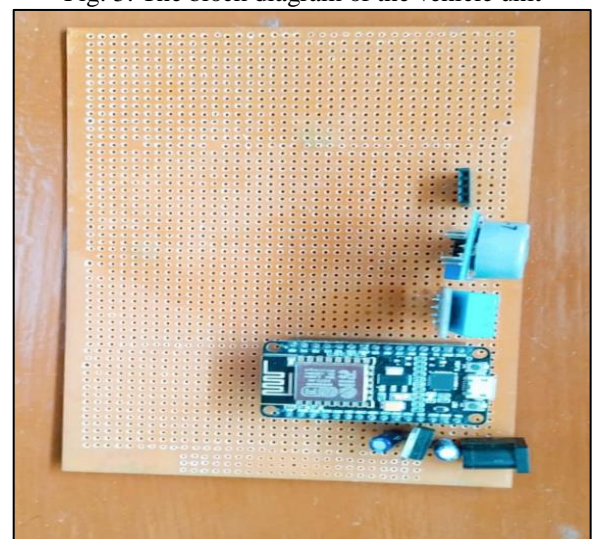

Fig. 6: Overview of Vehicle unit

### C. Traffic Management

To measure the traffic density, this system uses a series of ultrasonic sensors which are placed on the dividers by maintaining equal distance between two sensors. These sensors give binary values to the microcontroller. If all sensors give 'one', it is understood that the traffic density is high. If only a few sensors give a high, it is taken as low traffic density. Messages are put up in the website accordingly. Fig. 5 shows the placement of the sensors along the dividers of the road.

### D. Software Design

The Web server is designed with PHP as back end and HTML, CSS (Cascaded Style Sheet) and JavaScript for the front end. The controller in the control unit is connected to the internet and posts data to the web server continuously. The Web server has different web services for each task. When data is posted to a web service (using the http protocol), data validation is done and data is saved in the data server, which has an SQL database. The communication between the database and the web server is established using a PHP SQL connector. Data is well structured and maintained in the database for easy data extraction based on area/vehicle number. When a user opens the browser and accesses the website, it shows all the data taken from the data server based on user input. HTML is used to display the webpage and CSS is used to add styles to the web pages. An android app has been developed, using Android Studio for better user experience, which extracts important data from the web server and alerts the user about traffic and pollution details.

## V. CONCLUSION AND FUTURE WORK

This paper focuses on some important aspects that need attention when a comprehensive scheme for IoT based city management is envisaged. The most important point in IoT for cities is that the smartness is to be achieved with the least amount of human intervention. Machine-to-machine communication and Machine to-infrastructure communication is the two essential requirements in a smart city project. This requires highly reliable networks and low power sensors and equipment's. Once this is done, systems for monitoring and controlling, as in this paper, may be easily integrated into the infrastructure of the city and citizens will learn to use these systems.

## REFERENCES

- [1] D. Rahul Naik1, Lyla B. Das, Bindiya T. "Wireless Sensor networks with Zigbee and WiFi for Environment Monitoring, Traffic Management and Vehicle Monitoring in Smart Cities" IEEE 3rd International Conference on Computing, Communication and Security (ICCCS), ISBN: 978-1-5386-6227-4 2018.
- [2] Zanella A., Bui N., Castellani A., Vangelista L. and Zorzi M.. "Internet of Things for Smart Cities". IEEE Internet of Things Journal, 1 (1), 2232, 2014
- [3] Yongjun Z., Xueli Z. and Shuxian Z., "Intelligent transportation system based on Internet of Things". In

World Automation Congress (WAC), pp. 1-3. June 2012.

- [4] Vong C.M., Wong P.K., Ma Z.Q. and Wong K.I., "Application of RFID technology and the maximum spanning tree algorithm for solving vehicle emissions in cities on internet of things", IEEE World Forum on Internet of Things (WF-IoT), pp. 347-352, March 2014.