

REFERENCE COPY

# HAND BOOK OF ENVIRONMENTAL ENGINEERING

(Solid Waste Management - Part A)

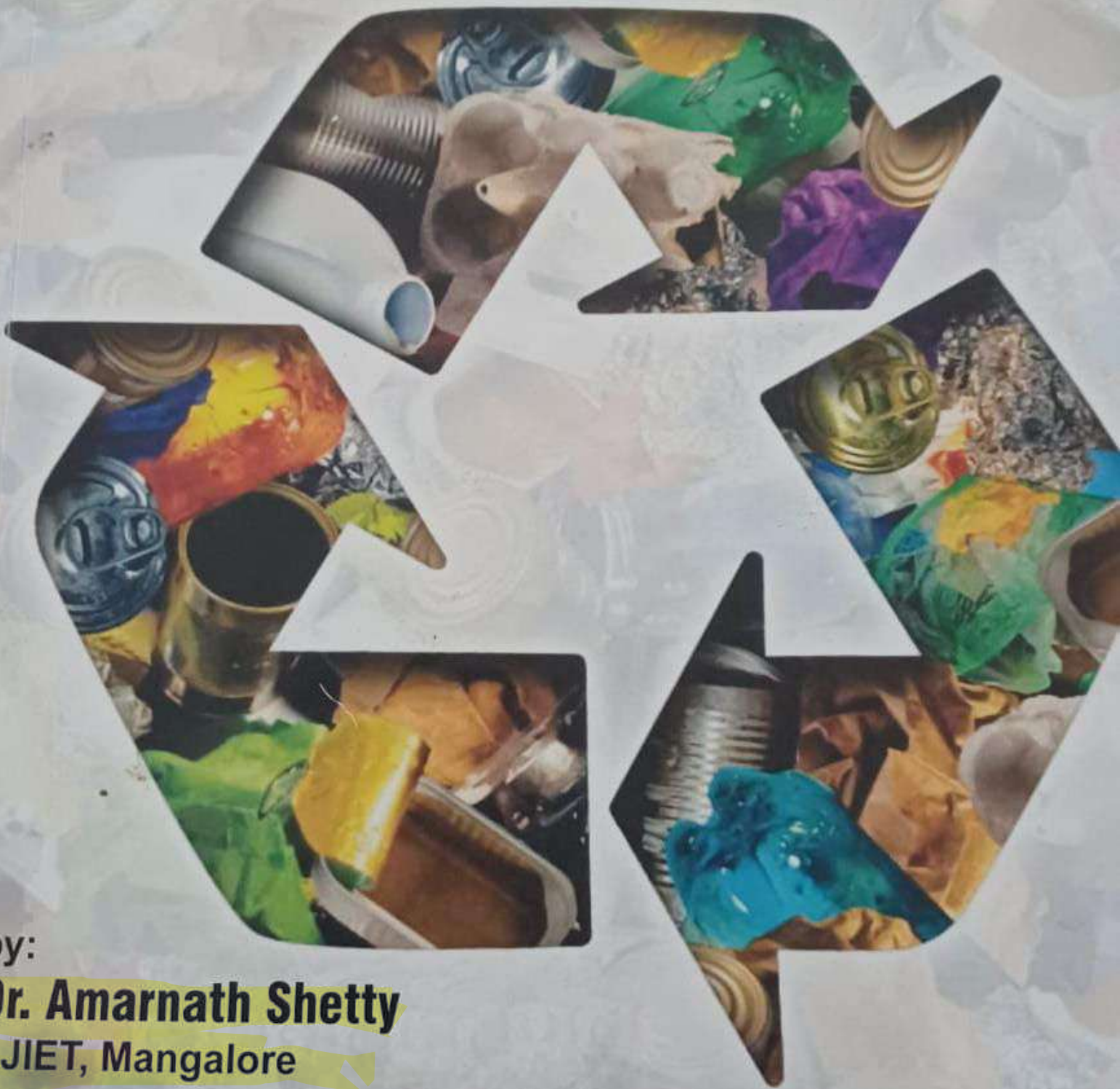

by:

**Dr. Amarnath Shetty**

AJIET, Mangalore

**About Author:**

**Dr. Amarnath Shetty** BE, M.Tech, P.h.D.

Presently working as an Professor in the department of  
Civil Engineering at AJIET, Mangalore.

**Pristine Publishing House**  
Mangalore

ISBN : 978-81-93783-81-4



# **SOLID WASTE MANAGEMENT**

## **➤ Module 1**

Sources: Sources of Solid waste, Types of solid waste, Physical and Chemical composition of municipal solid waste, Generation rate, Numerical Problems.  
Collection: Collection of solid waste- services and systems, equipment's.  
Transportation: Need of transfer operation, transfer station, transport means and methods, route optimization. Solid waste management 2000 rules with, 2016 amendments.

## **➤ Module -2**

Processing techniques: Purpose of processing, Chemical volume reduction (incineration) – Process description, 3T's, principal components in the design of municipal incinerators, Air pollution control, Mechanical volume reduction (compaction), Mechanical size reduction (shredding), component separation (manual and mechanical methods).

## **➤ Module -3**

Composting Aerobic and anaerobic method - process description, process microbiology, design consideration, Mechanical composting, Vermicomposting, Numerical Problems.

Sanitary landfilling: Definition, advantages and disadvantages, site selection, methods, reaction occurring in landfill- Gas and Leachate movement, Control of gas and leachate movement, Design of sanitary landfill, Numerical Problems.

## **➤ Module -4**

Sources, collection, treatment and disposal of: biomedical waste, E-waste, Hazardous waste and construction waste.

## **➤ Module -5**

Incineration -3Ts factor affecting incineration, types of incinerations, Pyrolysis, design criteria for incineration Energy recovery technique from solid waste management.

# MODULE-1

## **Solid Waste:**

**Definition:** “Solid wastes are all the waste from human and animal activities that are normally solid and that are discarded as useless, unwanted. It encompasses the heterogeneous mass of throw away from residences and commercial activities as well as more homogeneous accommodations of a single industrial activity”

## **Solid Waste Management:**

"The discipline concerned with the control of solid waste generation, storage, collection, transfer, and disposal in a manner, i.e. in accordance with best practices of public health, economics, engineering, conservation, aesthetics, and other environmental considerations and that is also responsive to public attitudes." All administrative, financial, legal, planning, and engineering aspects are covered by its purview.

Functions involved in solutions to all problems of solid waste.

1	Special waste,Source	Typical facilities, activities or locations where waste are generated	Types of solid waste
2	Rubbish Residential	Single family and multi-family dwellings; low, medium and high raise apartments, etc.,	Food waste rubbish ,ashes, special waste
2	Commercial	Stores, restaurants, market, office, buildings, hotels, print shops, auto repair shops, and medical facilities.	Food waste, rubbish ,Ashes, demolition and construction waste,

3	Open areas	Streets, parks, playgrounds vacant slots, beaches, highways, recreational areas, etc.	Special waste, Rubbish
4	Demolishing and construction waste	Waste from residential buildings and other structures; Waste from the construction, remodeling and Repairing of residential, commercial and industrial building and similar	Structures are classified as construction waste. These wastes may include dust, stones, concrete, bricks, plaster; Plumbing, heating and electrical parts.
5	Special waste	Waste such as street sweeping, roadside litter, catch basin debris, dead animals and from abundant vehicles.	Classified as special waste.
6	Treatment plant waste	The solid and semi-solid waste from water, waste water and industrial waste treatment facilities are included in This classification.	Classified as special waste.

## 1. Physical and Chemical Composition of Municipal Waste.

**Importance:** Information on properties of solid waste is important in evaluating alternative equipment needs, system and management programmers' and plans especially to the implementation of disposal; and resource and energy recovery operations.

### Properties of Solid Waste:

#### ➤ Physical Composition Properties:

- a) Individual components
- b) Particle size
- c) Moisture content
- d) Density

#### a) Individual components



Moisture	Volatile matter	Ash	Fixed carbon
(loss at 105 <sup>0</sup> c For 1 hour)	(Additional loss on ignition at 950 <sup>0</sup> c)	(Residue after Burning)	(Residue after Burning)

### Individual Components of MS:

Sl no	Component	% Or Mass (Typical Values)
1	Food waste	14
2	Paper	34
3	Card board	07
4	Plastic	05
5	Textiles	02

6	Rubber	05
7	Leather	05
8	Garden Trimming	02

**b) Particle size**

The recovery of materials, particularly when using mechanical methods like magnetic separators, must take into account the size distribution of the constituent materials in solid waste because there are significant differences among the different measures of size that will give the data required for a given application.

**c) Moisture contents**

The moisture content of solid waste is commonly expressed as the mass of moisture per unit mass of weight of wet or dry material. When employing the wet mass technique of measurement, the moisture in a sample is expressed as a percentage of the wet mass of the substance.

When utilizing the dry mass approach, it is specified as a percentage of the material's dry mass. The equation for the wet mass moisture content reads as follows.

$$\text{Moisture content (\%)} = \frac{a - b}{a} \times 100$$

Where,

‘a’ = initial mass of sample as delivered  
‘b’ = mass of sample after drying

The wet weight method is used most commonly in the field of SWM. To obtain the dry mass, the solid waste material is dried in a oven at 770 c(170<sup>0</sup> F) for 24 hours. This temperature and time are used to dehydrate the material completely and to limit the vaporization of volatile materials.

**d) Density**

The density of solid waste varies markedly with geographic location, season of the year, length of time in storage. Great care should be used in selecting the typical values.

➤ **Chemical Composition Or Properties:**

- a) Proximate Analysis
- b) Fusing point of Ash
- c) Ultimate Analysis –Percentage of C, H, O, N, S and Ash
- d) Heating value (Energy value)

**1. Proximate Analysis:**

Proximate analysis for the contributable components forMSW includes the following tests.

a	Moisture	-When heated to 105 <sup>0</sup> C for 1 hour.
b	Volatile combustiblematter	-Additional loss of weight at 950 <sup>0</sup> C in a coveredcrucible.
c	Fixed carbon	- Combustible residue left after volatile matter is removed.
d	Ash	- Weight of residue after combustion in a open crucible.

**Energy Content:**

Equations for the Calculation of Energy Content:

Energy values may be converted to a dry basis by following

$$KJ/Kg = KJ/Kg = \frac{100}{100 - \% \text{ moisture}}$$

(Dry Basis)(As Discarded) 100 - % moisture

The corresponding equation on ASH FREE DRY BASIS is =100

100- % Ash- % Moisture

**Chemical Content:**

If energy values are not available, approximate values may be determined by using an equation known as modified Dulong formula as given below.

$$\text{KJ/Kg} = 337\text{C} + 1420[\text{H} - \text{O}/8] + 95\text{S}$$

Where

C= % Carbon

H= % Hydrogen

O= % Oxygen

S= % Sulphur

### **Data Collection and Collection Rates**

Factors that affect waste generation rates:

- 1) Source reduction and recycling activity
- 2) Public attitudes and litigation
- 3) Chemical and physical factors on generation of solid waste

### **Source Reduction and Recycling Activities:**

Waste reduction can be achieved by creating products that use the least amount of harmful materials, have a long shelf life, and are designed, manufactured, and packaged accordingly. By using items and materials more wisely, waste reduction can also take place in residential, commercial, and industrial settings.

Although source reduction is not currently a significant component of waste reduction, it is likely to play a significant role in future efforts to improve the quality of waste produced.

Source reduction can be achieved by some ways.

- 1) Decrease unnecessary and excessive packaging.
- 2) Develop and use products with greater durability and repeatability.
- 3) Substitute reusable products for disposal single use products.
- 4) Use few resources
- 5) Increase recycled materials.

## **Public Attitudes and Legislation:**

### **Public Attitude**

Ultimately, significant reduction in the quantities of solid waste generated occurs when and if people are willing to change their habits and life style to conserve the natural resources and to reduce the economic burden associated with the management of solid waste. A program is continued education is essential in bringing about change in public attitudes

### **Legislation:**

Perhaps the most important factor affecting use generation of certain types of waves is use of local, state. Encouraging purchase and use of regarded.

## **Effect of Geographic Of Physical Factors On Waste Generation**

The location, time of year, use of kitchen water, food grinders, frequency of garbage collection, and characteristics of the service area are only a few of the geographical and physical elements that determine the amounts of waste produced and collected. The effect of these elements must be assessed in each generation because general generational value is low.

## **Methods Used To Estimate Waste Quantities:**

On the basis of information acquired during waste characterization studies using data from prior trash creation or a combination of two methodologies, waste quantities are typically approximated.

- 1) Load count analysis
- 2) Volumetric weight analysis
- 3) A material balance assessment

➤ **PROBLEMS:**

1. Estimate the moisture content of a solid waste sample with the following composition, that moisture content of the following components, food waste = 70%, paper=6%, card board=5%, plastic=2%, Textile=10%, Rubber=2%, Leather=10%, Miscellaneous organics =30%.

Note: Based on 100kg sample of waste.

COMPONENT	% BYMASS
Food waste	18
Paper	34
Card Board	07
Plastic	15
Textile	12
Rubber	02
Leather	02
Miscellaneousorganics	10

**Solution**

COMPONENT	% BY MASS	% MOISTURE CONTENT	DRY MASS (KG)
-----------	--------------	-----------------------	---------------

Food waste	18	70	$\frac{30 \times 18}{100} = 5.4 \text{ Kg}$
Paper	34	06	$\frac{94 \times 34}{100} = 31.96 \text{ Kg}$
Card Board	07	05	$\frac{95 \times 07}{100} = 6.65 \text{ Kg}$

Plastic	15	02	$\frac{98 \times 15}{100} = 14.7 \text{ Kg}$
Textile	12	10	$\frac{90 \times 15}{100} = 10.8 \text{ Kg}$
Rubber	02	02	$\frac{98 \times 2}{100} = 1.96 \text{ Kg}$
Leather	02	10	$\frac{90 \times 2}{100} = 1.8 \text{ Kg}$
Miscellaneous Organics	10	30	$\frac{70 \times 10}{100} = 7 \text{ Kg}$
			<b>Total Dry = 80.27 Kg Mass</b>

$$\text{Moisture Content} = \frac{a-b \times 100}{a}$$

$$= \frac{100 - 80.27 \times 100}{100}$$

$$\text{Moisture Content} = \underline{19.73\%}$$

2. Estimate unit weight content KJ/Kg of a solid waste sample with following compositions. Given that energy content is in KJ/Kg.

COMPONENT	ENERGY CONTENT (KJ/KG)
Food waste	20
Paper	30
Card board	11
Plastic	14
Textile	10
Rubber	03
Leather	04
Miscellaneousorganics	08

COMPONENT	ENERGY CONTENT (KJ/KG)
Food waste	4650

Paper	16300
Card board	16300
Plastic	32600
Rubber	23250
Textile	17450
Miscellaneous organics	18000

COMPONENT	BY MASS	CONTENT (KJ/KG)	MASS (KG)
Food waste	20	4650	93000
Paper	30	16300	489000
Card board	11	16300	179300
Plastic	14	32600	456400
Textiles	10	17450	174500
Rubber	03	23250	69750
Leather	04	17450	69800
Miscellaneous Organics	08	18000	144000

Total unit energy content = 16, 75,750 KJ (Based on 100Kg of sample)

Unit Energy content =  $\frac{1675750 \text{ KJ}}{100 \text{ K}}$

$$= 16757.50 \text{ KJ/K}$$

## Waste Collection and Separation

Because residential, commercial, and industrial solid garbage is produced in every house, apartment, business or industrial facility, street, park, and even vacant places, collection and separation of solid waste in urban areas is challenging and complex. The proliferation of suburbs and satellite towns across the nation has made the collection process even more challenging.



### Types of Collection Services:

The various types of collection services are

Municipal collection services

- a) From low rise detached dwellings
- b) From low and medium rise apartments
- c) From high rise apartments

## Municipal Collection Services or Residential Collection Services:



It varies depending upon the type of dwelling units. Collection for low rise detached dwellings and collection for medium and high rise apartments are considered separately.

The most common types of residential services used in various parts of the country include

- I. Curb
- II. Alley
- III. Set out- set back
- IV. Set out
- V. Back yard carrying

Where curb service is used, home owner is responsible for placing the containers to be emptied at the curb on collection day and for returning the empty containers to their storage location until the next collection. Where alleys are part of the mask layer of a city of a given residential area, alley storage of containers, used for solid waste is common. In set out- set back service, containers are set out from the owner's property and set back after being emptied by additional crews. set out service is essentially the same as set out- set back service, except that the home owner is responsible for returning the containers to their storage locations. In backyard carrying service, the collection crew is responsible for entering the owner's

property and removing the waste from their storage locations.  
Method of loading the collection vehicle may be either manual or mechanical.

### **Commercial and Industrial Services:**



Both manual and mechanical means are used to collect waste from commercial facilities. To avoid traffic congestion, during the day, solid waste from commercial establishments in many cities is collected in the late evening and early morning hours.

Where manual collection is used, wastes are put into plastic bags, cardboard boxes and other disposable containers that are placed at the curbs for collection. If congestion is not a major problem, and space for strong containers is available, the collection service is provided to these center's on the use of movable containers, containers that can be coupled to large stationary containers. The contents of the container may be emptied mechanically to the loaded containers hauled to a offside location where the contents are unloaded.

## Types of Collection Systems:

Based on their mode of operation, collection systems are classified into 2 categories.

1. Hauled Container Systems
2. Stationary Container Systems

### 1. Hauled Container Systems

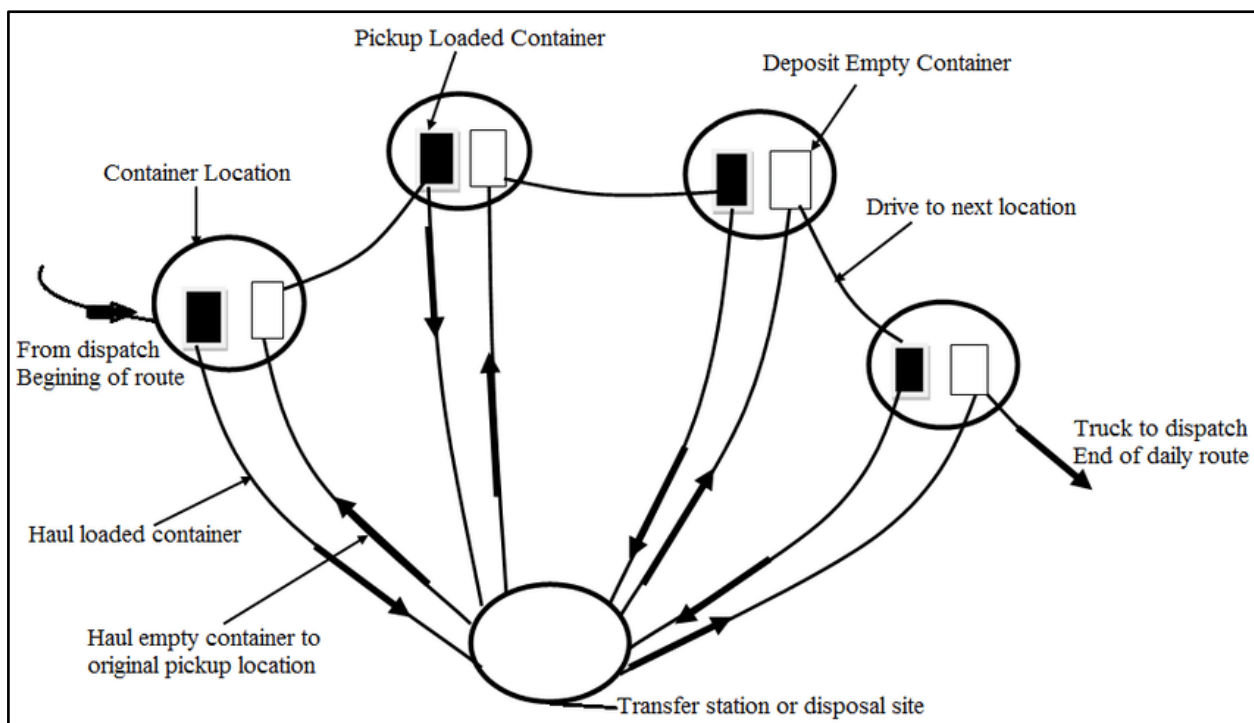

Collection systems in which containers used for the storage of waste are hauled to the processing, transfer and disposal site; emptied and returned to their original location or some other location, are defined as hauled container system (HCS).

There are 2 types of HCS

- i) Tilt frame containers
- ii) Thrash trailers

The collector is responsible for driving the vehicle, loading empty

containers and unloading full containers and emptying the content of the containers at disposal site. In some cases, for safety reasons, both helper and driver are used. Systems that use tilt frame loaded vehicles and large containers often called drop boxes are ideally suited for the collection of the solid waste from location where generation rate is very high.

### 3. Stationary Container Systems

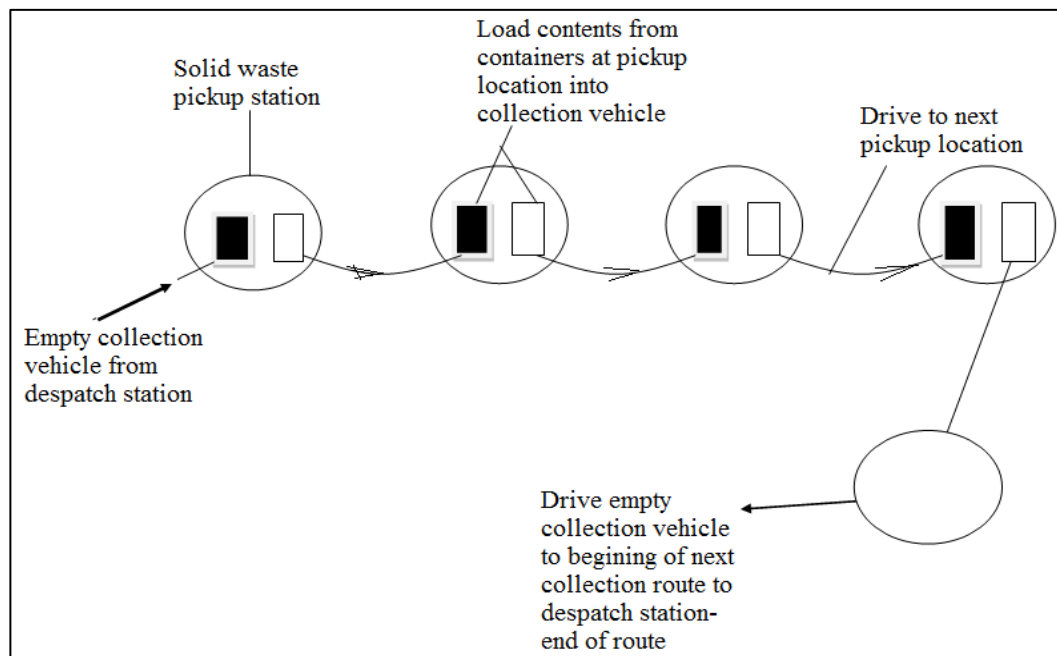

Collection system in which containers used for the storage of waste remain at the point of waste generation except when moved for collection are defined as stationary container system. Labor requirements for mechanically loaded for SCS are essentially same as HCS.

These are two types of SCS.

- i) Those in which self-loading compactors are used.
- ii) Those in which manually loaded vehicles are used.

Containers size and utilization are not as critical as in SCS using self-loading vehicles equipped with a compaction mechanism as they are in

HCS. Trips to the disposal site from the Transfer or processing station are made after the contents of the number of containers collected, compacted and collection vehicle is full. Because a variety of container sizes .

**Definition of Terms:**

TERM	HCS	SCS
Pick – Up	The time spent picking up the loaded container. The time required to redeposit the container after its contents have been emptied and the time spent driving to the next container.	The time spent loading the collection with the stopping of the vehicle prior to loading the contents of 1 <sup>st</sup> container and ending that the contents of the last container to be emptied have been loaded.
Haul	The time required to reach the disposal site, starting after a container whose contents are to be emptied has been loaded on the truck + (plus) the time after leaving the disposal site until the truck arrives at the location where the empty container should be redeposit (time spent at disposal site is not included)	The time required to reach the disposal site starting after the last container on the route has been emptied or the collection vehicle is filled +(plus) the time after leaving the disposal site until the truck arrives at the location of the first container to be emptied on the next collection route (time spent at the disposal site is not included)

At site	The time spent at the including time spent as well as unloading	Disposal site waiting to unload
Off Route	All the time spent non-productive from the overall collection offroute time includes.	On activities that are the point of view of operation.

- i) Time spent checking in and out in the morning and at the end of the day.
- ii) Time last due to unavoidable congestion.
- iii) Time spent on equipment repairs and maintenance

Un necessary off route time includes time spent for lunch in excess of stated lunch period and time spent on taking un authorized coffee breaks, talking to friends, etc.

**Transfer Means and Methods (Transport Methods)**

The main methods for moving garbage include automobiles, railroads, and ocean-going boats. Additionally, hydraulic and pneumatic systems have been applied. There are yet more recommended systems, most of which have not been tried.



➤ **Motor Vehicle Transports:**



Motor vehicle used to transport solid wastes on highways should satisfy the following requirements.

- i) Vehicles must transport waste at minimum cost.
- ii) Waste must be covered during the having operations.
- iii) Vehicles must be designed for highway traffic.
- iv) Vehicle capacity must be such that allowable weight limits are not exceeded.
- v) Methods used for unloading must be simple

➤ **Rail Road Transport:**



Although rail roads were commonly used for the transport of solid waste in the past, they are now used by only a few communities. However, renewed interest is again developing in the use of rail roads for hauling solid waste especially to remote areas where highway travel

➤ **Water Transport:**



Barrages, scows and special boards have been used in the past to transport solid waste to processing locations and to seaside and ocean disposal sites, but ocean disposal is no longer practiced by developed countries. Although some ship propelled vessels were once used, the most common practice was to use vessels towed by tugs or other special boards.

➤ **Pneumatic Transport:**

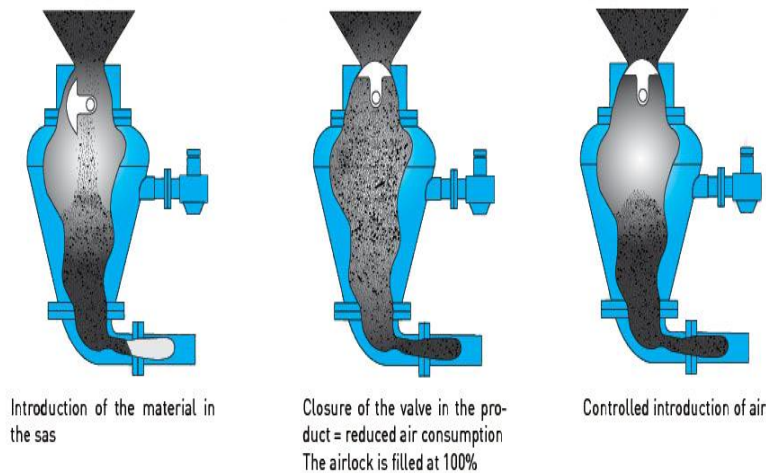

Low pressure, air and vacuum conduit transport systems have been used to transport solid waste. The most common application is the transport of waste from high density apartments or commercial activities to a central location for processing or for loading into transport vehicles. The largest pneumatic system now in use in United States is in the Walt Disney world amusement park in Florida.

**Transfer Station:**

Factors that must be considered in the design of transfer stations.

- Type of transfer operation to be used.
- Capacity requirement.
- Equipment and accessory requirements and
- Environmental requirements

## Types:

Depending on the method used, to load the transport vehicles, transfer stations may be classified into 3 types

- i) Direct discharge
- ii) Storage discharge
- iii) Combined direct and storage discharge

### ○ Direct Discharge:



In a direct discharge transfer station, waste from the collection vehicles usually is emptied directly into the vehicle to be used to transport them to a place of final disposal. To accomplish this, these stations usually are constructed in a two level arrangement. The unloading platform from which wastes from collection vehicles are discharged into the transport trailers which are elevated. Direct discharge transfer stations employing stationary compactors are also popular.

○ **Storage Discharge:**



In the storage discharge transfer station, wastes are emptied either into a storage pit or onto a platform from which they are loaded into transport vehicles by various types of auxiliary equipment. In a storage discharge transfer station, the various processing techniques like shredding, separation, magnetic separation of ferrous scraps, compaction, etc, are employed by using various types of auxiliary equipment's. In a storage discharge transfer station, the storage volume varies from 1 ½ to 2 days volume of solid waste.

○ **Combined Direct And Storage Discharge:**

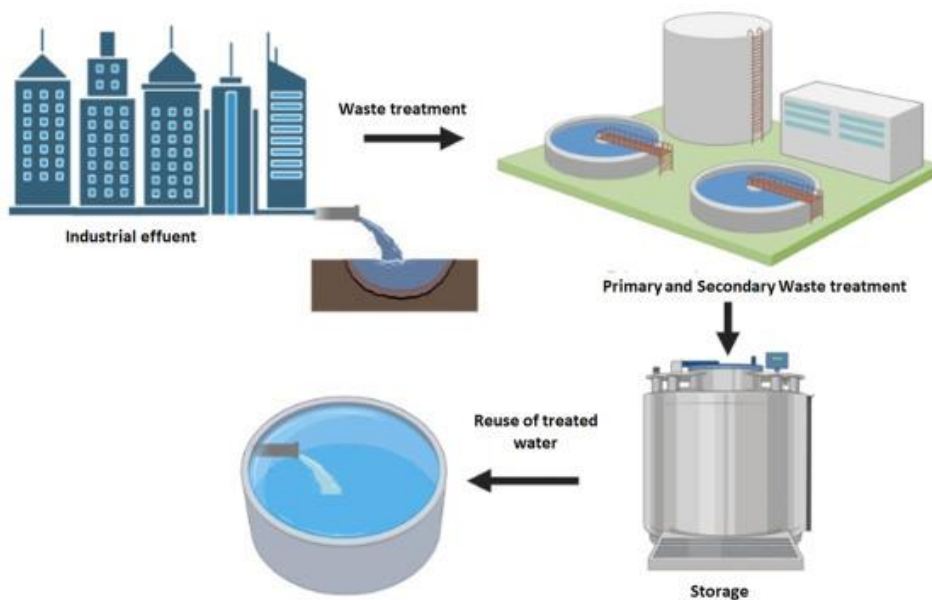

In some transfer stations, both the methods used. Usually, these are multipurpose facilities, designed to service a broader range of users than a single purpose facility. In addition to serving a broader range of in addition to serving a broader range of users, a multipurpose transfer station can also house a materials salvage (recovery) operations.

### **Capacity Requirements:**

The operational capacity of a transfer station must be such that the collection vehicles do not have to wait too long to unload. In most cases it will not be cost effective to design the station to handle the ultimate peak number of hourly loads. An economic trade off analysis should be made between the annual cost for the time spent by the collection vehicles waiting to unload against the incremental annual cost of a larger transfer station and the use of more transport equipment. Because of the increased cost of transport equipment, a trade off analysis must also be made between the capacity of the transfer station and the cost of the transport operation including both equipment and labor.

### **Equipment and Accessory Requirements:**

The types and amounts of equipment required, varying with the capacity of the station and its function in the waste management system. Specifically, scales should be provided at all medium and large transfer stations both to monitor the operation and to develop meaningful management and engineering data.

### **Environmental Requirements:**

Most of the large modern transfer stations are enclosed and are constructed of materials that can be maintained and cleaned easily. For direct discharge transfer station with open loading areas, special attention must be given to the problem of blowing papers, wind screens or other the type of station the design and construction should be such that all accessible areas where rubbish or paper can accumulate are eliminated.

### **Factors Affecting the Location of Transfer Station:**

Whenever possible, transfer stations should be located.

- As near as possible, the weighted center of the individual solid waste production areas to be served.
- Within easy access of major arterial highway routes as well as near secondary supplemental means of transportation.
- Where there will be minimum of public and environmental objections to the transfer operations. Where construction and operation will be most economical
- Additional if the transfer station site is to be used for processing operating involving materials recovery and energy production, the requirements for those operations must also be considered.

### **Route Optimization:**

Once equipment and labor requirements are determined collection routes must be laid out so that both the collectors and equipment's are used effectively. In general the layout of collection route involves a series of trails. There is no universal set of routes that can be applied for all the situations. Thus collection vehicle routing (Route optimization) remains today a touristic (common sense, practical) process.

Some heuristic guidelines that should be taken into consideration when laying out routes are as follows.

- i. Existing policies and regulations related to such items as the point of collection and frequency of collection and frequency of collection must be identified.
- ii. Existing system characteristics such as crew size and vehicle type must be co-ordinated.
- iii. Wherever possible route should be laid down so that they begin and end near arterial roads using topographical and physical barriers as route boundaries.
- iv. In hilly areas route should start at the top of the grade and proceed down till as the vehicle is loaded.

- v. Routes should be laid out so that the last container to be collected on the route B located nearest to be disposal site.
- vi. Waste generated at traffic congested location should be collected as early as possible.
- vii. Sources at which extremely large quantities should be serviced during the first part of the day.

**Layout Of Collection Routes/ General Steps Involved:**

- i. Preparation of location maps showing penitent data and informationconcerning waste generation source
- ii. Data analysis and as required, preparation of information summary table.
- iii. Preliminary layout of routes.
- iv. Evaluation of preliminary routes and development of balanced routesby successive trials.

**PROBLEM:**

- 1) Layout collection routes for the residential shown in the accompanyingfigure. Assume the following data that are applicable for laying out collection routes.

**1. General:**

- a) Occupants/ resident = 3.5
- b) Solid waste generation rate = 1.6 Kg/ person/day
- c) Collection frequency =
- d) Type of collection service = curb
- e) Collection crew size = one person
- f) Collection vehicle capacity = 20m<sup>3</sup>

- g) Compacted density of solid waste in collection vehicle = 325 Kg/m<sup>3</sup>

**2. Route Constraints:**

- a) No- U-turns in streets  
b) Collection from each side of street with stand-up-right hand drive collection vehicle.

Solution:

i) Determination of total number of residences from which waste are to be calculated. Total No. of Residences = 332

ii) Determination of compacted volume of solid waste to be collected/week

$$= \frac{332 \times 3.5 \times 1.6 \times 7}{325}$$

$$= \frac{13014.4}{325}$$

$$= 40 \text{ m}^3/\text{week}$$

iii) Determination of number of trips/ week trips/ week = 40 = 2  
20 No's

iv) Determination of average number of residency from which wastes are to be collected each day.

$$\text{Residency/trip} = 332 = \underline{166 \text{ Nos.}}$$

## Garbage Chutes:



Waste usually bagged is placed by tenants in specially designed vertical routes with opening located on each floor. Waste discharge in chutes are collected in large containers, compacted into large containers or baled directly. Chutes for use in apartment buildings are available in diameter 12-36 inch (30-90cm). The most common chute diameter is 34 inch. All the available can be furnished with suitable intake chute either at the bottom at the site or used for installation on various floor levels. Draft baffles at intake doors, door locks, sprinklers, disinfection systems, sound insulations and roof vents are among the many accessories available. Use of disinfecting and

sanitizing unit is recommended because the cleanliness of chute and absence of odor generally depend to a large extent on their use. In designing chutes for high rise buildings one must consider variations in the rate at which solid waste are discharged.

### **Solid waste management 2000 rules with, 2016 amendments.**

The Government has revamped the Municipal Solid Wastes (Management and Handling) Rules 2000 and notified the new Solid Waste Management Rules, 2016 on April 8, 2016. The salient features of the SWM Rules, 2016 are as under;

- Areas Cover: These rules are applicable to;
  - a) Every urban local body (Mega city to Panchayat level),
  - b) Outgrowths in urban agglomerations
  - c) Census towns as declared by the Registrar General and Census Commissioner of India,
  - d) Notified areas, Notified industrial townships,
  - e) Areas under the control of Indian Railways,
  - f) Airports/ airbases,
  - g) Ports and harbors,
  - h) Defense establishments,
  - i) Special economic zones,
  - j) State and Central government organizations,
  - k) Places of pilgrims,
  - l) Religious and historical importance as may be notified by respective State government from time to time and
  - m) Every domestic, institutional, commercial and any other non-residential solid waste generator situated in the areas.

- The Waste Generators
  - a) Every household
  - b) Event organizers
  - c) Street Vendors
  - d) RWAs & Market Associations
  - e) Gated Community having more than area 5000 sq.m
  - f) Hotels & restaurants, etc.
  
- Duties of Waste generators and Authorities:
  - a) Every Waste Generators shall segregate waste and store separately and hand over to Municipal workers or authorized waste pickers
  - b) Ministry of Environment, Forest & Climate Change shall constitute 'Central Monitoring Committee' to monitor and review every year. (iii) MoUD shall frame National Policy on SWM and coordinate with States/UTs, provide technical guidelines, financial support, training to local bodies, etc.
  - c) Departments of Fertilizers & Chemicals shall assist in market development for city compost and make available to companies (3/4 bags compost: 6/7 bags Fertilizers).
  - d) Ministry of Agriculture shall make flexible Fertilizer Control Order, promote utilization of compost, testing facility for compost and issue guidelines.
  - e) Ministry of Power shall fix tariff of power generation from W-T-E project and ensure distribution through companies.
  - f) MNRE shall facilitate infrastructure for waste-to-Energy plants and provide subsidy.
  - g) Secretary- In charge, UD (state/UT) shall prepare State Policy/Strategy, adopt 3-Rs, coordinate for state planning, identification of common/regional landfills, and notify guidelines of buffer zones.
  - h) District Collector/Magistrate shall facilitate identification of landfill site, quarterly review the performance of local bodies. (x) Secretary,

Panchayats: same as Secy. UD at Panchayath level. (xi) CPCB shall coordinate with SPCBs/PCCs for monitoring and Annual Reports, formulation of standards, review new technologies, prepare guidelines for buffer zones restricting from residential, commercial and construction activities areas; and inter-state movement of waste.

- i) Local Authority/Panchayats shall prepare SWM plan with time line and its implementation, segregate, adopt 3-Rs, material recovery, processing/ disposal of Waste, user fee and levy spot fine.
  - j) SPCBs/PCCs shall monitor, issue authorization and regulate
- Criteria for Hilly Region: Avoid landfill, make waste transfer stations, strict action for littering and construct landfill at plain areas.
  - Waste to Energy plant for waste with 1500 Kcal/kg and above for coincineration in cement and power plants.
  - Time Frame for Implementation of SWM Rules:
    - a) Landfill Identification: 1 year Procurement of waste processing facilities: 2 years
    - b) Ensure segregation of waste: 2 years
    - c) Cities up to 1 million populations: 2 Years
    - d) Million plus cities: 3 years
    - e) Setting up sanitary landfills: 3 years
    - f) Bioremediation/capping of old landfills: 5 years
  - Review of implementation of rules at Various levels;
    - a) MoEF&CC, Central Monitoring Committee: Every year
    - b) District Collector review performance of Local authorities: Quarterly

## MODULE - 2

### **Processing Techniques:**

Processing techniques is used in SWM.

- a) To improve the efficiency of solid waste disposal systems.
- b) To recover resources (usable materials).
- c) To prepare materials for the recovery of conversion products and energy.

Process used routinely to improve the efficiency of solid waste systems and to recover materials is.

- a) Mechanical volume reduction (compaction)
- b) Chemical volume reduction (incineration)
- c) Mechanical size reduction (Shredding)
- d) Component separation (Manual or Mechanical)
- e) Drying and Dewatering (Moisture content reduction)

### **Factors That Should Be Considered In Evaluating On Site Processing Techniques:**

<b>FACTORS</b>	<b>EVALUATION</b>
<b>CAPABILITIES</b>	What will the device or Mechanism do? Will it's use be an Improvement over conventional practices?
<b>RELIABILITY</b>	Will the equipment perform it's designated function with little attention beyond preventive maintenance
<b>SERVICE</b>	Will servicing capabilities beyond those of the local building Maintenance staff be required occasionally.

SAFETY OF OPEATIONS	If the proposed equipment reasonably fool proof sothat it may be operated by tenants one buildingpersonnel with Limited mechanical knowledge one abilities.
EASE OF OPERATION	Is the equipment easy to operate by a tenant or by building Personnel
EFFICIENCY	Does the equipment perform efficiently and with a minimum
ENVIRONMENT	Does the equipment pollute or contaminate the environment?
HEALTH	Does the device, Mechanism or equipment create or amplify
HAZARDS	Health hazards?

## Chemical Volume Reduction

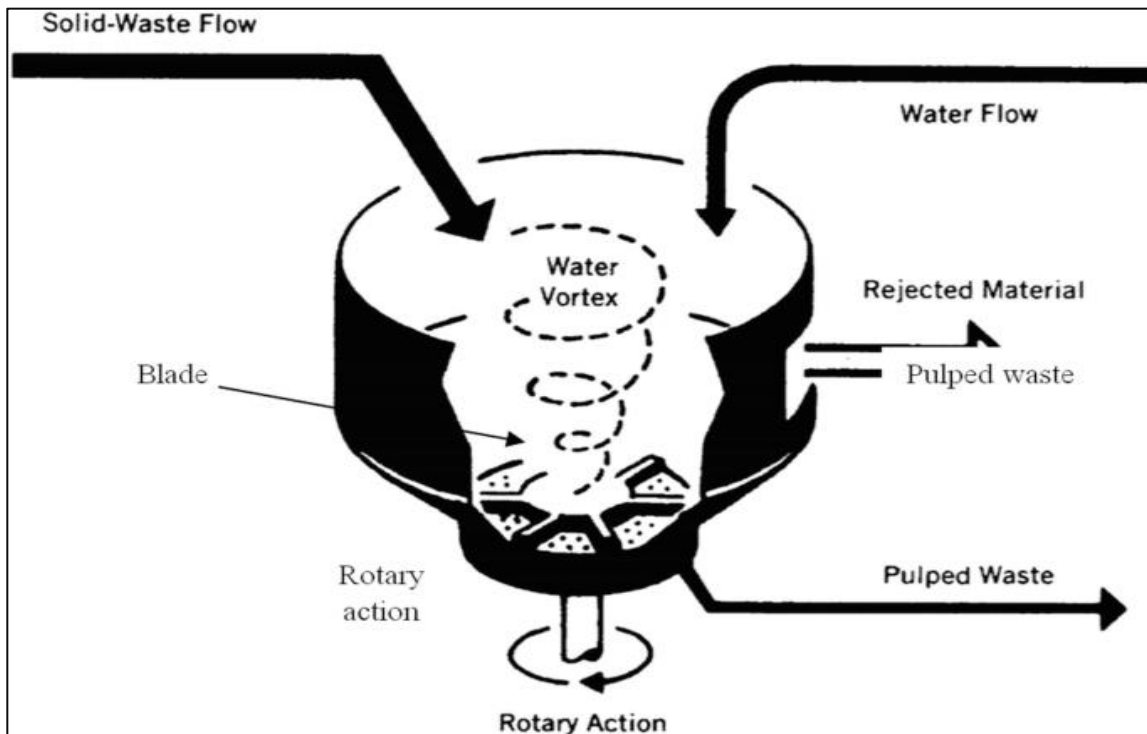

Chemical volume reduction is a method, wherein volume reduction occurs through chemical changes brought within the waste either through an addition

of chemicals or changes in temperature. These other chemical methods used to reduce volume of waste chemically include pyrolysis, hydrolysis and chemical conversions.

## Component Separation

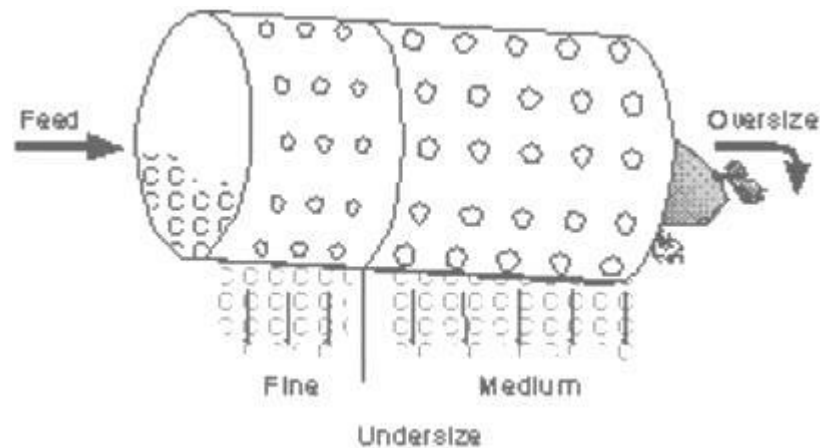

Component separation is a necessary operation in which the waste components are identified and sorted either manually or mechanically to aid further processing.

### Objectives

- Recovery of valuable materials for recycling;
- Preparation of solid wastes by removing certain components prior to incineration, energy recovery, composting and biogas production

### Types of component separation

- Air Separation
- Magnetic Separation
- Screening
- Flootation

## Air Separation



This technique has been in use for a number of years in industrial operations for segregating various components from dry mixture. Air separation is primarily used to separate lighter materials (usually organic) from heavier (usually inorganic) ones. The lighter material may include plastics, paper and paper products and other organic materials. It is done by conveying air streams, which is usually done in a cyclone separator. As you can see in picture above, the shredded waste is introduced to the unit, because of air the lighter component come up and heavy stays at bottom. The two components are than collected separately. The light fraction may be used, with or without further size reduction.

## Magnetic Separation

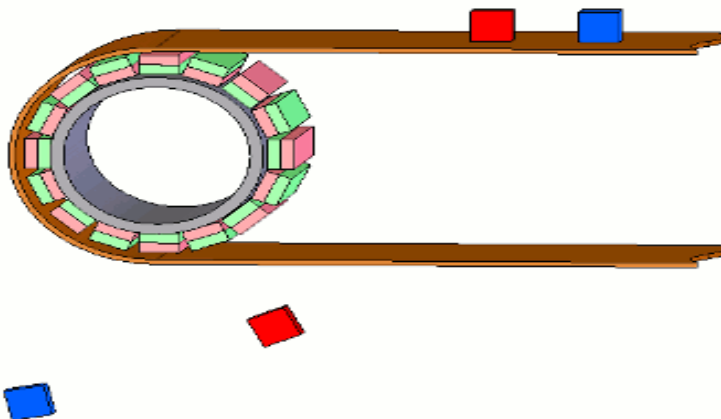

Ferrous materials are usually recovered either after shredding or before air classification. When wastes are mass-fired in incinerators, the magnetic separator is used to remove the ferrous material from the incinerator residue. Magnetic recovery systems have also been used at landfill disposal sites.

### **Suspended magnet:**

A permanent magnet is used to attract the ferrous metal from the waste stream. When the attracted metal reaches the area, where there is no magnetism, it falls away freely. This ferrous metal is then collected in a container. Magnetic pulley: This consists of a drum type device containing permanent magnets or electromagnets over which a conveyor or a similar transfer mechanism carries the waste stream. The conveyor belt conforms to the rounded shape of the magnetic drum and the magnetic force pulls the ferrous material away from the falling stream of solid waste

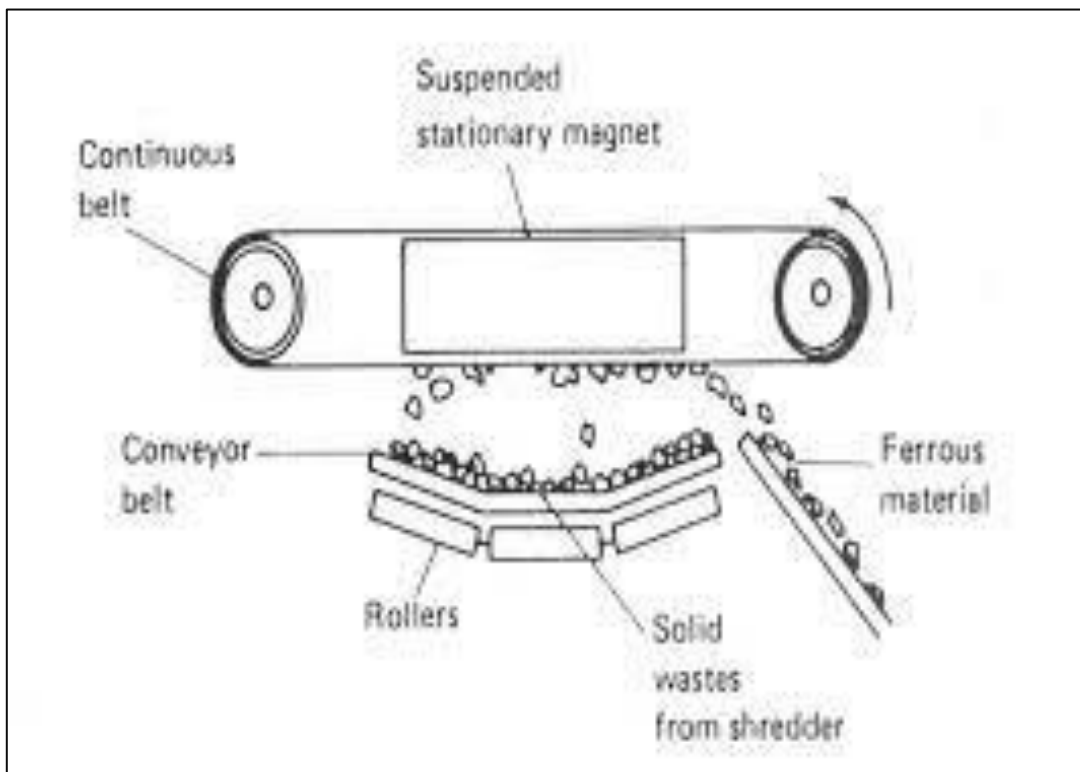

## Screening of Waste

Screening is the most common form of separating solid wastes, depending on their size by the use of one or more screening surfaces. Screening has a number of applications in solid waste resource and energy recovery systems. Screens can be used before or after shredding and after air separation of wastes in various applications dealing with both light and heavy fraction materials. The size of the sieve is decided based on the waste size required for treatment.

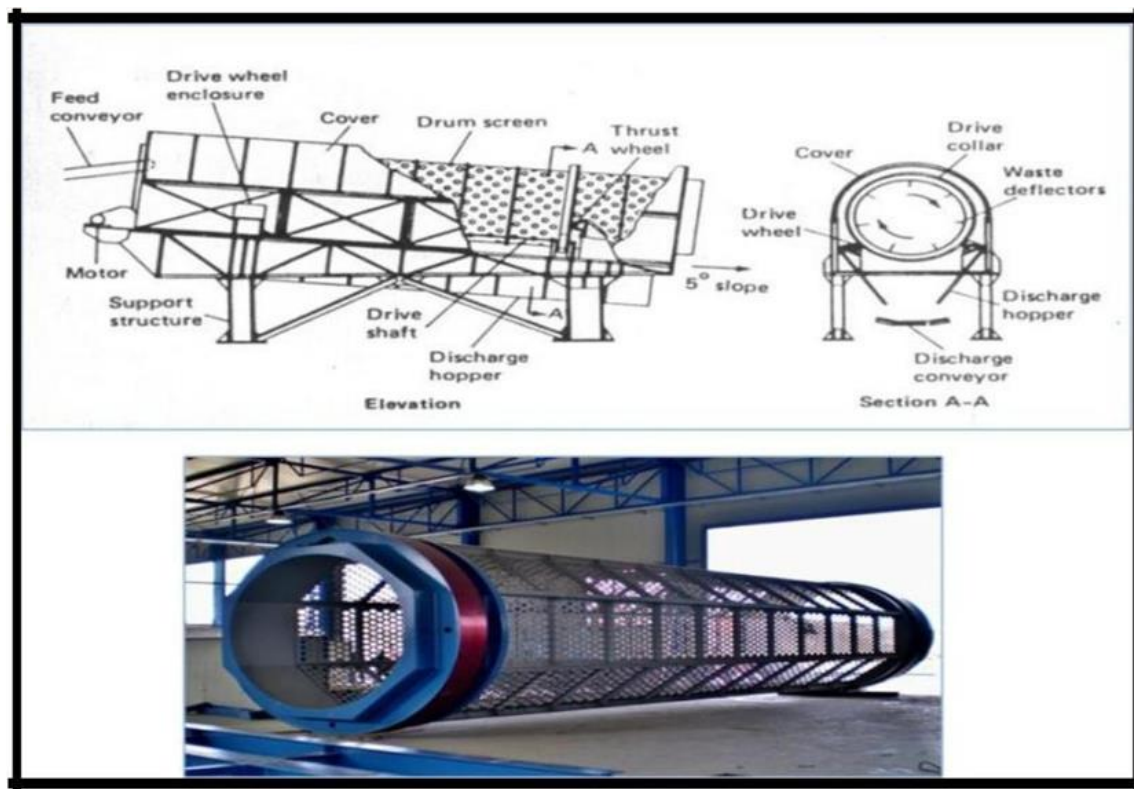

The most commonly used screens are rotary drum screens and vibrating screens.

Rotating wire screens with relatively large openings are used for separation of cardboard and paper products, vibrating screens and rotating drum screens are typically used for the removal of glass and related materials from the shredded solid wastes. The vibration of screens further fastens the process of screening.

## Separation Techniques

Hand-sorting or previewing: Previewing of the waste stream and manual removal of large sized materials is necessary, prior to most types of separation or size reduction techniques. This is done to prevent damage or stoppage of equipment such as shredders or screens, due to items such as rugs, pillows, mattresses, large metallic or plastic objects, wood or other construction materials, paint cans, etc.

Inertial separation: Inertial methods rely on ballistic or gravity separation principles to separate shredded solid wastes into light (i.e., organic) and heavy.

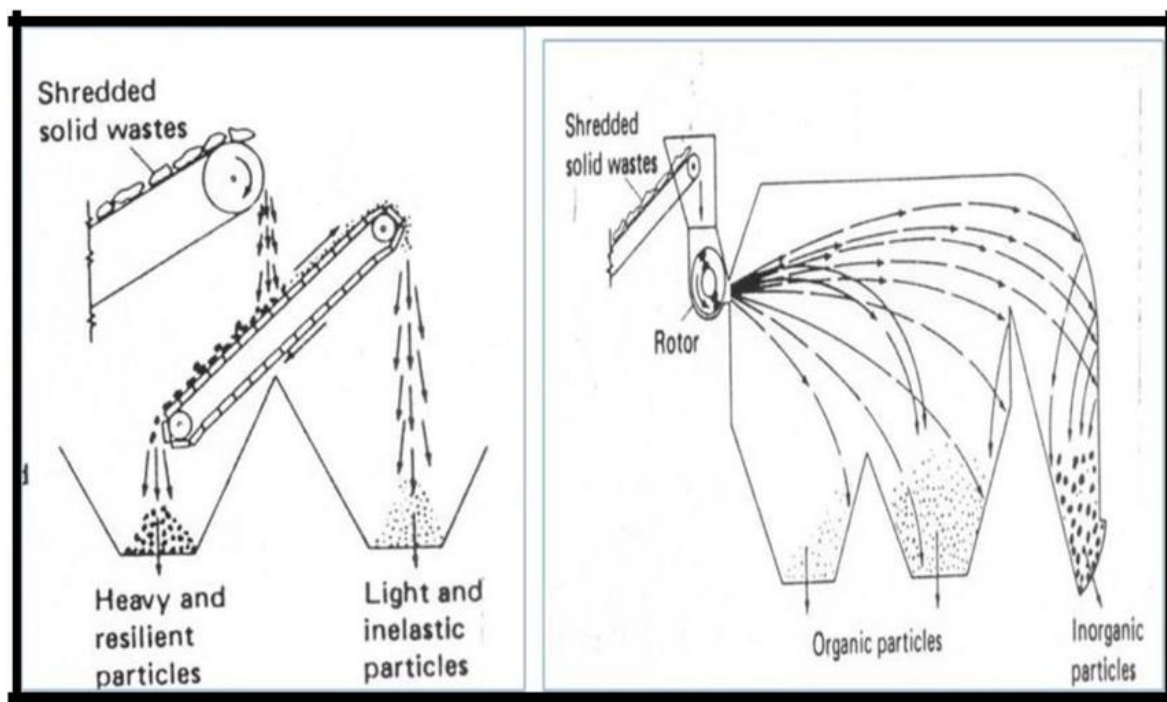

### Separation by Flotation:

In the flotation process, glass-rich feedstock, which is produced by screening the heavy fraction of the air-classified wastes after ferrous metal separation, is immersed in water in a soluble tank. Heavy material settles and lighter are removed from floatables

Optical sorting: Optical sorting is used mostly to separate glass from the waste stream, and this can be accomplished by identification of the transparent properties of glass to sort it from opaque materials (e.g., stones, ceramics, bottle caps, corks, etc.) in the waste stream. Optical sorting involves a

compressed air blast that removes or separates the glasses – plain or colored. Drying and Dewatering Drying and dewatering operations are used primarily for incineration systems, with or without energy recovery systems. These are also used for drying of sludge in wastewater treatment plants, prior to their incineration or transport to land disposal. The purpose of drying and dewatering operation is to remove moisture from wastes and thereby make it a better fuel.

Sometimes, the light fraction is palletized after drying to make the fuel easier to transport and store, prior to use in an incinerator or energy recovery facility.

- Convection drying: In this method, hot air is in direct contact with the wet solid waste stream
- Conduction drying: In this method, the wet solid waste stream is in contact with a heated surface
- Radiation drying: In this method, heat is transmitted directly to the wet solid waste stream by radiation from the heated body.

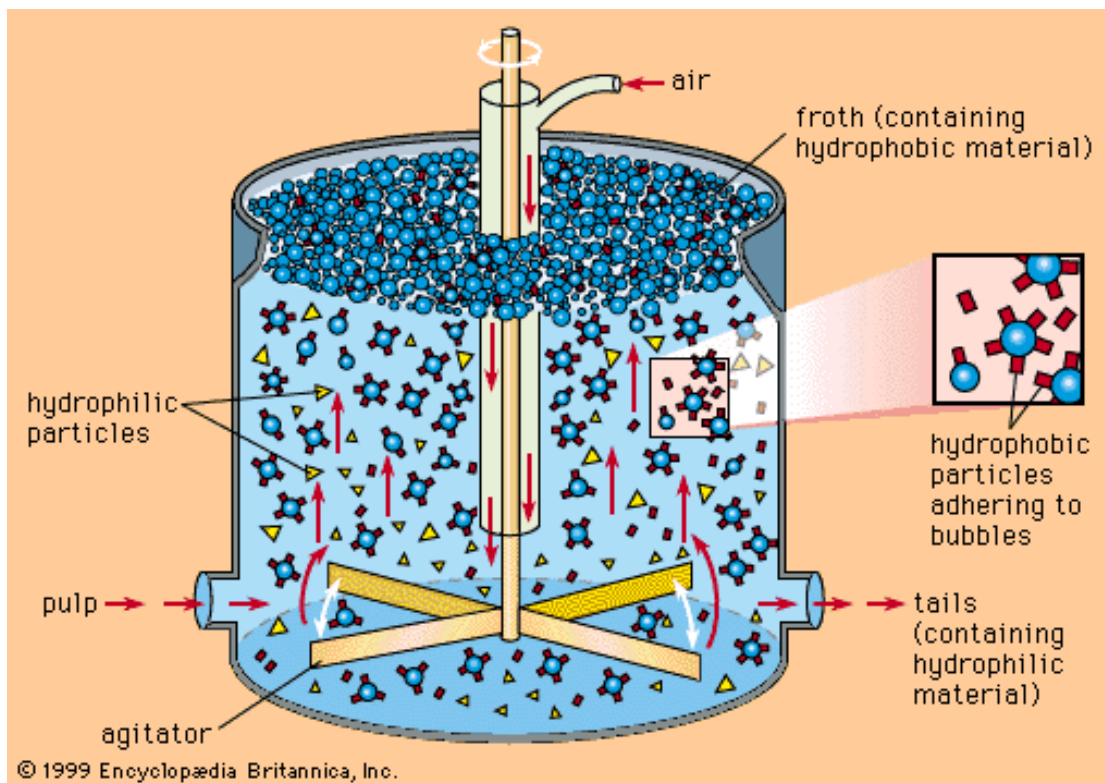

## **3T process**

The process of combustion is complex in nature and multiple parameters affect the combustion efficiency. Out of these several parameters, time, turbulence and temperature are referred to as 3 Ts of combustion. It is very important to control and optimize these 3 Ts to get maximum out of the combustion process.

### **I. Time**

When a fuel is being burned, it is important that sufficient time is available so that the fuel burns completely. 100% combustion means that the fuel is fully oxidized and full oxidation of the carbon, hydrogen and other combustible elements has taken place. If fuel remains in the combustion zone for a time lesser than necessary, it will be partially burned which increases the un-burnt losses. On the other hand, if it remains for a time higher than the required, the power output of the boiler will drop as new fuel will not be able to come in and get burned. Ideally, the fuel should stay for a time sufficient for the complete combustion and then replaced by the fresh fuel. Thus, the time plays a very important role in determining the combustion efficiency.

### **II. Turbulence**

Oxygen makes an essential part of the process of combustion. While burning the fuel, it is essential that it is broken down in small particles. This increases the surface area of the fuel and ensures that sufficient air i.e. oxygen is made available. Turbulence ensures a thorough mixing of the air and the fuel. If turbulence is not maintained, certain part of the fuel will have excess oxygen available for the combustion while the remaining having too little. This will result in incomplete combustion of carbon forming carbon monoxide instead of CO<sub>2</sub>.

### **III. Temperature**

During the combustion, if the temperature is not sufficiently high, fuel will take some time to ignite thus increasing the time of the combustion. This will affect the heat output. Hence, it is very important to maintain correct temperature which ensures that fuel is quickly burnt releasing the complete energy.

# **Principal Components in the Design of Municipal Incinerators,**

## **Air Pollution Control**

Typical waste-incineration facility schematic.

- Waste storage and feed preparation.
- Combustion in a furnace, producing hot gases and a bottom ash residue for disposal.
- Gas temperature reduction, frequently involving heat recovery via steam generation.
- Treatment of the cooled gas to remove air pollutants, and disposal of residuals from this treatment process.
- Dispersion of the treated gas to the atmosphere through an induced-draft fan and stack. There are many variations to the incineration process, but these unit operations are common to most facilities.
- This chapter addresses the combustion and air-pollution control operations commonly used in municipal solid-waste, hazardous-waste, and medical-waste incineration facilities.
- The intent is to identify, and briefly discuss, the design features and operating parameters that have the greatest influence on emissions.
- Waste storage, feed preparation, and gas temperature reduction (which may involve heat-recovery operations) are addressed to a lesser extent.
- This chapter also addresses the air pollutants emitted from incineration processes that are of primary concern from a health effects standpoint .

## **Waste Storage, Feed Preparation and Feeding**

Common waste storage, waste staging, feed preparation and feeding practices for municipal solid-waste, hazardous-waste, and medical-waste incinerators. These practices are highly waste- and facility-specific. Common Waste Storage, Feed Preparation, and Feeding Practices in Municipal Solid-Waste, Hazardous-Waste, and Medical-Waste Incineration Facilities.

Proper design and operation of these “front-end” plant operations are important for several reasons:

- While the plant is operating, the potential for worker exposure to hazardous materials is the greatest in this part of the facility. Without appropriate engineered and administrative controls, including personnel protective equipment, operators can be exposed to hazardous dust and vapors.
- This part of the plant is the highest potential source of fugitive dust and vapor emissions to the environment, and the greatest potential fire hazard.
- Without proper waste preparation and feeding, the furnace combustion performance may be impaired.

There are many regulations and guidelines for the design and operation of waste storage, handling, and feeding systems. Organizations that develop such regulations and guidelines include the U.S. Occupational Safety and Health Administration (OSHA), U.S. Environmental Protection Agency (EPA), and National Fire Protection Association (NFPA).

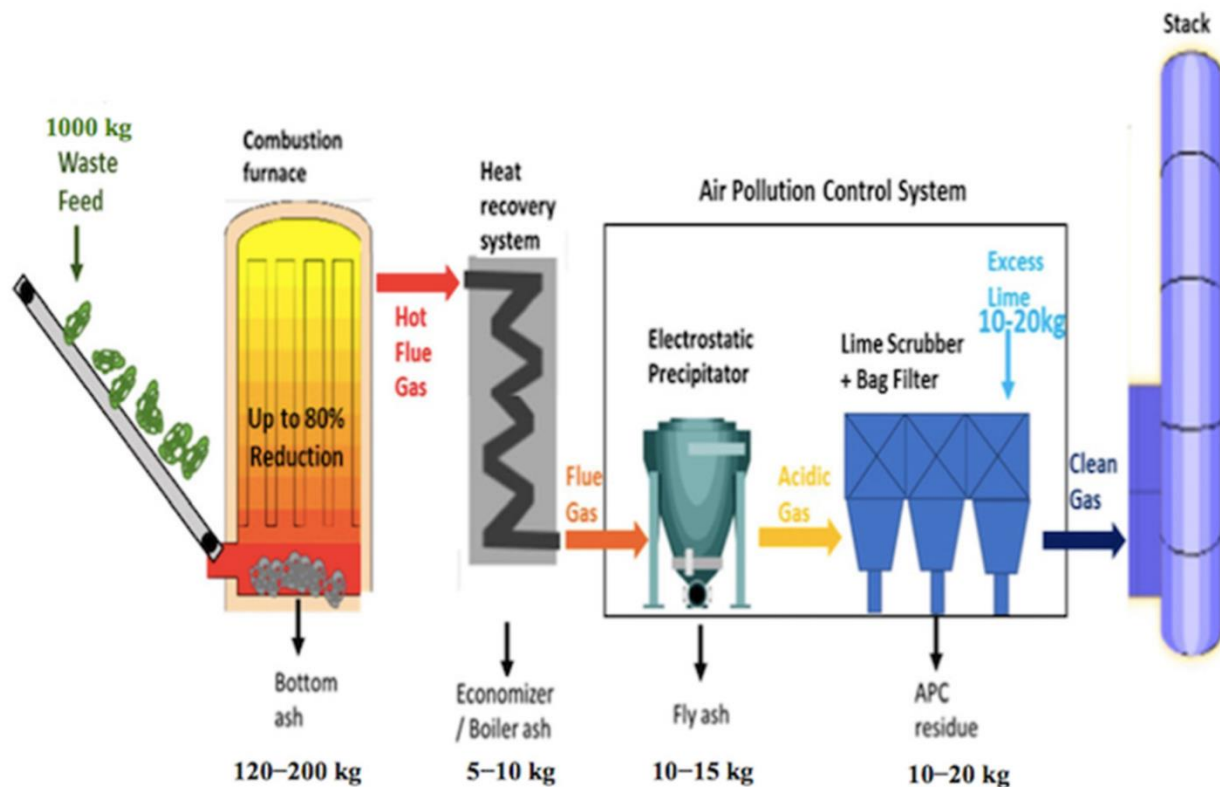

## **Combustion Processes**

### **General Considerations**

Combustion is a rapid, exothermic reaction between a fuel and oxygen (O<sub>2</sub>). In incineration applications, the fuel is predominately waste (although fossil fuels may be co-fired) and the oxygen source is air. Combustion produces many of the same stable end products, whether the material burned is natural gas, coal, wood, gasoline, municipal solid waste, hazardous waste, or medical waste. The flame zone of a well-designed incinerator is sufficiently hot to break down all organic and many inorganic molecules, allowing reactions between most volatile components of the waste and the oxygen and nitrogen (N<sub>2</sub>) in air. The predominant reactions are between carbon (C) and oxygen, producing carbon dioxide (CO<sub>2</sub>), and between hydrogen and oxygen, producing water vapor (H<sub>2</sub>O). Incomplete combustion of organic compounds in the waste feed stream produces some carbon monoxide (CO) and carbon-containing particles. Hydrogen also reacts with organically-bound chlorine to produce hydrogen chloride (HCl). In addition, many other reactions occur, producing sulfur oxides (SO<sub>x</sub>) from sulfur compounds, nitrogen oxides (NO<sub>x</sub>) from nitrogen compounds (and, a little, from the nitrogen in the air), metal oxides from compounds of some metals, and metal vapors from compounds of others.

- The furnace is designed to produce good mixing of the combustion air and the gases and vapors coming from the burning waste. Nevertheless, in parts of the furnace where combustion is not complete (for example, near the walls of the furnace), combustible components of organic compounds are burned off, leaving the incombustible particulate matter known as fly ash entrained in the flue gas. The incombustible portion of the waste (known as bottom ash) is left behind.
- Incineration facilities incorporate a number of general methods for ensuring proper combustion and reducing emissions. A steady situation with no major fluctuations in the waste-feed supply rate, combustion-air flows, or other incineration conditions promotes efficient combustion.
- Inefficient combustion can result in higher levels of products of incomplete combustion. Similarly, the more often a facility is started up and shut down (for maintenance or because of inadequate or varying waste stream volume), the

more uneven the combustion and the greater the potential for increased emissions.

- Optimal design and operation of a furnace requires attention to incineration temperature, turbulence of the gas mixture being combusted, and gas-residence time at the incineration temperature.
- To achieve efficient combustion, every part of the gas stream must reach an adequately high temperature for a sufficient period of time, and there must be adequate mixture of fuel and oxygen.
- The temperature achieved is the result of heat released by the oxidation process, and has to be maintained high enough to ensure that combustion goes to completion, but not so high as to damage equipment or generate excessive nitrogen oxides.
- Typically, temperatures are controlled by limiting the amount of material charged to the furnace to ensure that the heat-release rate is in the desired range, and then tempering the resulting conditions by varying the amount of excess air.
- Turbulence is needed to provide adequate contact between the combustible gases and oxygen across the combustion chamber (macro scale mixing) and at the molecular level (micro scale mixing).
- Proper operation is indicated when there is sufficient oxygen present in the furnace, and the gases are highly mixed. Cool spots can occur next to the furnace's walls; where heat is first extracted from the combustion process. Such cool spots on walls are more substantial in water wall furnaces than in refractory-lined furnaces.
- A number of new design features and operating techniques have been adopted to increase temperature, extend residence time, and increase turbulence in waste incinerators in order to improve combustion efficiency and provide other benefits like improved ash quality.

## **Furnace Types**

Furnaces used for municipal solid-waste, hazardous-waste, and medical-waste incineration. Municipal solid-waste furnace designs have evolved over the years from simple batch-fed, stationary refractory hearth designs to continuous feed, reciprocating (or other moving, air-cooled) grate designs with water wall furnaces for energy recovery. The newer municipal solid-waste incinerators are waste-to-

energy plants that produce steam for electric power generation. Furnace Designs for Municipal Solid-Waste, Hazardous-Waste, and Medical-Waste Incineration. The predominant hazardous-waste incinerator designs are liquid-injection furnaces and rotary kilns. Hazardous wastes are also burned in cement kilns, light-weight aggregate kilns, industrial boilers, halogen-acid recovery furnaces, and sulfuric-acid regeneration furnaces. Medical wastes are burned in fixed-hearth incinerators, with the primary chamber operated in the starved-air mode (newer “controlled air” designs) or excess air mode (older Incinerator Institute of America (IIA) design). Both designs incorporate secondary, afterburner chambers. The smallest medical-waste incinerators are single-chamber, batch-operated devices.

## Furnace Design Considerations for Municipal-Waste Incinerators

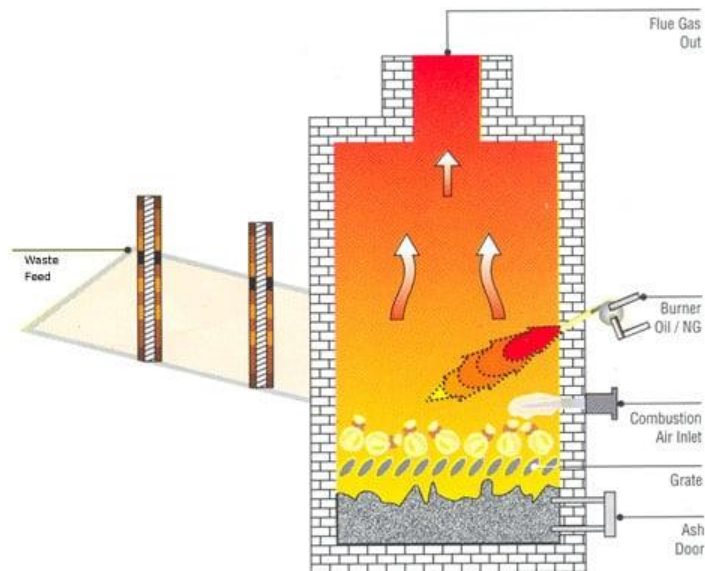

The design of the furnace is critical to optimal combustion. Furnace configurations depend on what they were designed to burn. Older designs, many of which are still used, do not generally permit as efficient combustion as newer designs.

### Sizing

Poor combustor design can prevent stable, optimal combustion conditions. Sizing a furnace to match the quantity of waste fed to the incinerator is important with

respect to temperature, turbulence, and time. If the heat input from the waste is too low for the furnace size, the temperature in the furnace may drop to such an extent that complete combustion is not achieved, particularly in water wall furnaces. If the furnace is too small for the quantity of waste fed, the temperature will be high and there may be difficulty in supplying sufficient oxygen for complete combustion, and the quantities of unburnt residues might be increased.

## **Grates**

In older incinerator systems, traveling grates simply transported refuse into the combustion zone. Newer grate systems are designed to agitate the waste in various ways, causing it to be broken into smaller pieces as combustion proceeds. This process permits exposure of a larger surface area of waste to air and high temperatures, assisting complete combustion by preventing unburnt material from simply being transported through on the grate.

## **Air-Injection Systems**

For complete combustion to occur, air must be injected into the furnace in at least two locations: under the grate that carries burning waste (primary or under fire air) and above the grate to mix additional oxygen with the combustion gases (secondary or over-fire air). Additional controls have been provided in modern municipal solid-waste incinerators to better regulate both the under-fire air at various points on the grate, depending upon burning conditions, and the over-fire air in response to temperature and heat transfer taking place in the furnace. In such advanced systems, primary air is injected into the drying, burning, and burnout zones of the grate, with a separate system for secondary air. Control may be effected by manual or automatic adjustments to dampers. The latter method is preferred, because it allows for automatic control loops with continuous monitoring devices. The temperature and oxygen needs of the furnace can be controlled by adjusting the quantity of primary and secondary air entering the furnace. In plants built before the middle 1980s, particularly those with holes in the furnace walls, the entry of primary and secondary air is not as well controlled, and the excess-air rates required for adequate combustion can be several times the amount that would be required with a more modern design. This can result in

larger volumes of flue gas to be treated for contaminant removal, and reduced efficiency of utilization of the exhaust heat.

### **Arches and Bull Noses**

To achieve complete combustion, gases produced must remain in the high-temperature zone of the furnace for a minimal residence time, usually 1-2 seconds. Achieving that residence time is usually accomplished by designing the furnace to retard the upward flow of gases, for example, by installing irregularities into the furnace walls. Modern facilities are configured to achieve improved combustion efficiency by using arches and bull noses. Arches, which are structures above the burning and burnout zones, are used to prolong the stay of combustion gases above the grate area. Bull noses are protrusions that are built into the furnace walls, usually near the point of injection of over-fire air, to upset the normal upward flow of the heated gases. Volatilizing from the burning waste. The induced gas redirection retards the movement of the combustion gases out of the furnace and promotes mixing with air.

### **Flue-Gas Recirculation**

Flue-gas recirculation systems are used to recycle into the furnace relatively cool flue gas (extracted after the heat exchangers have reduced its temperature) that contains combustion products and an oxygen concentration lower than air. The process is used to lower nitrogen oxide formation by limiting the flame temperature and by slightly diluting the flame oxygen concentration. Care must be taken to ensure that not too much flue gas is recirculate, lest the combustion process be adversely affected.

### **Auxiliary Burners**

Waste feedstock, particularly municipal solid waste, is heterogeneous, and its components, or even the whole waste stream, may vary in combustibility. That can make it difficult to maintain the minimal temperature necessary throughout a furnace. In modern combustors, maintenance of temperature can be aided by auxiliary burners that are typically set to come on automatically when the furnace temperature falls below a predetermined point; the threshold is usually set between

1,500 and 1,800°F at the location of the auxiliary burner, which is close to the chamber exit. The auxiliary burners are fed fossil fuels and are particularly intended to be used during system startup, shutdown, and upsets.

### **Gas-Temperature Reduction Techniques**

The most common combustion-gas cooling techniques for incinerators are waste-heat boilers, and direct-contact water-spray quenches. Waste-heat boilers are employed on all new municipal solid waste-to-energy plants, many hazardous-waste incinerators, and some of the larger medical-waste incinerators. Waste-to-energy plants has radiant water wall furnaces as well as convective boiler sections. Hazardous-waste and medical-waste incinerators usually have just convective boiler sections, typically of fire-tube rather than water-tube design. Most hazardous-waste and medical-waste incinerators, particularly the smaller units, do not have heat-recovery boilers. Combustion gases are quenched by water sprays atomized into the hot gas flow. Other, less common, gas-temperature reduction methods include air-to-gas heat exchangers and direct gas tempering with air. Gas cooling techniques are integral to incineration system design, and can be important with respect to emissions of certain pollutants. As discussed later in this chapter, emissions of mercury and dioxins and furans can be affected by the rate of gas cooling and the air pollution control device (APCD) operating temperature. Dry APCDs, including scrubbers and particulate control devices, achieve the highest degree of reduction of mercury, dioxins and furans, and acid gases when flue-gas temperatures are lowered to about 300°F or less at the APCD inlet.

### **Air-Pollution Control Techniques**

- Historically, incinerator APCDs were designed to remove two classes of pollutants which are particulate matter and acid gases. More recently, some method for improving the removal of dioxins and/or mercury is considered necessary.
- Also, as discussed in, NO<sub>x</sub> emission limits have been established for some incinerators.
- In several instances in European plants, increasingly stringent regulations have resulted in use of more than one particulate-control device or more than one

type of scrubber in a given incineration facility, and emissions have typically been reduced more than would be expected with the single device alone.

- Modern municipal solid-waste incinerators in the United States are equipped for particulate, acid gas, and, in many cases, dioxin and mercury removal.
- These municipal solid-waste incinerators typically employ fabric filters or dry electrostatic precipitators (ESP) for particulate removal. ESPs became common in the 1970s. In the 1980s, fabric filters, also known as bag houses, started to replace, or be used in tandem with, ESPs as the preferred design for particulate removal because of their improved capacity for filtering finer particles.
- Spray dryer absorbers and dry-lime injection systems are used for acid gas—HCl and sulfur dioxide (SO<sub>2</sub>)—removal. Dry powdered activated carbon injection systems provide dioxin and furan and mercury removal.
- Many small old municipal-waste incinerators do not have effective air-pollution control systems.
- Some have only a particulate-control device, often a relatively ineffective one designed to meet old standards for emissions of particulate. Newer ones have both particle and acid-gas-control devices, such as wet scrubbers.
- Hazardous-waste incinerators in the United States have traditionally used wet air-pollution control systems. Recently, however, there has been a trend toward fabric-filter systems (particularly in larger incineration facilities) because of their superior fine-particle-emission and metal-emission control efficiencies and their ability to produce a dry residue rather than a scrubber wastewater stream.
- Wet ESP devices may be favored in the future for existing wet APCDs to meet emission-control regulations.

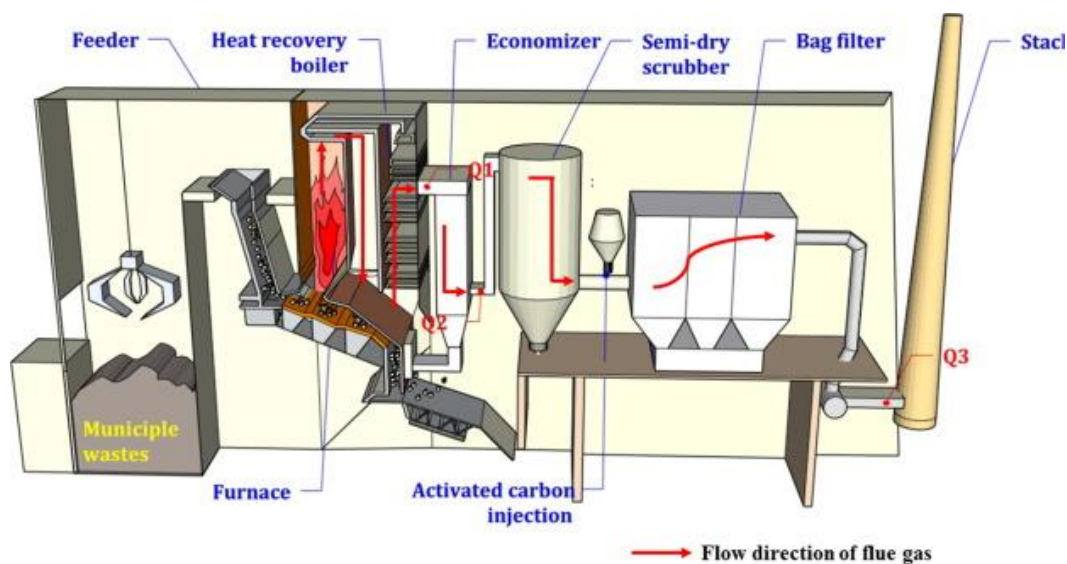

## Particulate Collectors

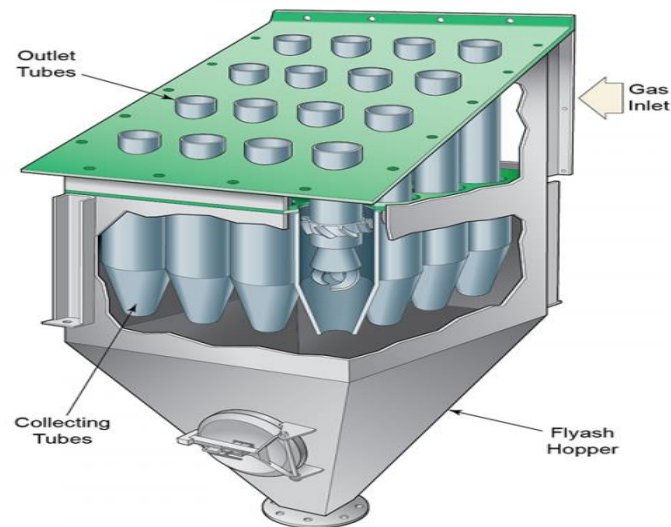

- Fine-particle control devices fall into three general categories, which are filtration collectors, including fabric filters (bag houses); electrostatic collectors, including dry and wet electrostatic precipitators (ESPs) and ionizing wet scrubbers; and wet inertial-impaction collectors, including venturi scrubbers and advanced designs that use flux-force condensation-enhancement techniques.
- When properly designed and operated, all of them are capable of effective fine-particle control, but they are not all equally effective. Fabric filters are used at relatively low flue- gas temperatures (about 280-400°F).
- Flue gas containing particles passes through suspended filter bags. The particles suspended in the gas streams are collected on the filters and periodically removed and fed to a collection hopper.
- Fabric filters are widely used today in municipal solid-waste incineration facilities, cement kilns, and lightweight-aggregate kilns because of their highly efficient collection of fine particles.
- They are used in a smaller number of hazardous-waste incinerators and medical-waste applications. They are limited to an operating temperature range between the gas dew point on the lower end and the bag- material thermal-stability limit on the upper end.
- A typical and practical operating-temperature for this technology in municipal solid-waste applications is about 300°F, but the best environmental

performance is achieved at lower temperatures (to minimize dioxin and furan production within the APCD itself).

- The primary factors affecting the performance of fabric filters are fabric type and weave, air-to-cloth ratio (gas flow rate to total bag surface area), cleaning method and frequency, bag cake formation and maintenance, and bag integrity with respect to mechanical, thermal, and chemical breakdown.
- The fabric type must be matched to the temperature range of the application and the chemical composition of the gas for good performance and bag longevity. Maximal air-to-cloth ratio for good performance is also a function of fabric type and weave.
- The method, intensity, duration, and frequency of the bag-cleaning cycles are important to maintain mechanical integrity of the bags and good cake formation.
- Good cake formation (as measured by bag house pressure differential) is required for good performance of woven and felted bags; it is less critical for laminated membrane bags, which can function using surface filtration alone.
- In properly designed and operated fabric-filter systems, maintaining bag integrity is the critical determinant of day-to-day performance. Bag integrity can be monitored via pressure drop, visual stack-opacity inspections, continuous online stack-opacity monitors, or other continuous monitoring techniques that use optical sensing or turboelectric sensing.
- During shutdowns, bag integrity can be checked by visual examination of the clean-gas plenum for localized dust buildup.
- More-sensitive techniques involve the use of fluorescent sub micrometer powder and black-light examination of the plenum.
- Dry ESPs are widely used today in municipal solid-waste incineration facilities and on cement kilns and coal-fired boilers that burn hazardous waste.
- Dry ESPs are less effective than fabric filters for collection of sub micrometer particulate matter (0.1-1.0  $\mu\text{m}$ ) but are nevertheless very effective collection devices.
- Their performance is influenced by a variety of design characteristics and operating conditions, including the number of electric fields used, charged electrode wire (or rod) and grounded collection plate (or cylinder) geometry, specific collection area (ratio of collection surface area to gas flow rate),

electrode design, operating voltage and current, spark rate, collector cleaning method (to limit buildup or re-entrainment of dust), fluctuations in gas flow rate and temperature, particulate-loading fluctuations, particle-size distribution, and particle resistivity (less important for wet ESPs).

- Wet ESPs have superior submicron particle collection capabilities because they do not suffer rapping re-entrainment and dust layer back-corona problems associated with dry ESPs.
- In a properly designed unit, the important monitoring and process-control measures are inlet gas temperature (dry ESPs only), gas flow rate, electrical conditions (voltage, current, and spark rate), cleaning intensity and frequency, and hopper ash level (dry ESPs only).
- Wet inertial-impaction scrubbers, primarily venture scrubbers, have historically been the particulate matter control technology of choice for most hazardous-waste and medical-waste incinerators.
- They are inherently less efficient for sub micrometer particulate matter than fabric filters or ESPs, but nonetheless can meet regulatory requirements in many applications.
- The primary performance criterion for most wet inertial-impaction scrubbers is the gas-pressure drop, a measure of the energy applied to atomize scrubbing liquid and create fine droplets for particle impaction. For injector venture scrubbers.

### **Acid Gas Scrubbers**

- A commonly used APCD for removal of acid gases is a packed-bed absorber. A scrubbing liquid is trickled through a matrix of random or structured packing through which the gas is simultaneously passed, resulting in gas-liquid contact over a relatively large surface area.
- The scrubbing liquid can be water or an alkaline solution, which reacts with the acid-gas constituents to form neutral salts.
- The wastewater discharge from the packed-bed absorber is a salt-water brine that must be managed properly.
- This effluent may contain untreated acids, trace organics, metals, and other solids removed from the gas stream.

- Packed bed absorbers have been used for decades in the United States, primarily in hazardous-waste and medical-waste incineration applications.
- They have been used in Europe for municipal solid-waste applications.
- The European installations include dual-stage wet absorbers, in which the first stage is operated with an acidic scrubber liquid and the second stage is operated with an alkaline scrubber liquid.
- Acid gases, such as HCl, that are highly water soluble are largely collected in the first stage. Acid gases, such as SO<sub>2</sub>, that are not very water soluble are effectively collected in the second, alkaline stage.
- The important design and operating criteria for wet acid-gas absorbers are gas velocity, liquid-to-gas ratio, packing mass transfer characteristics, pH of the scrubbing liquid, and materials of construction (to prevent corrosion).
- In recent years, municipal solid-waste and a few larger hazardous-waste and medical-waste incineration facilities have used spray-dryer scrubbers for acid-gas control.
- The spray dryers use slurries of lime, sodium carbonate, or sodium bicarbonate as the alkaline reagent.
- The water in the atomized slurry droplets evaporates, cooling the gas, and the alkali particles react with the acid-gas constituents to form dry salts.
- The salts and untreated alkali must be captured in a downstream fabric filter or electrostatic precipitator.

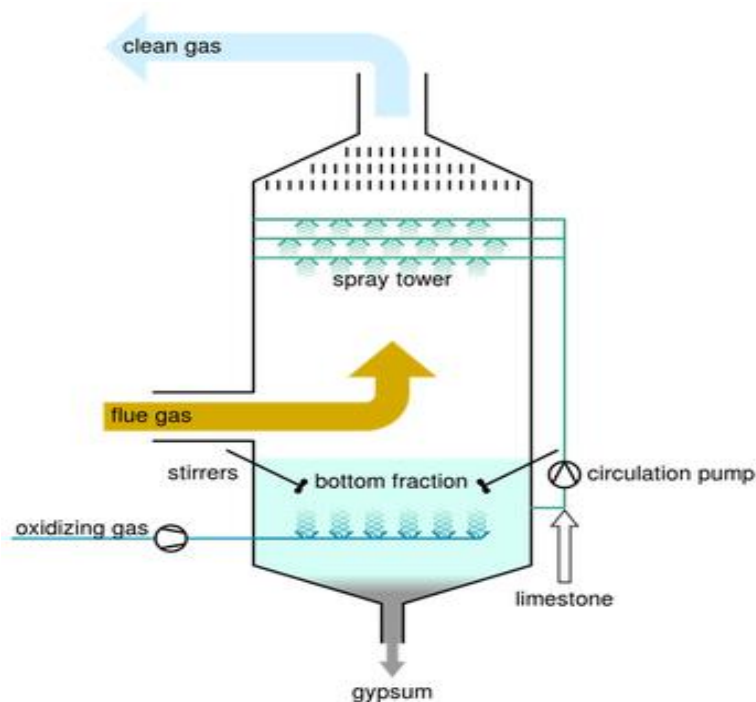

## NO<sub>x</sub> Controls

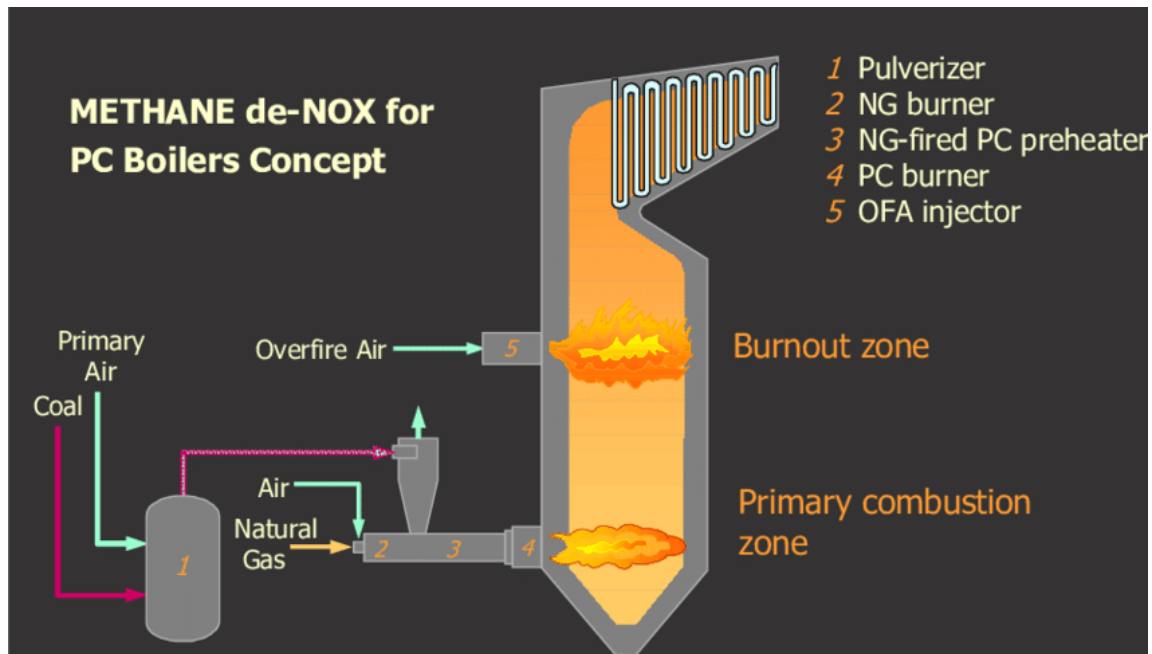

- NO<sub>x</sub> emissions can be reduced by combustion-furnace designs, combustion-process modifications, or add-on controls.
- Combustion-furnace designs that reduce thermal NO<sub>x</sub> include a variety of grate and furnace designs, bubbling and circulating fluidized-bed boilers, and boiler designs, especially those with automatic controls, that permit flue-gas recirculation.
- Combustion-process modifications that reduce NO<sub>x</sub> formation include controlling the amount of oxygen available during the combustion process, and operating within a specific temperature range.
- For minimizing NO<sub>x</sub> production in the combustion process, it is recommended that there be a lower-oxygen condition just above the grates (or in the primary chamber of a dual-chamber facility) coupled with a higher excess-oxygen condition at the location of over fire air injection (or in the secondary chamber of a dual-chamber facility).
- Municipal solid-waste incineration facilities tend to create the most NO<sub>x</sub> when furnace temperatures are higher than is necessary (higher than 2,000°F) to destroy products of incomplete combustion (PICs).

- To minimize NO<sub>x</sub> formation, and the formation of PICs, the furnace should be operated within fairly narrow ranges of temperature and excess oxygen (9-12%) with turbulent (well-mixed) conditions.
- Some NO<sub>x</sub> formation is inevitable from nitrogen present in the fuel and from atmospheric nitrogen, and it may be necessary to use flue-gas controls to achieve further reduction of these emissions.
- Add-on NO<sub>x</sub> flue-gas control systems include selective non catalytic reduction (SNCR), selective catalytic reduction (SCR), and wet flue-gas de nitrification.
- SNCR reduces NO<sub>x</sub> by injecting ammonia or urea into the furnace via jets positioned at the location where temperatures are about 1600-1800°F.
- In the proper temperature range, the injected ammonia or urea combines with nitrogen oxide to form water vapor and elemental nitrogen. SCR operates at a lower flue gas temperature than SNCR, and in addition uses a catalyst.
- Ammonia is injected into the flue gases when they are at about 600°F, and the mixture is passed through a catalyst bed.
- The catalyst bed may be shaped in a variety of forms (honeycomb plates, parallel ridged plates, rings, tubes, and pellets), while the catalyst can be one of a variety of base metals (such as copper, iron, chromium, nickel, molybdenum, cobalt, or vanadium).
- Each combination has advantages and disadvantages with respect to catalyst-to-NO<sub>x</sub> contact, fouling of the catalyst, and pressure drop through the catalyst.
- The biggest disadvantage of SCR for incineration applications is that the combustion gas must always be reheated to the required 600°F temperature range after cooling below this level to remove particulate matter.
- The catalyst beds required for SCR must be installed downstream of highly effective particulate removal devices to avoid fouling.
- Wet scrubbers for NO<sub>x</sub> removal are comparable to wet acid gas absorbers in configuration. They use strong oxidizers in aqueous solution to convert NO to NO<sub>2</sub> (which is water soluble in caustic solution) or NO<sub>3</sub><sup>-</sup> (nitrate), which is water-soluble. The exact chemistries of these systems are considered proprietary by the vendors.

## **Carbon Adsorption and Other Dioxin and Mercury Removal Techniques**

- Carbon injection refers to the injection of finely divided activated carbon particles into the flue gas stream ahead of the particulate APCD.
- The carbon particles adsorb pollutants on their surface, and then the carbon particles are themselves captured in the particulate APCD.
- Activated carbon has a large surface-area-to-volume ratio, and is extremely effective at adsorbing a wide range of vapor-phase organic-carbon compounds, and also some other vapors (like mercury) that are otherwise hard to control.
- Maximum effective use of the technique requires optimization of the rate of injection of activated carbon (Brown and Felsvang 1991).
- Studies in Europe and practical experience in the United States and elsewhere indicate that this technique can substantially reduce emission of dioxins and furans and of mercury.
- Also, Lerner (1993) reported that cadmium chloride is effectively removed from a flue gas stream by using activated carbon. Dioxins and furans are removed along with mercury by injection of powdered activated carbon in a number of municipal-waste incinerators and a few hazardous-waste incinerators.
- This is a widely used form of emissions control in the United States and is quite effective for PCDD/PCDF removal.
- Removal efficiency is a complex function of carbon type, dosage, gas temperature, and gas-to-solid contact efficiency.
- Other add-on control technologies used outside the United States are adsorption in granular activated carbon or coke beds, catalytic oxidation in SCR units (which are also the most efficient NO<sub>x</sub> controls demonstrated commercially), and injection of an inhibitor of dioxin-formation catalyst.
- For high efficiency mercury removal, many municipal solid-waste incinerators and a smaller number of hazardous-waste and medical-waste incinerators have adopted powdered activated carbon injection upstream of dry particle collection devices, usually fabric filters..

## Active carbon adsorption

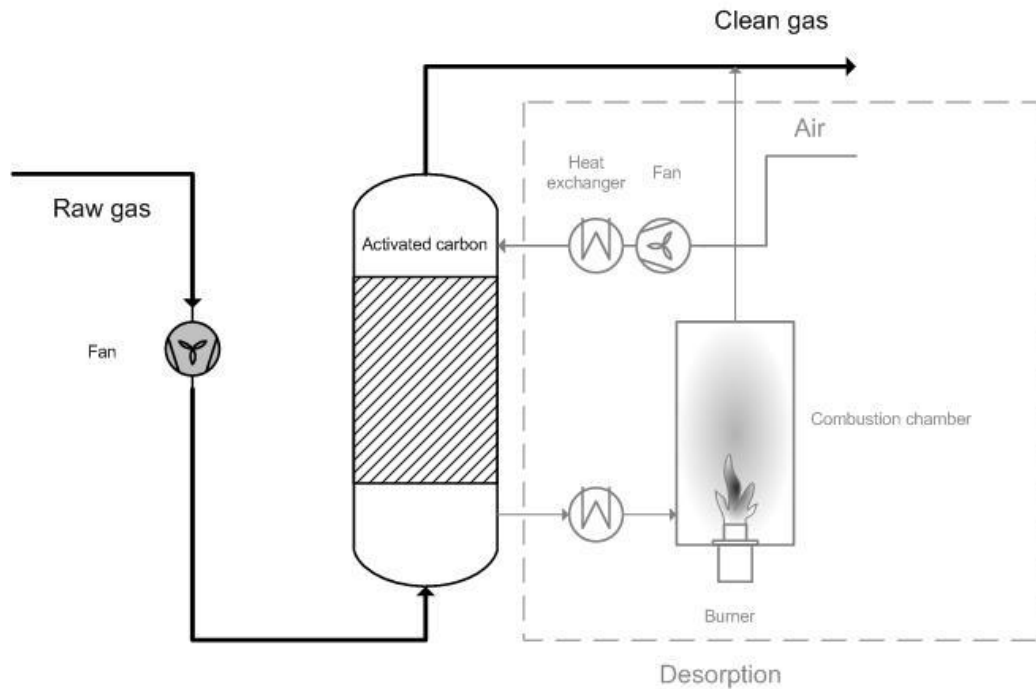

### Mechanical Volume Reduction

- Volume reduction (known as densification) is an important factor in the development of almost all solid waste management system.
- It is the term used to describe the process, there by the initial volume occupied by a waste is reduced.
- Usually by the application of force or pressure.
- In most cases vehicles equipped with compaction mechanism are used for the compaction of the waste.
- To increase the useful life of landfills, waste usually compacted before being covered, paper for recycling is baled and compacted at the processing centers.
- The vehicles used for collection of solid waste are equipped with compaction mechanism to increase the amount of waste collated per tip.
- Paper, card board, plastics and aluminum and tin removed from MSW for recycling are baled to reduce storage, handling and shipping cost to recyclable materials for MSW.

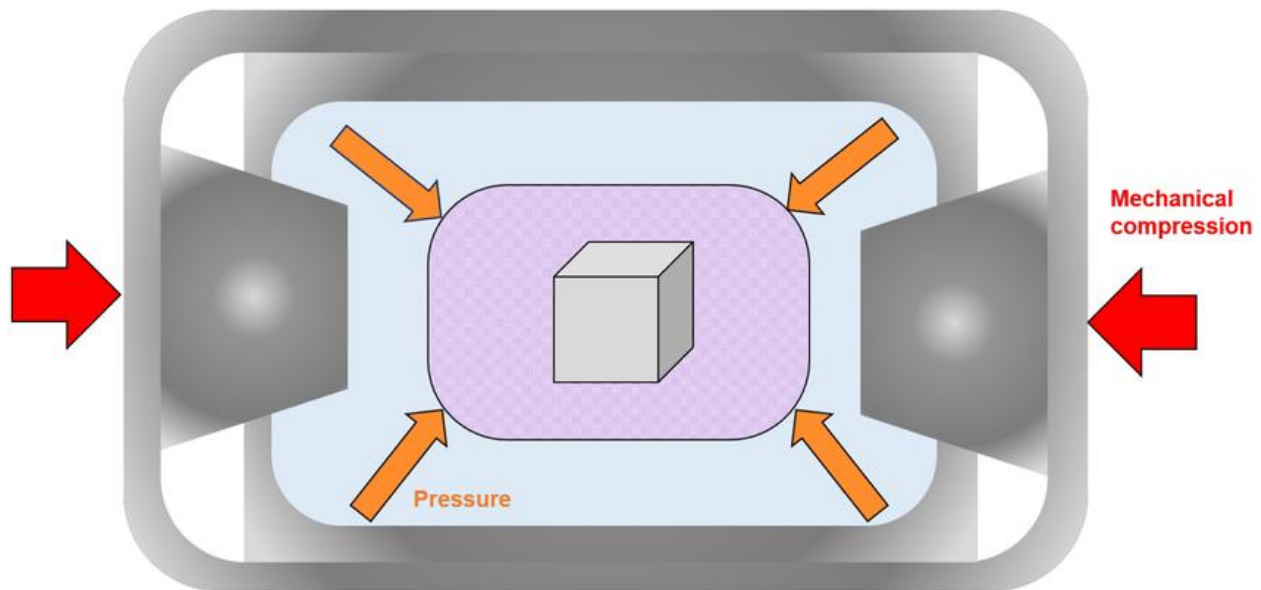

### **Low- Pressure Compaction:**

Typically low pressure compactors include those used at apartments and commercial establishments, baling equipment used for waste paper and cardboard while stationary compactors used at transfer station. Portable stationary compactors are being used increasingly by number of industries .

### **High Pressure Compaction:**

Recently a number of high pressures (up to 5000 lb/inch (353.27 kg/cm<sup>2</sup>)) Compaction systems specialized compaction equipment is used to produce Compressed solar waste in blocks or bales of various sizes. In one system the size of the completed block is about 4incx4incx16 inch and the density is about 1600-1850 lb/yd<sup>3</sup>. In another system pulverized waste are extracted after compaction in the form of logs approximately 9 inch in diameter. The volume reduction achieved with these high pressure compaction systems varies with the characteristics of waste. Typically, the reduction ranges from about 3 to 1 through 0 to 1.

## **Chemical Volume Reduction**

- In addition to mechanical volume reduction, various chemical processes have been used to reduce the volume of solid waste.
- Until the early 1970's open burning was a common practice at any disposal sites. In some parts of the world this method is still used.
- In the early part of the century chemical reduction was used to recovery grease from food waste and in the process the volume was reduced.
- Since the turn of the center, Incineration has been the method most commonly used to reduce the volume of waste chemically.
- Although other chemical process such as pyrolysis, hydrolysis and chemical conversion are also effective in reducing the volume of solid waste.
- Because incineration is now used both for volume reduction and for power production, chemical volume reduction technique can be best employed for the production of power in the processing techniques.

## **Mechanical Size Reduction**

- It is the term applied to the conversion of solid waste as they are collected into smaller places the objective of size reduction is to get a final product that is reasonably uniform and considerably reduce when compared to this original form.
- It is important to note that size reduction does not necessarily impale volume reduction.
- In some situations, the total volume of the material after size reduction may be greater than that of the original volume.
- In practice the terms shredding, grinding are used inter changeably to describe mechanical size reduction of solid waste.
- Size reduction is an important factor not only in the design and operations of solid waste management systems but also in the recovery of materials for use and for conversion of energy.
- Some form of size reduction is necessary for the liquid transport of solid waste to achieve a high density at a lower compactive effort, waste are shredded before they are bated. The disposal of shredded waste in landfills without use of daily cover is another important application of size reduction.

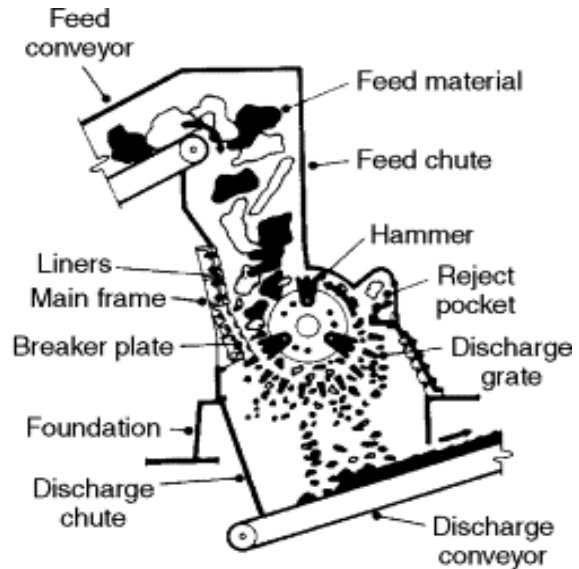
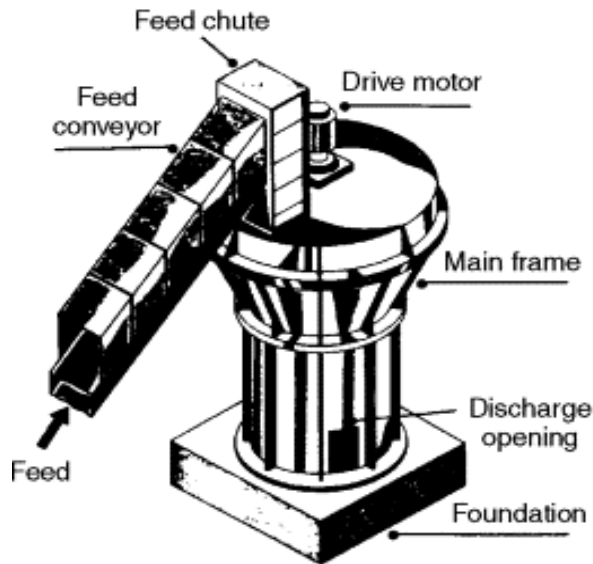

### Size Reduction Equipment's

The types of equipment's that have been used for reducing the size for homogeneous solid waste includes small grinders, chippers, big grinders, Jaw crushers, ramp mills, shredders, hammer mills, etc. and hydro power. Type's mode of action and applications of equipment's used for mechanical size reduction.

TYPE	MODE OF ACTION	APPLICATION
Small grinders	Grinding, mashing	Organic residential solid waste
Chippers	Cutting, slicing	Paper, card board, tree trimmings, yard waste and plastic
Law crushers	Crushing, breaking	Large solids
Cash mills	Shedding, tearing	Moistened solid waste, most commonly used in MSW

Shredder	Shearing, tearing	All types of municipal waste
Hammer mill	Breaking, cutting, crushing	All types of municipal waste most common equipment for reducing size and homogenising solid waste
Hydro pulper	Shearing, tearing	Ideally suited for use with palpable waste like paper, wood chips, etc, used primarily in the paper industry. Also used to destroy paper records.

### **Component Separation**

It is a necessary operation in the recovery of resources from solid waste and where energy and conversion products are to be recovered from processed wastes. The required separation may be accomplished manually or mechanically. When manual separation is used, pre-processing of the waste is not required in most mechanical techniques; however some form of size reduction is required as a first step.

### **Hand Sorting**

In manual separation of solid waste, components can be accomplished at the source where solid waste are generated at a transfer station at a centralized processing station or at disposal site. The number of and types of components sorted depend on the location and the resale market. Typically, the components include newspaper, aluminum and glass from residential sources, cardboard and

high quality paper, metals and wood from commercial and industrial sources, metals, wood and bulky items of value from transfer stations and disposal sites.



## Air Separation



Air classification has been used for a number of years in industrial operations for the separation of various components from dry mixtures. In solid waste

- i) Particles are fed mechanically
- ii) Particles are inspected optically

iii) Inspection results are evaluated electronically

iv) Pre-determined types of particles are removed by a precisely timed air blast.

### Electro Static Separation

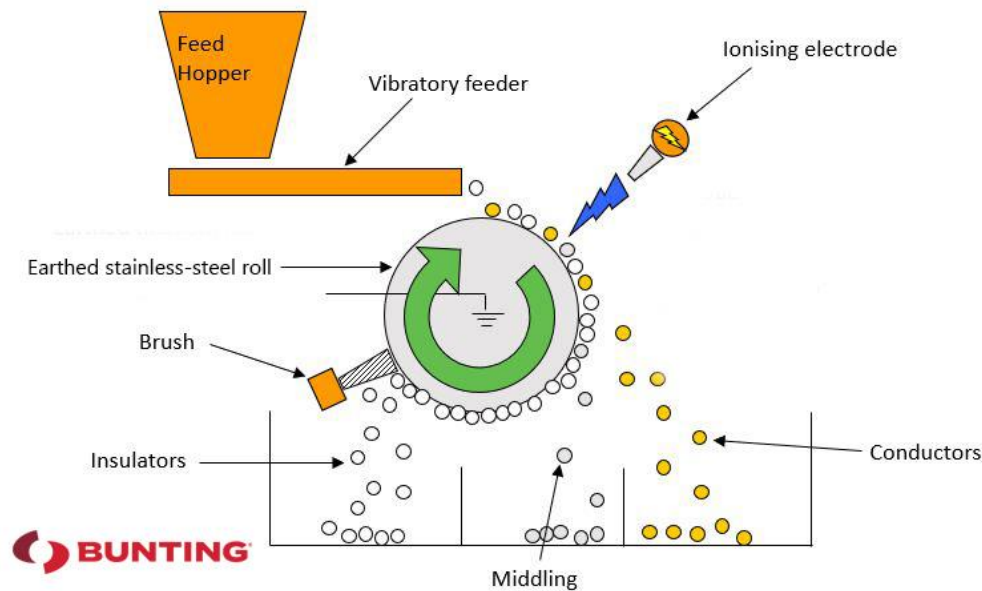

High voltage electro static fields can be used to separate glass from the heavy fraction of air classified waste. A vibrating pedometer feeds waste to a negatively charged rotating drum and a positive electrode near the drum and the feeder induces a charge in the waste particles. Non- conductors such as glass and clay retain the charge whereas crystalline materials such as rock loose it rapidly. The drum holds non-conductors and the remaining material drops off.

### Heavy Media Separation

Although the removal of aluminum can be accomplished in a number of different ways, heavy media separation is the best process for which the greatest operating experience exists principally in the automobile recovery industry. In this process feed stock i.e. rich in aluminum, such as air classified solid waste where in ferrous metals and glass has been removed, is dumped into a liquid which has a high specific gravity. The sp. Gravity is maintained at higher level that will permit

aluminum to float and other materials remain submerged. At present the major disadvantage of this process is that the optimum size plant requires about 2000-3000 tons per day of feedstock.

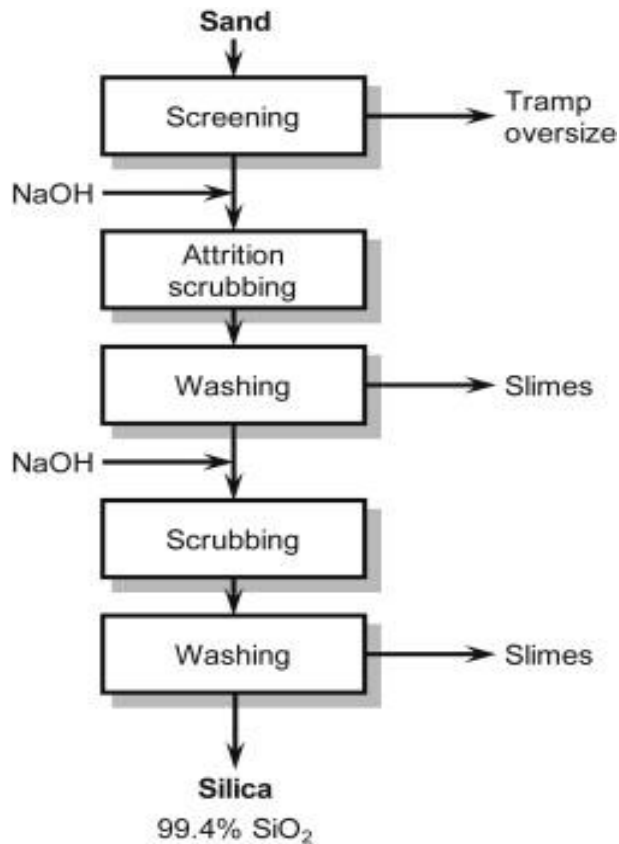

### Liner Induction Separation

A new type of magnetic appears to offer great promise for removing aluminum from relatively small quantities of municipal waste. Design of these systems is based on fundamental electrical principles classification is used to separate the organic material called the lighter fraction from the heavier inorganic material called the heavier fraction. Practically speaking, this involves the separation of paper products, plastic materials and other light organic materials from the shredded waste stream.

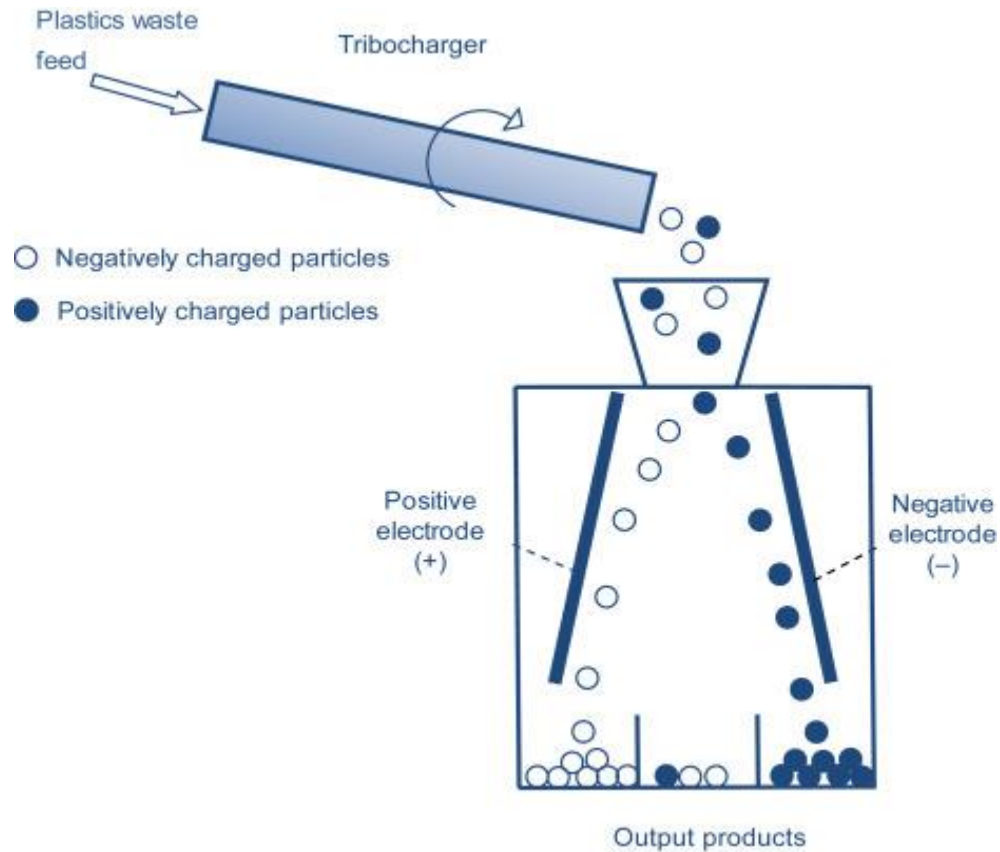

## Magnetic Separation

- The most common method of recovery ferrous scrap from shredded solid waste involves the use of magnetic recovery systems.
- Ferrous materials are usually recovered either after shredding and before air classification or after shredding and the air classification or after shredding and before air classification or after shredding and the air classification.
- In some large installations, overhead magnetic systems have also been used to recover ferrous materials before shredding (Scalping).
- When waste is mass fired in municipal incinerators, magnetic separators are used to remove the ferrous materials from the incinerator residue.
- Magnetic recovery systems have also been used at landfill disposal sites.
- Over the years, various types of equipment's have been used for the magnetic separation of ferrous materials. The most common types are suspended magnetic drum.



## Screening

It involves the separation of mixture of materials of different sizes into two or more portions by means of one or more screen surfaces. Screening has been accomplished either. Wet or dry with the latter being most common in solid waste processing systems. Screening has a number of applications in solid waste resources and energy recovery systems and screens have been used before and after shredding and after air classification and before magnetic separation.

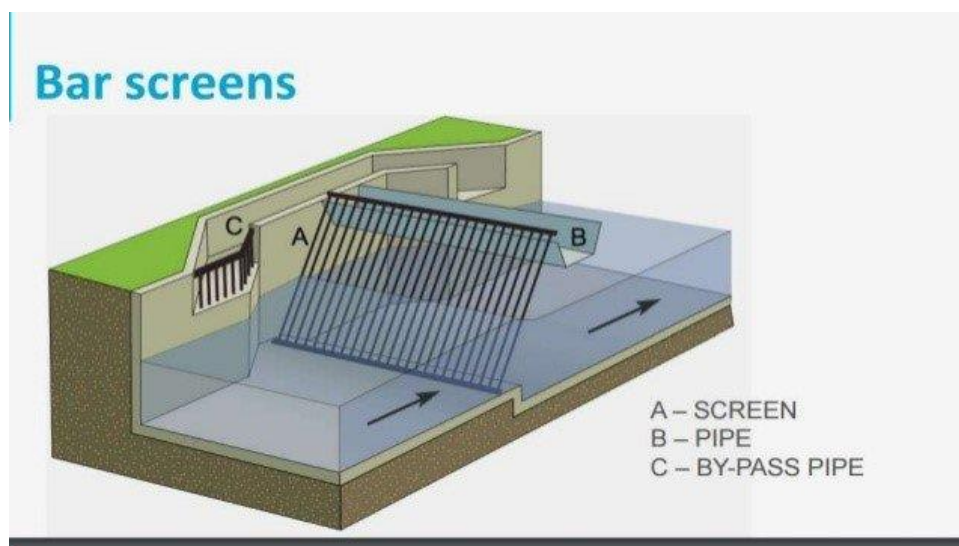

## Optical Sorting

Sorting of glass from opaque particles such as stones, ceramics, bottle caps and cork can be accomplished optically by identification of the transparent properties of glass, optical color sorting can be used to separate flint glass from mixed colored glass. Mixed colored glass can also be sorted into amber and green products. Functionally 4 basic operations are involved, they are:

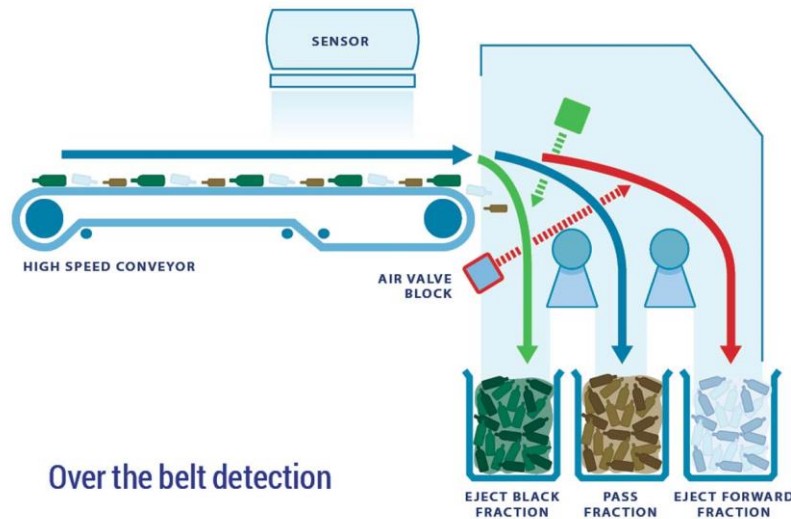

## Dewatering

The problem of sludge disposal from municipal waste water treatment plants has become critical. For many large communities in which the use of drying beds, lagoons or land spreading is no longer practical or economically feasible. In most cases some form of sludge dewatering has been adopted to reduce the liquid volume. Once dewatered the sludge can be mixed with other solid waste. The resulting mixture can be

- i) Incinerated to reduce the volume
- ii) Used for the production of recoverable by products
- . iii) Used for the production of compost
- iv) Buried in a land fill.

# **MODULE-3**

## **Composting**

Composting is a process in which organic materials undergo biological degradation to a stable nuisance free humus like end materials.

## **Aerobic Composting**

Aerobic composting is the most commonly used biological process for the conversion of the organic portion of MSW to a stable humus like material known as compost. All aerobic composting processes are similar, in that they have three basic steps.

1. Pre-Processing of the MSW
2. Aerobic decomposition of the organic fraction of the MSW.
3. Product Preparation and marketing.



Windrow, aerated static pile and in vessel are the three principal methods used for composting of the organic fraction of MSW, while these processes differ primarily in the method used to aerate the organic fraction of solid waste, the biological

principles remain the same and when designed and operated properly, all produce a similar-quality compost in approximately the same time period. Aerobic composting is defined as a process in which, under suitable environmental conditions, facultatively aerobic organisms principally there mephitic, utilize considerable amounts of oxygen in decomposing organic matter to a fairly stable humus. With the exception of plastic, rubber and leather components, the organic Fraction of most MSW can be considered to be composed of proteins, amino acids, lipids, Carbohydrates, Cellulose, lignin and ash. If these organic materials are subjected to aerobic micro-bacterial decomposition, the end product leaning after Microbiological, activity as essentially ceased is a humus material commonly known as compost

### **The general objectives of composting are**

1. To transform the biodegradable organic materials into a biologically stable material and in the process reduce the original volume of waste.
2. To destroy pathogens, insect eggs and other unwanted organisms and need seeds that may be present in MSW.
3. To retain the maximum nutrient (Nitrogen, phosphorous and potassium) content and
4. To produce a product that can be used to support plant growth and as a soil amendment.

In general, the chemical and physical characteristics of compost vary according to the nature of this starting material, the condition under which. The Composting operation was carried at and the of the decomposition. Some of the properties of compost that distinguish it from other organic materials are these

1. A brown to very dark brown color
2. A low carbon nitrogen ratio.
3. A continually a hanging nature due to the activities of micro organisms

4. A high capacity for cation exchange and water absorption. When added to soil, compost has been found to lighten heavy soils, to improve the texture of light sandy soils and to increase. The water retention capacity of most soils.

### Aerobic Composting Microbiology

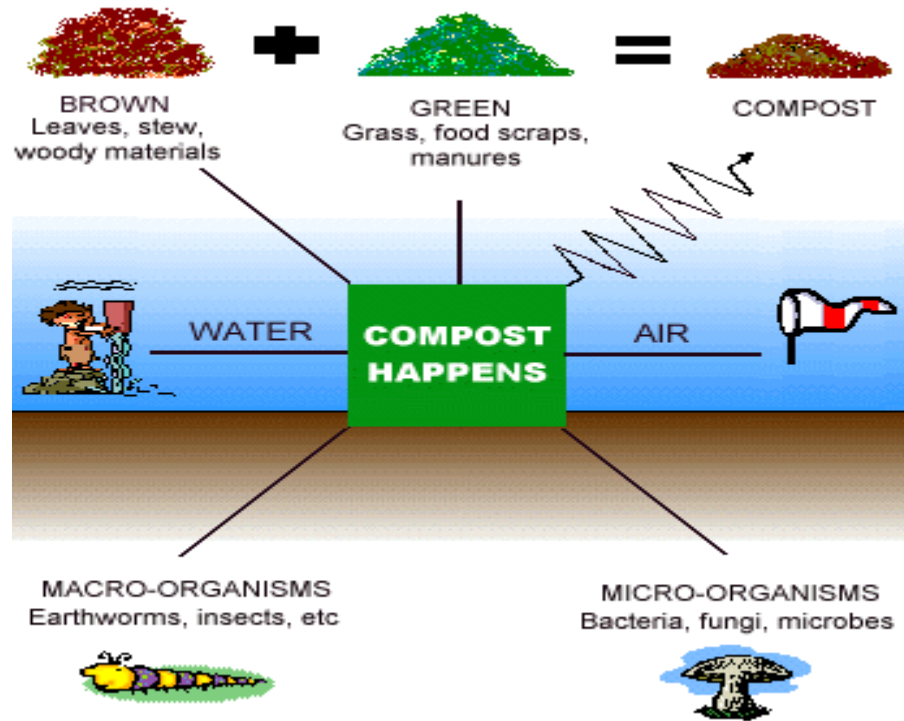

During the Aerobic Composting process, a succession of facultative and obligate aerobic micro-organisms is active. In the beginning phases of composting process, mesospheric bacteria are the most prevalent. After the temperatures in the compost site, thermophile bacteria predominate leading to thermophiles fungi, which appear after 5-10 days. In the final stages or Curing period as it is sometimes known, actinomycetes and molds appear because significant concentrations of these micro-organisms may not be present in same types of biodegradable waste (eg. Newspaper) It may be necessary to add them to the composting material as an additive. The microbiology of all aerobic composting process is similar. Critical parameters in the control of aerobic composting processes include moisture content, C/N ratio, and temperature for most biodegradable organic wastes, once the moisture content is brought to a suitable level (50 to 60% and the mass

aerated, microbial metabolism speeds up. The aerobic micro-organisms which utilize oxygen, Feed upon the organic matter and develop cell tissue from nitrogen, phosphorous, some of the carbon and other required nutrients, much of the organisms and is burned up .

### **Important Design Considerations For Aerobic Composting Process**

<b>ITEM</b>	<b>REMARKS</b>
Particle size	For optimum results the size of solid wastes should be between 25 and 75mm
Carbon and Nitrogen ratio (C/N ratio)	Initial carbon and nitrogen ratio (by mass) between 25 and 50 are optimum for aerobic composting. At lower ratios ammonal is given off. Biological is also impeded at lower ratios. At higher ratios. At higher ratios nitrogen may be a limiting nutrient.
Moisture Content	Composting time can be reduced by seeding with partially decomposed solid wastes to the extent of about 1 to 5 percent by weight, sewage sludge can also be added to prepared solid waste, where sludge is added, the final moisture content is the controlling.

Blending and Seeding	To prevent drying, caking and air channeling, material in the process of being composted should be mixed or turned on a regular Schedule or as required.
Air Requirements	The theoretical quantity of oxygen required can be estimated and air with at least 50% of the initial oxygen concentration remaining should reach all parts of the composting material for optimum results, especially in mechanical systems.
p <sup>H</sup> Control	To achieve an optimum aerobic decomposition, pH should remain at 7 at 7.5 range. To minimize the loss of nitrogen in the form of ammonia gas, p <sup>H</sup> should not rise above 8.5.

### Anaerobic Composting

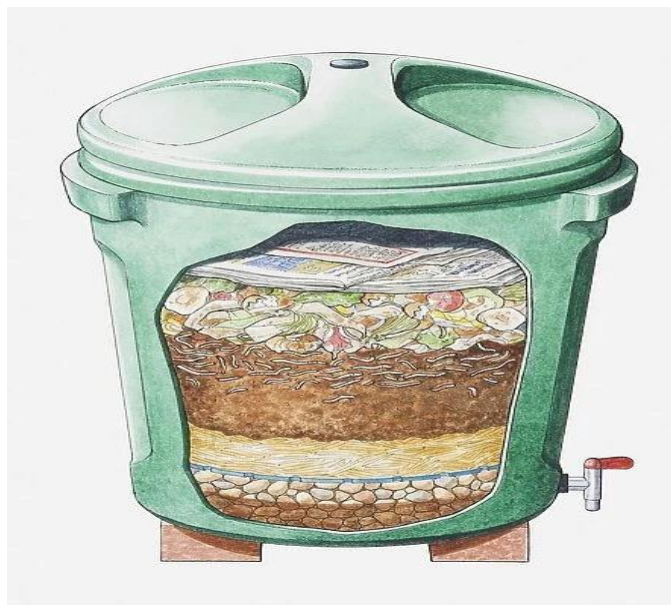



anaerobic bacteria ferments the break down products from the first group to simple organic acids.

The most common of which in anaerobic composting is acetic acid. This second group of micro-organisms (Called as non-mention organic) consists of Facultative and obligates an aerobic bacteria and are called as Acidogens or Acid formers. A third group of micro-organisms converts the hydrogen and acetic acid formed by the acid formers to methane gas and  $CO_2$ . The bacteria responsible for this conversion are strict Anaerobes called Methanogen and are called as Methanogen or Methane formers. In anaerobic fermentation, the Formation of methane takes place by.

1. The Conversion of  $CO_2$  and hydrogen to Methane and water
2. The Conversion of format and acetate to methane, carbon dioxide and water (Eq.2 2 3)

The Methanogens and Acidogens form a Syntrophic (Mutually beneficial) relationship in which the methanogens convert fermentation end products such as hydrogen, format and acetate to methane and  $CO_2$ .

The methanogens are able to utilize the hydrogen produced by acidogens, because of their efficient hydrogenase. The utilization of hydrogen, produced by the acidogens and other anaerobes, the methanogens is termed as interspecies hydrogen transfer.

In effect the methanogenic bacteria remove compounds that would airtibitbe growth of acidogens.

## Important Design Considerations For The Anaerobic Composting (Digestion)

ITEM	REMARKS
Size of material	Wastes to be digested should be shredded to a size that will not interfere with the efficient working or functioning of pumping and mixing operations. To achieve optimum results and to avoid scum build up, mechanical mixing is recommended.
Mixing Equipment	Although amounts of wastes varying from 50 to 90 % have been used 60% appears to be a reasonable

## Bangalore Process of Composting



In Bangalore process the Composting material is not turned and is allowed to remain in the plants for about 4 months or longer. The Method is as follows.

1. A loose layer of MSW is to be plead and spread at the bottom of the pit with the help of long handle rakes.
2. A shallow pit or trench is developed in the waste layer and might soil about 5cm thick is spread in this trench. Normally might soil flows readily by itself but a long handled broad-blade hoe can be used to spread it if necessary.
3. Succeeding layers of waste and might soil are added in a similar manner until the pit stack is about 30 cm above ground or pit curb.
4. Each layer of might soil should be immediately covered with waste and the top most layer of waste should be at least zero cm thick.
5. They composting mass develops a temperature of around 600 c in a few days and remain at the temperature for a considerable number of days.
6. After the material has been decomposed for several days the volume decreases and the piles settle to  $\frac{1}{2}$  to  $\frac{2}{3}$  of the original depth. New layers of might soil and waste can thus be added to the pit until the level is again above the pit curb. In raining weather, the top of the pit should be rounded to turn the water and prevent seepage into the pit.
7. The Pit may be covered with 5cm layer of earth to help prevent the escape of ammonia when the initial C/N ratio of material is too low. As well as to reduce the escape of odors.
8. The top 10-15 cm of Material in the pit do not decompose properly owing to the lower temperature active exposed surface. This material can be forked off the pit at the time the compost its removed and reused for covering another pit.
9. Fly control may also be improved by covering the compost pit tightly with a tarred cloth, sealed to the curb of the pit by a mud plaster.
10. After about 4-6 months the material has developed into humus. It is removed and put directly on the soil or screened.

## Indore Process of Composting

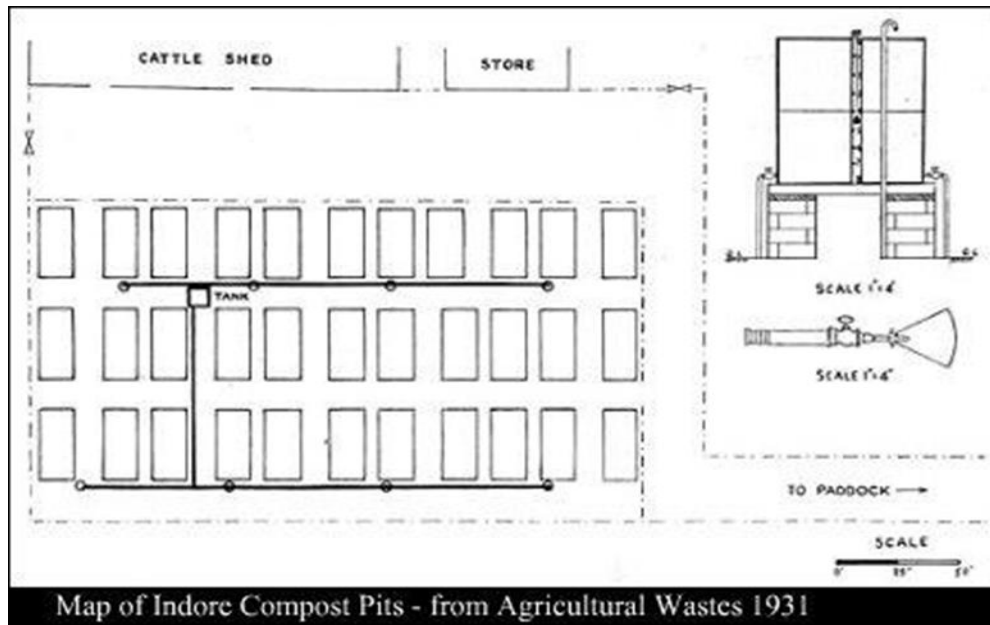

This process of composting is similar to that of Bangalore process except that the composting mass is turned. It is done to maintain aerobic conditions and to keep away obnoxious odor. It also keeps in maintaining high temperature more rapid and uniform decomposition and more effective fly control. The method is as follows.

1. The steps in putting the initial materials in the pit are more or less same as in the Bangalore process except that a small space about 60cm is left vacant at the end of the pit. The Vacant space is used to facilitate turning of the compost materials. The Thickness of bottom and intermediate layers is kept slightly less to obtain slightly higher M.C.
2. Since the material is turned, exposure of all the material to high temperature is assumed and higher M.C. does not present a problem in
3. Maintaining aerobic conditions. This actually permits the addition of higher proportion of might soil to the refuse. The Presence of odors is an indication of improper operation and should be used in the control of the process indication of odors in that,.

4. After 4 to 7 days of lading the pit contents must be turned. Turning performs 3 functions.

a. It completes the mixing of refuse and might soil

b. The material at top and sides which are not subjected to high temperature are also subjected to high temperature.

c. The materials are aerated which is an essential Feature of Aerobic stabilization. The Fly larvae, pathogens and parasites are destroyed by high temperature.

5. Since the volume of the material shrinks during composting, additional layers of might soil may be added at the time of first Turing of the materials.

6. Second-turn is made in 5-10 days after the first turn by which time al the traces of might soil disappear. Further turns are usually not necessary except when might soil was added at the time of first turn. It is seen that three turns spaced at 3 to 4 days apart, usually produce compost in about 15-20 days.

7. If larger amounts of wastes are received than the pit capacity, the process can be expedited by more frequent turns. This way seasonal Fluctuations in the quantity of repose can be accommodated.

### **Factors Affecting Composting**

The most important factors affecting the composting operations are given below.

1. Segregation of refuse
2. Grinding and shredding of refuse
3. C/N ratio
4. Proportion or blending of wastes
5. Moisture content (M.C)
6. Placement of Materials for composting
7. Temperature

8. Aeration
9. Organisms in composting
10. Use of inoculums
11. Reaction (pH Control)
12. Coloristic Conditions
13. Destruction of pathogenic organisms
14. Fly Control

**1. Segregation of Refuse:** Segregation is an important factor as they would create difficulties in subsequent processes of composting like shredding and grinding, glass bottles, tin cans, plastic materials can be easily segregated.

**2. Grinding and Shredding of Refuse:** Grinding and shredding of refuse makes the material more susceptible to bacterial invasion as more surface area is exposed to bacterial attack.

**3. C/N Ratio (Carbon/Nitrogen Ratio):** Decomposition of organic matter is affected by the presence of carbon and nitrogen. The C/N ratio represents the decomposition of organic matter is brought about by living organisms which use 'C' as a source of energy and 'N' for building cell structure since living organisms use about 30 parts of 'C' for each Part of 'N' an initial C/N ratio of 30 seems most favorable for ratio composting. The composting time can be decreased by decreasing C/N ratio below so. This ratio largely depends upon the composition of the MSW being composted

**4. Proportion or Blending of Wastes:** C/N ratio and moisture content are the two main factors which are to be considered in blending. There is no need for blending when C/N ratio lies between 30 to 40. Materials too dry for good composting and materials too wet to compost without nuisance should be blended in proper proportions. Some-times even earth is added to the organic materials with the idea of increasing the number of microorganisms so as to expedite composting. Ash and cinders contain phosphorous and potash, desirable for soil but they should not be

put in large amount in compost piles. This is because they increase pH and help in loss of nitrogen during composting. Sewage sludge can also be added to MSW for composting.

**5. Moisture Content (M.C):** Aerobic Composting can proceed at any moisture content between 30% and 100% provided adequate aeration is maintained. But however a high M.C. Must be avoided because water displaces all from the interstices and availability of oxygen is decreased n the other hand, too low a M.C. deprives the organisms of water needed for their metabolism. For aerobic composting, M.C. for the optimum conditions of composting fell in the range 40% .In anaerobic composting the maxim M.C. is not as important. If the Composting procedure is to have initial aerobic conditions to produce high temperature lasting a few days for the destruction of pathogenic, organisms, followed by anaerobic composting, the maxim initial M.C may be as high as 65-85% depending on the character of the composting material.

**6. Placement of Materials for Composting:** For the aerobic decomposition of M.S.W. open pile or window placed on the ground or on a paved surface or pit placed in a shallow pit are the mostly used methods. If composting process is to be maintained aerobic throughout, frequent turning becomes essential, on the other hand if composting is to be entirely anaerobic, pits about in deep and varying in length and breadth in accordance with the daily quantity should be used.

**7. Temperature:** In aerobic composting proper temperature is a very important factor. High temperature are essential for the destruction of pathogenic organisms and undesirable seed composting also proceeds much more rapidly in the thermopile temperature ranges. The optimum temp range 550 -700 c, around 600 c usually being the most satisfactory. The temperature curve for the interior of a pile of shielded MSW usually a temperature of 45-500 c is obtained in the first 24 hrs of composting and 60+700 c in about 2-5 days. The final decline in temperature is more gradual than the original size and indicates that the material has become well stabilize. A drop in temperature in the pile before the material is stabilized indicates that the pile is becoming anaerobic and should be aerated. The variations in M.C between 30% and 75% have little effect on the maxim temperature.

**8. Aeration:** Aeration is essential for thermopile aerobic, composting and also for reducing high initial M.C Aeration also avoids anaerobic conditions, helps maintain high temperature and fly control.

**9. Organisms in Composting:** In aerobic composting a wide variety of micro-organisms have a variety of specific. Functions and that no single organism no matter how active can compose with a mixed population in producing rapid stabilization compostable waste materials normally contain a large number of many different types of bacteria, fungi, moulds and other living organisms.

**10. Use of Inoculum:** Enzymes, hormones, preserved living, organisms, biocatalysts are some of the inoculums which may be used to bring about rapid decomposition of the compostable, matters. But there are convicting evidences that inoculums and other additives are not essential of other conditions favorable to composting are maintained.

**11. Reaction (pH CONTROL):** The initial pH of compostable materials lies usually between '5' and '7' wastes containing ash may be having higher pH value. If the material has undergone putrefaction before being received for composting pH will be about '5', since the optimum pH for most organisms is around 6.5 to 7.5 H would be beneficial of pH could be maintained in that range. The usual waste materials available for composting usually present no problem of pH control.

**12. Climatic Conditions:** Climatic Conditions like temperature, wind and rainfall influence the composting operation. Wind lower the temperature on the wind ward side of the compost stack. Rains present more of problems when composting done in pits. Shredding and grinding of the materials also become difficult. Heavy snow fall greatly hinders contiguous composting operations.

**13. Destruction of Pathogenic Organisms:** Aerobic composting at high temperatures is effective in destroying pathogenic organisms. Almost all the disease bearing organisms die away at much lower temperature than the maxim. Temp found inside the composting piles. Frequent turning also helps in the elimination of disease producing organisms.

**14. Fly Control:** The composting materials are excellent media for the breeding and development of a large fly population. Branding turning and systematic cleanliness are found most effective for controlling files.

## Composting Techniques

The two principal methods of composting may be classified as agitated and state. In the agitated method, the material to be composted control the temperature and to mix the material to obtain a more uniform product. in the static method, the material to be composted remains static and air is blown through the composting material. The most common agitated and static methods of composting are known as windrow and static pile methods respectively. Composting systems in which the composting operation is carried out in a reactor of some type are known as in vessel composting systems.

## Vermicomposting



is the product of the composting process using various species of worms, usually red wigglers, white worms, and other earthworms, to create a mixture of decomposing vegetable or food waste, bedding materials, and vermicast. Vermicast (also called worm castings, worm humus, worm manure, or worm feces) is the end-product of the breakdown of organic matter by earthworms. These

castings have been shown to contain reduced levels of contaminants and a higher saturation of nutrients than the organic materials before vermicomposting. Vermicompost contains water-soluble nutrients and is an excellent, nutrient-rich organic fertilizer and soil conditioner. It is used in farming and small scale sustainable, organic farming. Vermicomposting can also be applied for treatment of sewage sludge. Furthermore, a variation of the process is vermifiltration (or vermidigestion) which is used to remove organic matter, pathogens and oxygen demand from wastewater or directly from blackwater of flush toilets.

## Suitable worm species

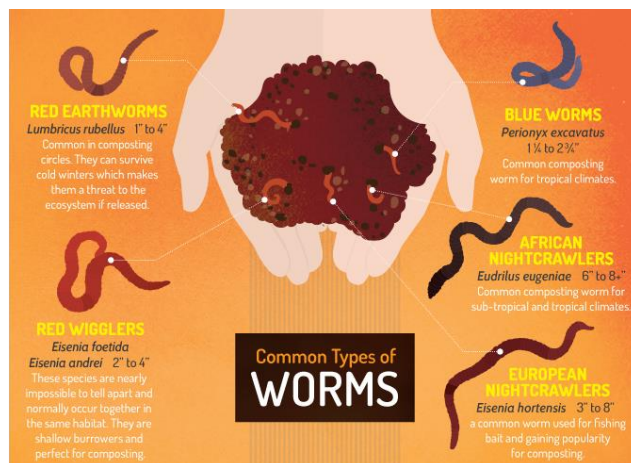

One of the species most often used for composting is the red wiggler or tiger worm (*Eisenia fetida* or *Eisenia andrei*); *Lumbricus rubellus* (a.k.a. red earthworm or dilong (China)) is another breed of worm that can be used, but it does not adapt as well to the shallow compost bin as does *Eisenia fetida*. European nightcrawlers (*Eisenia hortensis*) may also be used. Users refer to European nightcrawlers by a variety of other names, including dendrobaenas, dendras, and Belgian nightcrawlers. African Nightcrawlers (*Eudrilus eugeniae*) are another set of popular composters. *Lumbricus terrestris* (a.k.a. Canadian nightcrawlers (US) or common earthworm (UK)) are not recommended, as they burrow deeper than most compost bins can accommodate. Blueworms (*Perionyx excavatus*) may be used. These species commonly are found in organic-rich soils throughout Europe and North America and live in rotting vegetation, compost, and manure piles. They may be an invasive species in some areas. As they are shallow-dwelling and feed

on decomposing plant matter in the soil, they adapt easily to living on food or plant waste in the confines of a worm bin. Composting worms are available to order online, from nursery mail-order suppliers or angling shops where they are sold as bait. They can also be collected from compost and manure piles. These species are not the same worms that are found in ordinary soil or on pavement when the soil is flooded by water.

## Large Scale



- Large-scale vermicomposting is practiced in Canada, Italy, Japan, India, Malaysia, the Philippines, and the United States.
- The vermicomposting may be used for farming, landscaping, to create compost tea, or for sale.
- Some of these operations produce worms for bait and/or home vermicomposting.
- There are two main methods of large-scale vermiculture. Some systems use a windrow, which consists of bedding materials for the earthworms to live in and acts as a large bin; organic material is added to it.

- Although the windrow has no physical barriers to prevent worms from escaping, in theory they should not due to an abundance of organic matter for them to feed on.
- Often windrows are used on a concrete surface to prevent predators from gaining access to the worm population.
- The windrow method and compost windrow turners were developed by Fletcher Sims Jr. of the Compost Corporation in Canyon, Texas.
- The Windrow Composting system is noted as a sustainable, cost-efficient way for farmers to manage dairy waste.
- The second type of large-scale vermicomposting system is the raised bed or flowthrough system.
- Here the worms are fed an inch of "worm chow" across the top of the bed, and an inch of castings are harvested from below by pulling a breaker bar across the large mesh screen which forms the base of the bed.
- Because red worms are surface dwellers constantly moving towards the new food source, the flow-through system eliminates the need to separate worms from the castings before packaging.
- Flow-through systems are well suited to indoor facilities, making them the preferred choice for operations in colder climates.

## Small Scale



- For vermicomposting at home, a large variety of bins are commercially available, or a variety of adapted containers may be used.
- They may be made of old plastic containers, wood, Styrofoam, or metal containers.
- The design of a small bin usually depends on where an individual wish to store the bin and how they wish to feed the worms.
- Some materials are less desirable than others in worm bin construction.
- Metal containers often conduct heat too readily, are prone to rusting, and may release heavy metals into the vermicomposting.
- Styrofoam containers may release chemicals into the organic material. Some cedars, Yellow cedar, and Redwood contain resinous oils that may harm worms, although Western Red Cedar has excellent longevity in composting conditions.
- Hemlock is another inexpensive and fairly rot-resistant wood species that may be used to build worm bins.
- Bins need holes or mesh for aeration. Some people add a spout or holes in the bottom for excess liquid to drain into a tray for collection.
- The most common materials used are plastic: recycled polyethylene and polypropylene and wood.
- Worm compost bins made from plastic are ideal, but require more drainage than wooden ones because they are non-absorbent.
- However, wooden bins will eventually decay and need to be replaced. Small-scale vermicomposting is well-suited to turn kitchen waste into high-quality soil amendments, where space is limited.
- Worms can decompose organic matter without the additional human physical effort (turning the bin) that bin composting requires.
- Composting worms which are detritivorous (eaters of trash), such as the red wiggler *Eisenia fetida*, are epigeic (surface dwellers) together with symbiotic associated microbes are the ideal vectors for decomposing food waste.
- Common earthworms such as *Lumbricus terrestris* are anecic(deep burrowing) species and hence unsuitable for use in a closed system.
- Other soil species that contribute include insects, other worms and molds. There may be differences in vermicomposting methods depending on the climate. It is

necessary to monitor the temperatures of largescale bin systems (which can have high heat-retentive properties), as the raw materials or feedstock's used can compost, heating up the worm bins as they decay and killing the worms.

- The most common worms used in composting systems, red worms (*Eisenia foetida*, *Eisenia andrei*, and *Lumbricus rubellus*) feed most rapidly at temperatures of 15–25 °C (59-77 °F). They can survive at 10 °C (50 °F). Temperatures above 30 °C (86 °F) may harm them.
- This temperature range means that indoor vermicomposting with redworms is possible in all but tropical climates.
- Other worms like *Perionyx excavates* are suitable for warmer climates. If worm bin is kept outside, it should be placed in a sheltered position away from direct sunlight and insulated against frost in winter.

## **Mechanical Composting**

- Though manual methods are preferable in countries where labor is comparatively cheap, mechanical processes are preferred (Gotaas 1956) where higher labor costs and limitations of space exist.
- In 1922, Becari in Italy patented a process using a combination of aerobic and anaerobic decomposition in enclosed containers. The first full scale plant was established in 1932 in the Netherlands by a nonprofit utility company-VAM using Van Maanen Process in which raw refuse is composted in large windrows, which are turned at intervals by mobile cranes moving on rails.
- This Process was developed in Denmark in 1930. Several other processes were subsequently developed using different methods of processing of solid waste using different designs of digester.
- Unit Processes A mechanical composting plant is a combination of various units which perform specific functions. Solid waste collected from various areas reaches the plant site at a variable rate depending upon the distance of collection point.
- As the compost plant operates at a constant rate, a balancing storage has to be provided to absorb the fluctuations in the waste input to the plant. This is provided in a storage hopper of 8 to 24 hours storage capacity, the exact value

depending upon the schedule of incoming trucks, the number of shifts and the number of days the plant and solid waste collection system works.

- The waste is then fed to a slowly moving (5metres/minute) conveyor belt and the non-decomposable material such as plastics, glass, metals are manually removed by laborers standing on either side of the conveyor belt.
- The laborers are provided with hand gloves and manually remove the material from the moving belt (the thickness over the belt is kept less than 15cms) and the removed material is stored separately. Magnetic pulley system .
- Majority of the metals are recycled at the source itself and hence are not contained in the waste. Magnetic removal of metals hence is not very efficient and therefore not used in India.
- In developed countries glass and metals are present in larger concentration and are removed by using ballistic separators. In these units, the waste is thrown with a large force when different constituents take different trajectories and get separated.
- This unit is energy intensive and due to smaller content of glass and metals in Indian municipal solid waste, it is not used in India.
- The waste is thus subjected to size reduction when the surface area per unit weight is increased for faster biological decomposition.
- Size reduction also helps in reducing fly ash. The metals are then removed from the waste by either a suspended magnet system or a breeding in the decomposing mass. This is commonly carried out either in Hammermills or Rasp mills. Hammermills are high speed (600-1200 revolutions per minute) compact machines but consume large energy. Rasp mills are slow moving large units that require lesser energy.
- The capital cost of a hammer mill is less but its operating cost is more than that of a rasp mill mainly due to the larger energy requirement as well as more frequent replacement / retipping of hammers.
- The stabilization is carried out in open windrows provided over flagstone paved or cement concrete paved ground. These windrows are turned every 5 days to ensure aerobic decomposition.
- Various types of equipment such as front end loaders/windrows reshifters are used for turning of windrows. At the end of the 3 to 4 weeks period, the

material is known as green or fresh compost wherein the cellulose has not been fully stabilized. It is hence stored in large sized windrows for 1-2 months either at the plant or the farms.

- At the end of the storage period, it is known as ripe compost. It may be sometimes subjected to size reduction to suit kitchen garden and horticulture requirements.

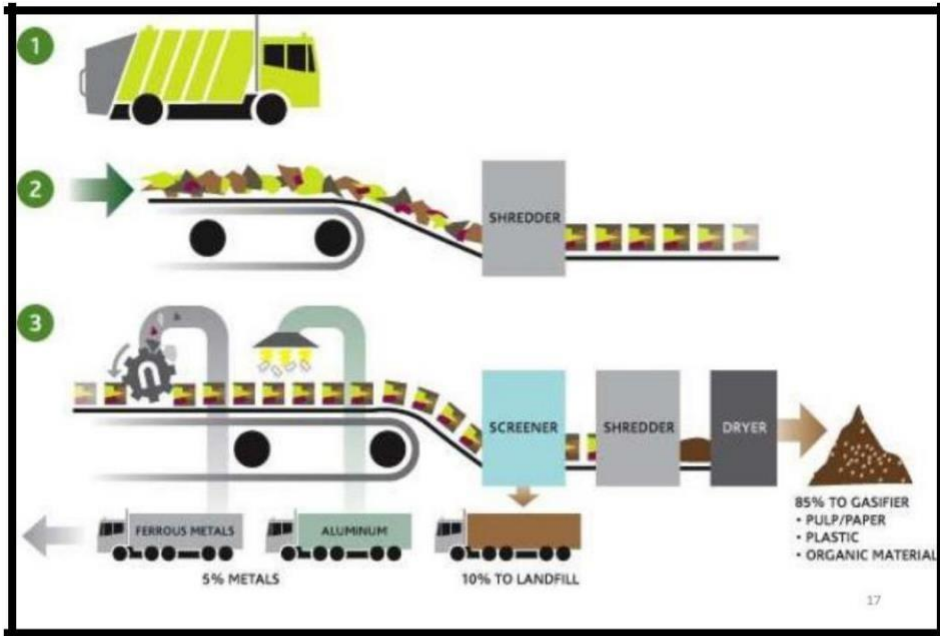

## MECHANICAL COMPOSTING

- It requires small area compare to trenching and open windrow composting.
- The stabilization of waste takes 3 – 6 days.
- The operation involved are
  - Reception of refuse
  - Segregation
  - Shredding
  - Stabilization
  - Marketing

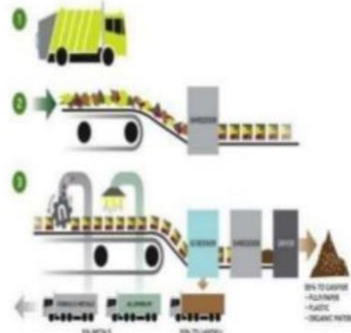

## Window Composting



- It is one of the oldest methods of composting a windrow can be constructed by forming the organic material to be composted into windows 2.5 to 3m height by 6 to 8m wide at the base.
- A minimal system could use a front end-loader system would work, it could take up to three to five years for complete degradation.
- Also such a system would probably emit objectionable odors', as part of the window will likely be anaerobic.
- A high rate window system employs windrows with a smaller cross section, typically 2-2.3m by 4.5m wide.
- Before the windows are formed organic material is processed by shredding and screening it to approximately 2.5-7.5m and the M.C. is adjusted to 50 to 60%.
- High rate systems are turned up to twice per week while the temperature is maintained at or slightly above 550 C.
- Turing of the windows is often accompanied by the release of offensive odors complete composting can be accomplished in three to four weeks.

- After the turning period, the compost is allowed to cure for an additional 3 to 4 weeks without turning. During the curing period, residual decomposable organic materials are further reduced by fungi and action mycetes.

### Sanitary Landfilling:

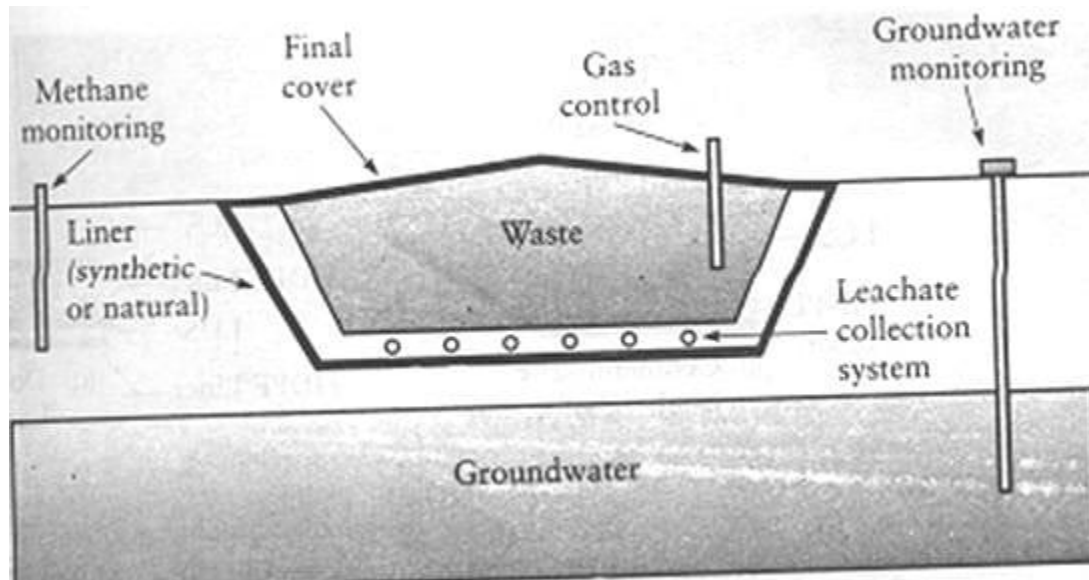

**Introduction:** Landfills have been the most economical and environmentally acceptable method for the disposal of solid waste. Even with implementation of waste reduction, recycling and transformation technologies, disposal of residual solid waste still remains an important component of an integrated solid waste management strategy. Land fill management incorporates planning, design, operation, closure and post closure control of landfills. Based on the past experience throughout the world, land disposal in the form of sanitary land fill has proved to be most economical and acceptable method for the disposal of solid waste

### Advantages and Disadvantages Of Sanitary Landfill:

<b>ADVANTAGES</b>	<b>DISADVANTAGES</b>
1 Share land is available, a sanitary landfill is usually the most	In highly populated areas suitable land may not be available within
2 Economical method of solid waste disposal.	Economical hauling distance.
3 The initial investment is low compared with other disposal methods like incineration .	Proper sanitary landfill standards must be followed to daily or the operation may result in an open dump.
4 sanitary landfill, is a complete or final disposal method as compared to incineration and composting which require additional treatment or disposal operators for clinical waste, unusable materials, etc.	Sanitary landfills located in residential, areas can provoke extreme public opposition.
5 A sanitary landfill can receive all types of solid waste, eliminating the necessity of separate collections.	A completed land fill will settle gradually and require periodic maintenance.

## **Methodology Placement of Waste In The Sanitary Landfill:**

- Once the land fill sites have been prepared, the next step in the process involves actual placement of waste materials.
- The waste is placed incense beginning along the compaction face contriving upwards and outwards of the face.
- The waste deposited in each operating period and (usually one day forms an individual cell) waste deposited by vehicles are spread out in 10-24 inch layers and compacted.
- Typical cell height varies from 8-12 feet. Length of working face varies with site conditions and size of operation.
- The working face is the area of the land fill where the solid waste is unloaded, placed and compacted during a given operating period.
- Width of the cell varies from 10-30 feet. All exposed faces of the cell are covered with thin layer of soil 6-12 inches thick of the end of each operating period.
- After are or more lifts have been placed horizontal gas recovery trenches can be excavated in the completed surface.
- The trenches are filled with gravel and perforated plastic pipes are installed in trenches. Gas is extracted through pipes depending on the landfill, additional leachate collection facilities may be placed in lifts.
- A cover layer is applied to the completed landfill section the final cover is designed to minimize infiltration of leachate and also cover is landscaped to control erosion.
- Vertical gas extraction systems may be installed through completed landfill surface and the whole system is tied together and routed to energy recovery facilities. Reactions in in sanitary landfills.
- The various reactions in sanitary land filling are
  - i) Biological reactions
  - ii) Chemical reactions
  - iii) Physical reactions

## **Biological Reactions**

- The most important biological reactions that occur in landfills are those involving organic matter in MSW that led to the development of landfill gases and liquids.
- The biological decomposition process usually proceeds aerobically for some short period immediately after deposition of waste until the oxygen initially present is depleted.
- During Aerobic decomposition CO<sub>2</sub> is the principle gas produced. Once all the available oxygen has been produced.
- Once all the available oxygen has been consumed, the decomposition becomes Anaerobic and the organic matter B converted to CH<sub>2</sub> and CH<sub>5</sub> and trace amounts of Ammonia, H<sub>2</sub>. many other chemical reactions are biologically mediated as well.

## **Chemical Reactions**

- Important chemical reactions that occurs within the landfill includes dissolution and suspension of material and biological conversion products in the liquid percolating through waste evaporation and vaporization of chemical compounds and water into evolving landfill gas.
- Sorption of volatile and semi volatile organic compounds (OCs ) into the landfill materials, de-halogenations and decomposition of organic compounds and oxidation reduction reactions affecting metals and solubility of metal salts.
- The dissolution of biological conversion products and other compounds, particularly of organic compounds into leachate is of special materials because these materials can be transported out of the leachate.
- These organic compounds can be subsequently released into the atmosphere either through soil or from uncovered leachate recovery facilities.
- Other important chemical reactions include those between certain organic compounds and clay liners which may alter the structures and portability of the liner material.

## **Physical Reactions**

- Among the more important physical changes in landfills are the lateral diffusion of gases in landfill and emission of land fill gases to the surrounding environment movement of leachate within the soil and into the landfill and into the underlying soil and settlement caused by decomposition of landfill materials.
- Land fill gas movements and emission are very important in management as gas B evolved within, a land fill, Internal pressure may build causing landfill to crack and leak.
- Though the water may enter into the landfill and enhance the gas production rate causing still note cracking and escaping landfill gases may carry trace cosenogenic substances into the surrounding environment.
- Because landfill gas usually has a high methane content, these may be a combustion/ or explosion hazard.
- Leachate migration B another important concern, it may transfer and transport the dangerous materials to new location.

**Sanitary Landfilling Methods:** The principal methods used for the land filling of MSW are

- i) Excavated cell/Trench method
- ii) Area method/ Ramp method
- iii) Canyon/ Depression method

## Excavated Cell or Trench Method & Area Method:

### Trench Method



- The excavated cell/ trench method of land filling is ideally suited through areas where an adequate depth of cover material is available at the site and where the water table is not near the surface.
- Typically, S.W. are placed in cells or trenches excavated in the soil. The soil excavated from the site is used for daily and final cover.
- The excavated cells/ trenches are usually lined with synthetic membrane liners or low permeability clay or combination of the two to limit the movement of land fill gases and leachate.
- Excavated cells are typically square up to 1000ft in width and length, with side slopes of 1:5:1 to 2:1 in length, 3-10 ft in depth, and 15-50 ft in width.
- Landfills are allowed to construct below the high ground, water level if special provisions are made to prevent ground water from entering the landfill and to contain or eliminate the movement of leachate or gases from completed cells.
- Usually the site is dewatered, excavated and then lined in compliance with local regulation the dewatering facilities are operated until the site is filled to avoid the creation of uplift pressures that could cause the liner to leave and rupture.

## Area – Method (Ramp Method)

### Area Method (Above Ground level)

- Used on flat ground or terrain is unsuitable for the excavation of trenches.
  - Before actual land filling, an earthen levee is constructed against which wastes are placed in thin layers and compacted.
  - Thickness of layer reaches a height of 200 to 300 cm.
  - Cover material of 15 to 30 cm thickness is placed after each layer.
  - A completed lift including the cover is called a cell.
- 
- This method is used to dispose of large amounts of solid waste.

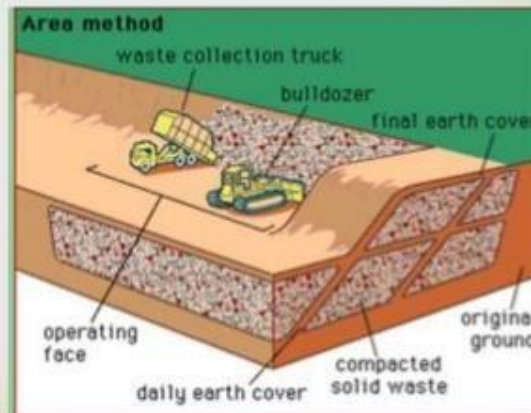

Is used when the terrain is unsuitable for the excavation of cells or trenches in which to place the S.W. In high ground water conditions necessitate the use of area method. Land fill site preparation include the installation of liner and leachate control system cover material must be hauled in by truck and earth moving equipment from adjacent land and from borrow pit areas. In locations with limited availability of materials that can be used as cover, compost produced from yard waste and M.S.W has been used successfully as inter mediate cover material. Other techniques that have been used include the use of movable temporary cover materials such as soil and geo membranes. Soil and Geomembranes placed temporarily over a completed cell can be removed before the next lift is begin.

## Canyon or Ravine:

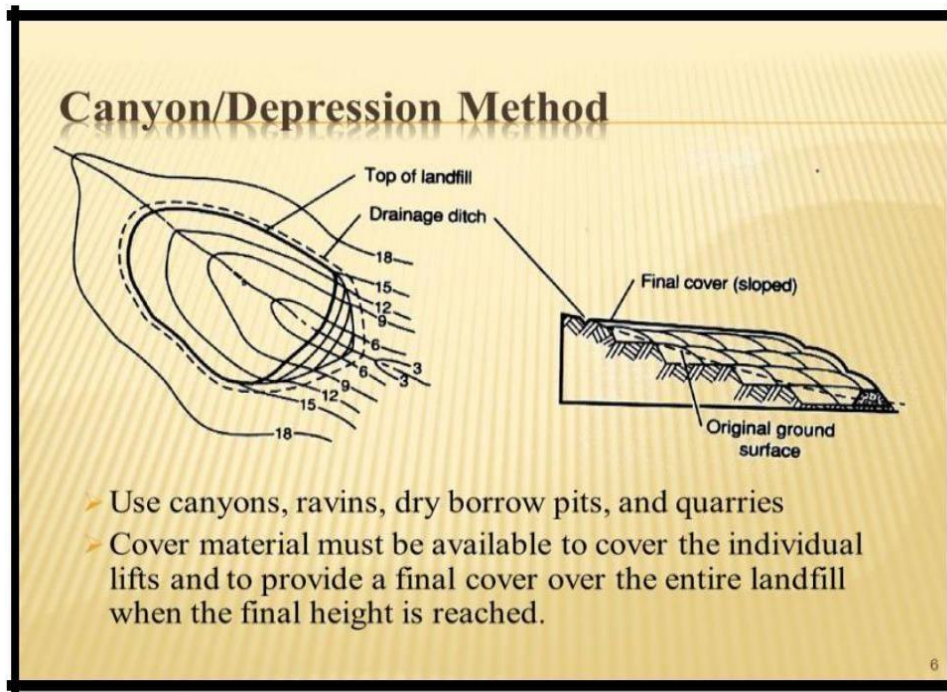

Canyons, ravines, borrow pits and quarries have been used for landfills. The Techniques to place and compact solid waste in canyons or depression landfills vary with

- i) Geometry of site
- ii) Characteristics of available cover material
- iii) Hydrology and Geology of site
- iv) Type of leachate and gas control facilities to be used
- v) Access to the site In a canyon site filling starts at the head (higher) end of the canyon and ends at the mouth.

This practice prevents accumulation of water behind landfill. Waste usually are deposited on the canyon floor and from there are pushed against the canyon face at a slope of 2:1. In this way a high degree of compaction can be achieved. Control of surface drainage often is a critical factor. A key to the successful use of this

method is the availability of adequate material to cover the individual lift as they are completed and to provide the entire landfill when the final height is raised. Cover material is excavated from the canyon walls or floor before the liner system is installed. Borrow pits and abandoned quarries may not contain sufficient soil for intermediate cover so that cover material may have to be imported. Compost produced from yard waste and MSW can also be used for intermediate cover layers.

### **Gases and Leachate:**

**Composition, Characteristics, Generation And Movement Of Land Filled Gases. Composition:** Land fill gas is composed of number of gases that are present in large amounts (principal gases) and No. of gases present in small amounts (trace gases). The principal gases are produced by the decomposition of MSW. Some of the trace although present in small quantities may be toxic and could present risk to public health.

### **Principal Landfill Gas Constituents**

- Gases found in land fill includes NH<sub>3</sub>, CO<sub>2</sub>, CO, H<sub>2</sub>S, CH<sub>4</sub>, N<sub>2</sub>, H<sub>2</sub> and O<sub>2</sub>.
- CH<sub>4</sub> and CO<sub>2</sub> are the principle gases are the principal gases produced from anaerobic decomposition of biodegradable organic components in MSW.
- When CH<sub>4</sub> is present in air in concentration b/n 5- 15%. It is explosive because only limited amount of oxygen is present in a land fill when CH<sub>4</sub>concentration reach this critical level.
- There is little danger that the landfill will explode. However, CH<sub>4</sub> mixtures in explosive range can form if land fill gases migrates offsite and mixes with air.
- The concentration of these gases that may be expected in the leachate will depend on their concentration in the gas phase in contact with the leachate.

**Trace Landfill Gas Constituent:** In a study conducted in England, gas samples were collected from three different landfills and analyzed were 154 compounds. A total of 116 compounds were found in landfill gas, many compounds could be classified as volatile organic compounds ( VOC). The trace gases found in land fill

includes Acetone, Benzene, Chlorobenzene, Chloroform, Di-chloromethane, Ethylene bromide, Toluene, Tetrachloro-ethylene, Vinyl Acetate, Xylene, Vinyl chloride, etc The occurrence of significant concentration of VOC is associated with older landfills that accepted industrial and commercial waste containing VOC. In newer landfills in which the disposal of hazardous waste is banned, the concentration of VOC in landfill gas have been extremely low.

**Occurrences of Gases And Leachate In Landfills:** The following biological, physical and chemical events occur when solid wastes are placed in sanitary landfill.

i) Biological decay of organic materials either aerobically or anaerobically with evolution of gases and liquids.

ii) Chemical oxidation of waste materials

iii) Escape of gases from the landfill.

iv) Movements of gases caused by differential pressures

v) Dissolving and leaching of organic and inorganic materials by water and leachate moving through the landfills.

vi) Movement of dissolved materials from concentrated gradient and osmosis.

vii) Uneven settlement caused by Consolidation, Settlement Into Voids.

### Gas Movement

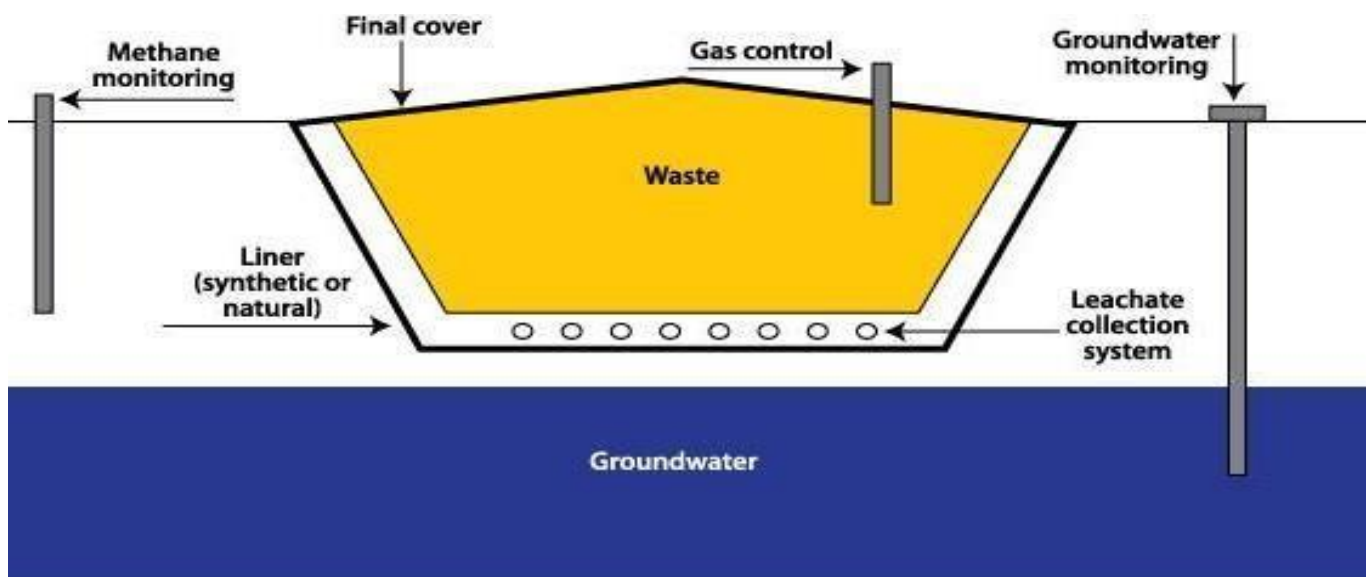

- Under ideal conditions, the gases generated from a landfill should be either vented to the atmosphere or in larger landfills collected for the production of energy.
- In most cases over 90% gas volume produced from decomposition of solid waste and of CH<sub>4</sub> and CO<sub>2</sub>.
- Although most of the CH<sub>4</sub> escapes to the atmosphere, both CH<sub>4</sub> and CO<sub>2</sub> have been found in concentration up to 40% at lateral distances of up to 130m at the edges of the landfill.
- If vented into the atmosphere in an uncontrolled manner CH<sub>4</sub> can accumulate (because its specific gravity is less than air) below the buildings or other enclosed spaces are closed to a sanitary landfill with proper venting, CH<sub>4</sub> should not be a problem.
- CO<sub>2</sub> is about 1.5 times as dense as air and 2.0 times as dense as CH<sub>4</sub>, it tends to move towards the bottom of the landfill.
- As a result, the concentration of CO<sub>2</sub> in the landfill may be high for years.
- Ultimately because of this density CO<sub>2</sub> will also move downwards through the underlying formation unit it reaches ground water.
- Because CO<sub>2</sub> is readily soluble in H<sub>2</sub>O, it usually lowers the PH value which in turn can increase hardness and mineral content of ground water through stabilization of calcium and magnesium carbonates.

**Control of Gas Movement:** The movement of gases in landfills can be controlled by constructing vents and barriers and by gas recovery.

**Control of Gas Movement with Vents and Barriers:** The lateral movement of gases produced in a land till can be controlled by starting name made of materials that are not permeable than the surrounding soil. Typically, as shown in figure, gas vents are constructed of gravel. The spacing of cell vents depends on the width of the waste cells but usually varies from (10-60m) (60-200ft). The thickness of the gravel layer should be such that it will remain continuous even though there may be differential setting over of gases. We events are often used in conjunction with apteral surface vents buried below grade in a gravel trench control of the downward movement of gases can be accomplished by installing perforated pipes in a gravel layer at the bottom of the landfill.

## Well Type

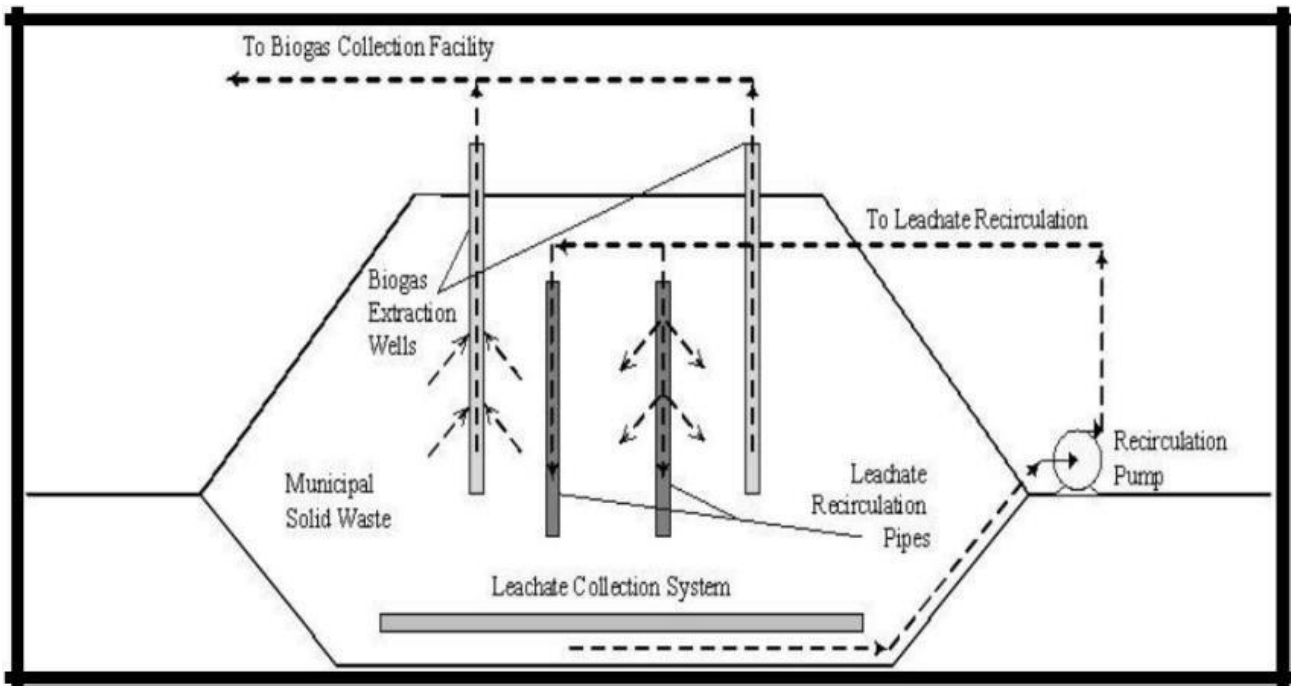

## Barrier Type Gas Control

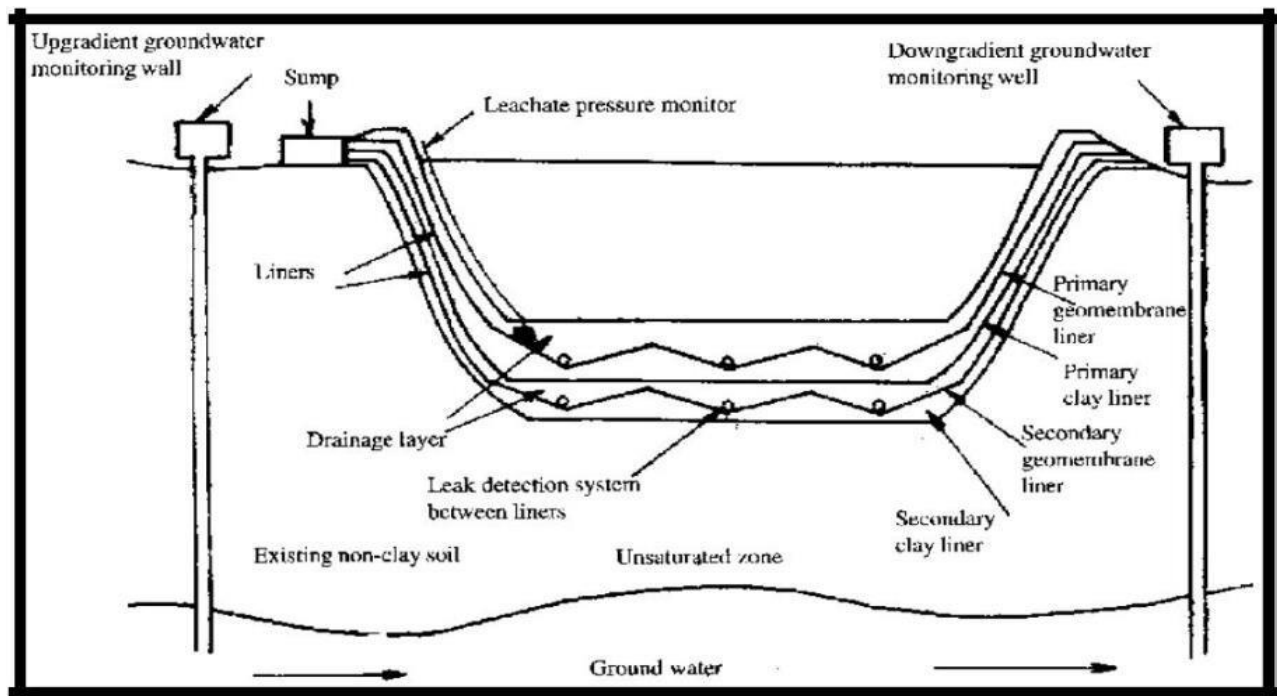

The movement of land fill gases through adjacent soil formations can be controlled by constructing barriers of materials that are more impermeable than the soil. Some of the landfill sealants that are available for this use are betonites, illites, kaolinites, sodium carbonate, silicate, pyrophosphate, polymers, rubber latex, etc. out of these, the compacted clays is most common. The thickness will vary depending on the type of clay and the degree of control required, thicknesses ranging from 0.15 to 1.25m (6-48 inches) have been used.

### **Control of Gas Movement by Recovery:**

The movement of gases in landfills can also be controlled by installing gas recovery wells in complete landfills clay and other liners are used where landfill gas is to be recovered. In some gas recovery systems, leachate is collected and recycled to the top of the landfill and injected through perforated lines located in drainage trenches. Typically, the rate of gas production is greater in leachate recirculation systems or where water is added. Although gas recovery systems have been installed in some large municipal landfills, the economics of such operations are at present, not well defined. The cost of the gas cleans up.

### **Leachate Composition, Formation, Movement and Control of Leachate In Landfill**

May be defined as liquid that has percolated through solid waste and has extracted dissolved and suspended materials and is composed of the liquid that has entered the landfill from external sources such as surface drainage, rainfall, ground water and water from underground springs and liquid produced from decomposition of solid waste.

#### **Composition of Leachate.**

- When water percolates through S.W. that are undergoing decomposition both biological materials and chemical constituents are least into the solution.
- The chemical composition of leachate will vary greatly depending upon the age of the land fill and events preceding the type of sample.

- If a leachate sample is collated during acid phase of decomposition PH value will be very high.
- On the other hand, leachate sample that is collated during methane fermentation phase, the PH value will be in the range of 6.5-7.5 and BOD, COD, TOC and Nutrient values will be lower.
- Similarly, concentration of heavy metals will be lower because most metals are less soluble at Neutral PH values of the leachate and will depend not only on the concentration of acids that are present but also on partial pressure of CO<sub>2</sub> in landfill gas that is in contact with leachate.
- The bio degradability of leachate will vary with time changes in biodegradability can be monitored by checking BOD<sub>5</sub> and COD ratios will be in the range of 0.5 or greater, ratios in the range of 0.4- 0.6 are taken as indicators that the organic material is readily degradable (1:1.6 to 2.6) In matured landfills this ratio is often in the range 0.05 to 0.2, the ratio drops because the leachate from matured landfills typically contains humic and pelvic acids, which are readily not bio-degradable.
- As a result of variability in leachate characteristics, the design of leachate treatment facilities is complicated.
- Usually the treatment of the leachate will be taken care of domestic waste water treatment plants.

### **Leachate Movement:**

- Under normal conditions, leachate is found in the bottom of landfills. From there, its movement is through the underlying strata, although some lateral movement may also occur, depending on the characteristics of the surrounding material.
- The rate of seepage of leachate from the bottom of a landfill can be estimated by Darcy's law by assuming that the material below the landfill to the top of the water table is saturated and that a small layer of leachate exists at the bottom of the fill.
- Under these conditions the leachate discharge rate per unit area is equal to the value of the co-efficient of permeability 'K' expressed in meters per day.

- The computed value represents the medium amount of seepage to be used for design purposes. Under normal conditions, the actual rate would be less than this value because the soil column below the landfill would not be saturated.

### **Control of Leachate Movement:**

- As leachate percolates through the underlying strata, many of the chemical and biological constituents originally contained in it will be removed by the filtering and adsorptive action of the material composing the strata.
- In general, the extent of this action depends on the characteristics of the soil, especially the clay content. Because of the potential risk involved in allowing leachate to percolate to the ground water, best practice calls for its elimination or containment.
- Ultimately, it may be necessary to collect and treat the leachate. The use of clay has been the favored method of reducing or eliminating the percolation of leachate.
- Membrane liners have also been used, but they are expensive and require care so that they will not be damaged during the filling operations.
- Equally important in controlling the movement of leachate is the elimination of surface water infiltration, which is the major contributor to the total volume of leachate. With the use of an impermeable clay layer, and appropriate surface slope (1 to 2 percent) and adequate drainage, surface infiltration can be controlled effectively.
- Generalized ratings for the suitability of various types of soil for use as a landfill cover.

**Leachate Treatment:** Here leachate recycling and evaporation is not used and direct disposal of leachate to a treatment facility is not possible and some form of pre-treatment or complete treatment will be required. Because the characterization of collected leachate will vary so widely a number of options have been used for treatment of leachate.

**The Principal Biological and physical/ chemical treatment operation.**

<b>TREATMENT PROCESS</b>	<b>APPLICATION</b>
Biological Processes	Removal of organics
Activated sludge process	Removal of organics
Crated stabilization tank	- “ -
Trickling filters and rotating biological contactors	- “ -
Anaerobic lagoon	- “ -
Nitrification and denitrification	- “ -
<b>B. CHEMICAL PROCESSES</b>	
i. Neutralization	PH control
ii. Chemical precipitation	Removal of metals
iii. Chemical oxidation	Removal of organics and removal of organic substances
iv. Wet air oxidation	Removal of organics
<b>C. PHYSICAL PROCESSES</b>	
i. Sedimentation/ Floatation	Removal of suspended matter
ii. Filtration	- “ -

iii. Air stripping	Removal of Ammonia or volatile organic matter
iv. Steam stripping	Removal of volatile Organic Matter

### **Selection of Treatment Facilities:**

The type of treatment facilities used depends primarily on the characteristics of leachate and secondary in geographic and physical location of land fill. Leachate characteristics are including total dissolved solids (TDS), COD, sulphate heavy metals, toxic constituents. Leachate containing extremely high concentration of inorganic matters may be difficult to treat high COD values favors anaerobic treatment because aerobic treatment is quite expensive high sulphate concentration may limit anaerobic treatment and heavy metal toxicity is also a problem with many biological treatment processes.

### **PROBLEM:**

1. Determine landfill area required for a municipality with a population

50,000 given that

i) Solid waste generation = 350 gms/ person/day

ii) Compacted density of landfill = 504 Kg/m<sup>3</sup>

iv) Average depth of compacted S.W = 3

### **SOLUTION:**

Calculation of total amount of S.W. generation in a day:

Total amount of S.W generated = population x per capita.

S.W in a degeneration

$$= 50000 \times 350$$

$$= 17.5 \times 10^3 \text{ Kg/day}$$

II. Calculation of volume of S.W:

Volume of S. W = V = Total amount of S.W

$$\text{Compacted density} = 17500 \text{ K/g} \cdot \text{m}^3 \cdot 0.504 \text{ K/g} \cdot \text{m}^3. \underline{V = 34.72 \text{ m}^3 / \text{day}}$$

### **Development of Longterm Closure Plan:**

The most important element in the long term maintenance (30-50 years) of a completed landfill is the availability of closure plan in which the requirements for the closure are defined clearly a closure plan must include a design for the landfill cover and landscaping of the completed site. Closure must also include long term plans for the control of run off, erosion, control, gas and leachate collection and treatment and environmental monitoring.

### **Post Closure Care:**

It involves the routine inspection of the completed landfill site, maintenance of the infrastructure and environmental monitoring. Leachate is a widely used term in the environmental sciences where it has the specific meaning of a liquid that has dissolved or entrained environmentally harmful substances that may then enter the environment. It is most commonly used in the context of land-filling of putrescible or industrial waste. In the narrow environmental context leachate is therefore any liquid material that drains from land or stockpiled material and contains significantly elevated concentrations of undesirable material derived from the material that it has passed through.

## Landfill Leachate



- Leachate from a landfill varies widely in composition depending on the age of the landfill and the type of waste that it contains.
- It usually contains both dissolved and suspended material. The generation of leachate is caused principally by precipitation percolating through waste deposited in a landfill.
- Once in contact with decomposing solid waste, the percolating water becomes contaminated, and if it then flows out of the waste material it is termed leachate.
- Additional leachate volume is produced during this decomposition of carbonaceous material producing a wide range of other materials including methane, carbon dioxide and a complex mixture of organic acids, aldehydes, alcohols and simple sugars.
- The risks of leachate generation can be mitigated by properly designed and engineered landfill sites, such as those that are constructed on geologically impermeable materials or sites that use impermeable liners made of geo membranes or engineered clay.
- The use of linings is now mandatory within the United States, Australia and the European Union except where the waste is deemed inert. In addition, most toxic and difficult materials are now specifically excluded from landfilling.
- However, despite much stricter statutory controls, leachates from modern sites are often found to contain a range of contaminants stemming from illegal activity or legally discarded household and domestic products

## **Composition of landfill leachate**

- When water percolates through waste, it promotes and assists the process of decomposition by bacteria and fungi.
- These processes in turn release by-products of decomposition and rapidly use up any available oxygen, creating an anoxic environment.
- In actively decomposing waste, the temperature rises and the pH falls rapidly with the result that many metal ions that are relatively insoluble at neutral pH become dissolved in the developing leachate.
- The decomposition processes themselves release more water, which adds to the volume of leachate. Leachate also reacts with materials that are not prone to decomposition themselves, such as fire ash, cement-based building materials and gypsum-based materials changing the chemical composition.
- In sites with large volumes of building waste, especially those containing gypsum plaster, the reaction of leachate with the gypsum can generate large volumes of hydrogen sulphide, which may be released in the leachate and may also form a large component of the landfill gas. In a landfill that receives a mixture of municipal, commercial, and mixed industrial waste but excludes significant amounts of concentrated chemical waste, landfill leachate may be characterized as a water-based solution of four groups of contaminants: dissolved organic matter (alcohols, acids, aldehydes, short chain sugars etc.), inorganic macro components (common cations and anions including sulfate, chloride, iron, aluminum, zinc and ammonia), heavy metals (Pb, Ni, Cu, Hg), and xenobiotic organic compounds such as halogenated organics, (PCBs, dioxins, etc.).
- The physical appearance of leachate when it emerges from a typical landfill site is a strongly odorous, black, yellow or orange-colored cloudy liquid.
- The smell is acidic and offensive and may be very pervasive because of hydrogen-, nitrogen- and sulfur-rich organic species such as mercaptans.

## **Leachate Management**

In older landfills and those with no membrane between the waste and the underlying geology, leachate is free to leave the waste and flow directly into the groundwater. In such cases, high concentrations of leachate are often found in nearby springs and flushes. As leachate first emerges it can be black in color, anoxic, and possibly effervescent, with dissolved and entrained gases. As it becomes oxygenated it tends to turn brown or yellow because of the presence of iron salts in solution and in suspension. It also quickly develops a bacterial flora often comprising substantial growths of *Sphaerotilus natans*.

## **History of landfill leachate collection**

In the UK, in the late 1960s, central Government policy was to ensure new landfill sites were being chosen with permeable underlying geological strata to avoid the build-up of leachate. This policy was dubbed "dilute and disperse". However, following a number of cases where this policy was seen to be failing, and an expose in The Sunday Times of serious environmental damage being caused by inappropriate disposal of industrial wastes, both policy and the law were changed. The deposit of poisonous wastes act 1972, together with the 1974 local government act, made local government responsible for waste disposal and for the enforcement of environmental standards regarding waste disposal. Proposed landfill locations also had to be justified not only by geography but also scientifically. Many European countries decided to select landfill sites in groundwater-free clay geological conditions or to require that the site have an engineered lining. In the wake of European advancements, the United States increased its development of leachate retaining and collection systems. This quickly led from lining in principle to the use of multiple lining layers in all landfills (excepting those truly inert).



## **Components of Leachate Collection Systems**

There are many components to a collection system including pumps, manholes, discharge lines and liquid level monitors. However, there are four main components which govern the overall efficiency of the system. These four elements are liners, filters, pumps and sumps.

### **Liners**

- Natural and synthetic liners may be utilized as both a collection device and as a means for isolating leachate within the fill to protect the soil and groundwater below.
- The chief concern is the ability of a liner to maintain integrity and impermeability over the life of the landfill.
- Subsurface water monitoring, leachate collection, and clay liners are commonly included in the design and construction of a waste landfill.
- To effectively serve the purpose of containing leachate in a landfill, a liner system must possess a number of physical properties.
- The liner must have high tensile strength, flexibility, and elongation without failure. It is also important that the liner resist abrasion, puncture, and chemical degradation by leachate.
- Lastly, the liner must withstand temperature variation and be black (to resist UV light), easily installed, and economical.
- There are several types of liners used in leachate control and collection. These types include geo membranes, geo synthetic clay liners, geotextiles, geo grids, geo nets, and geo composites.
- Each style of liner has specific uses and abilities. Geo membranes are used to provide a barrier between mobile polluting substances released from wastes and the groundwater.
- In the closing of landfills, geo membranes are used to provide a lowpermeability cover barrier to prevent the intrusion of rain water.
- Geo synthetic clay liners (GCLs) are fabricated by distributing sodium bentonite in a uniform thickness between woven and non-woven geotextiles. Sodium bentonite has a low permeability, which makes GCLs a suitable alternative to clay liners in a composite liner system. Geotextiles are used as

separation between two different types of soils to prevent contamination of the lower layer by the upper layer.

- Geotextiles also act as a cushion to protect synthetic layers against puncture from underlying and overlying rocks.
- Geogrids are structural synthetic materials used in slope veneer stability to create stability for cover soils over synthetic liners or as soil reinforcement in steep slopes.
- Geonets are synthetic drainage materials that are often used in lieu of sand and gravel.
- Radz can take 12 in (30 cm) of drainage sand, thus increasing the landfill space for waste. Geo composites are a combination of synthetic materials that are ordinarily used singly geocomposite is a geonet that is heat-bonded to two layers of geotextile, one on each side.

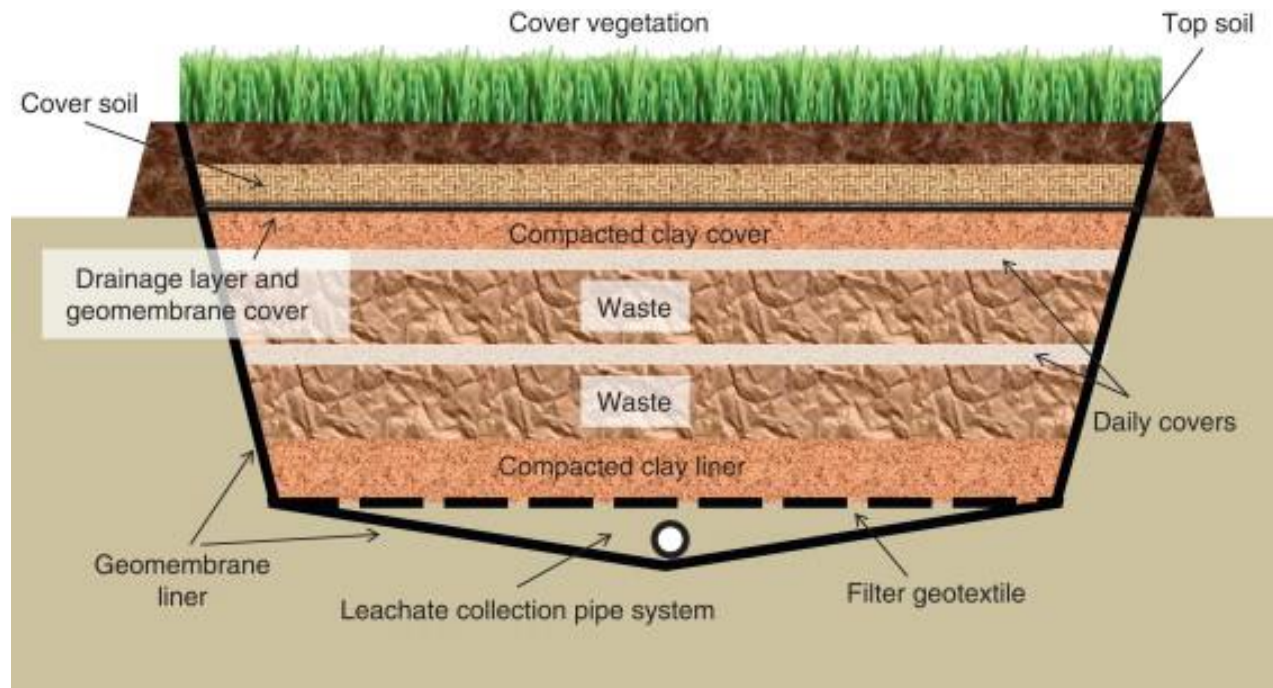

## Leachate drainage system



- The leachate drainage system is responsible for the collection and transport of the leachate collected inside the liner.
- The pipe dimensions, type, and layout must all be planned with the weight and pressure of waste, and transport vehicles in mind.
- The pipes are located on the floor of the cell. Above the network lies an enormous amount of weight and pressure.
- To support this, the pipes can either be flexible or rigid, but the joints to connect the pipes yield better results if the connections are flexible.
- An alternative to placing the collection system underneath the waste is to position the conduits in trenches or above grade.
- The collection pipe network of a leachate collection system drains, collects, and transports leachate through the drainage layer to a collection sump where it is removed for treatment or disposal.
- The pipes also serve as drains within the drainage layer to minimize the mounding of leachate in the layer.
- These pipes are designed with cuts that are inclined to 120 degrees, preventing entry of solid particles.

## Filter

The filter layer is used above the drainage layer in leachate collection. There are two types of filters typically used in engineering practices: granular and geotextile. Granular filters consist of one or more soil layers or multiple layers having a coarser gradation in the direction of the seepage than the soil to be protected.

## Sumps or leachate well

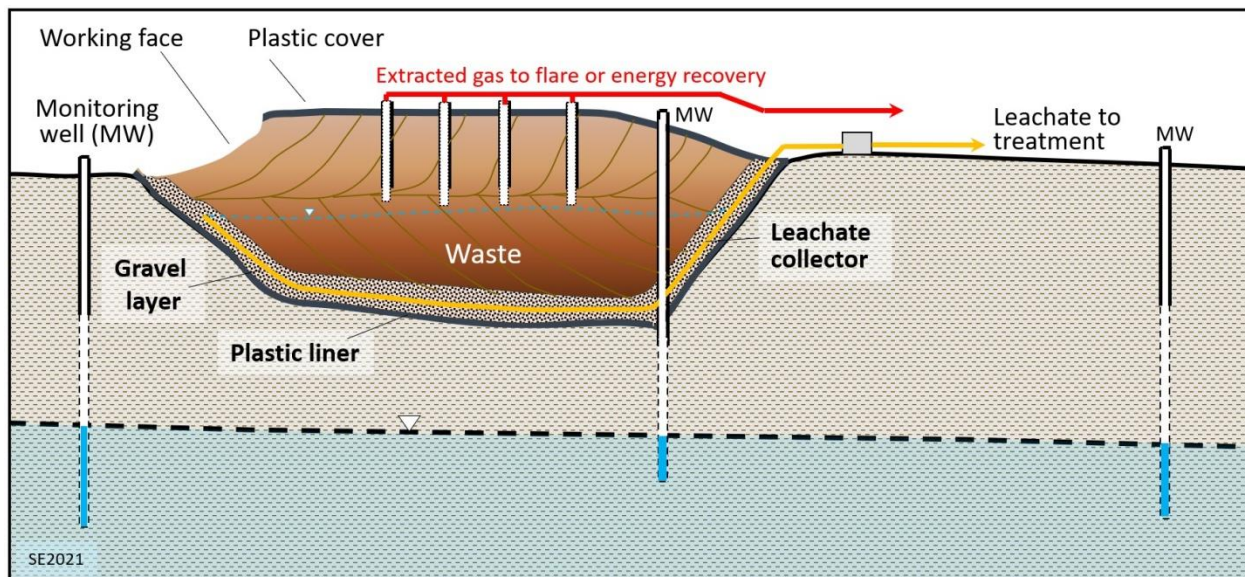

- As liquid enters the landfill cell, it moves down the filter, passes through the pipe network, and rests in the sump.
- As collection systems are planned, the number, location, and size of the sumps are vital to an efficient operation.
- When designing sumps, the amount of leachate and liquid expected is the foremost concern.
- Areas in which rainfall is higher than average typically have larger sumps.
- A further criterion for sump planning is accounting for the pump capacity.
- The relationship of pump capacity and sump size is inverse.
- If the pump capacity is low, the volume of the sump should be larger than average.
- It is critical for the volume of the sump to be able to store the expected leachate between pumping cycles.

- This relationship helps maintain a healthy operation.
- Sump pumps can function with preset phase times.
- If the flow is not predictable, a predetermined leachate height level can automatically switch the system on.
- Other conditions for sump planning are maintenance and pump drawdown.
- Collection pipes typically convey the leachate by gravity to one or more sumps, depending upon the size of the area drained.
- Leachate collected in the sump is removed by pumping to a vehicle, to a holding facility for subsequent vehicle pickup, or to an on-site treatment facility.
- Sump dimensions are governed by the amount of leachate to be stored, pump capacity, and minimum pump drawdown.
- The volume of the sump must be sufficient to hold the maximum amount of leachate anticipated between pump cycles, plus an additional volume equal to the minimum pump drawdown volume.

## **MODULE-4**

### **Membrane and collection for treatment**

- More modern landfills in the developed world have some form of membrane separating the waste from the surrounding ground, and in such sites there is often a leachate collection series of pipes laid on the membrane to convey the leachate to a collection or treatment location.
- An example of a treatment system with only minor membrane use is the Nantmel Landfill Site.
- All membranes are porous to a limited extent so that, over time, low volumes of leachate will cross the membrane.
- The design of landfill membranes is at such low volumes that they should never have a measurable adverse impact on the quality of the receiving groundwater.
- A more significant risk may be the failure or abandonment of the leachate collection system.
- Such systems are prone to internal failure as landfills suffer large internal movements as waste decomposes unevenly and thus buckles and distorts pipes.
- If a leachate collection system fails, leachate levels will slowly build in a site and may even over-top the containing membrane and flow out into the environment.
- Rising leachate levels can also wet waste masses that have previously been dry, triggering further active decomposition and leachate generation.
- Thus, what appears to be a stabilized and inactive site can become re-activated and restart significant gas production and exhibit significant changes in finished ground levels.

## Re-injection into landfill

One method of leachate management that was more common in uncontained sites was leachate re-circulation, in which leachate was collected and re-injected into the waste mass. This process greatly accelerated decomposition and therefore gas production and had the impact of converting some leachate volume into landfill gas and reducing the overall volume of leachate for disposal. However, it also tended to increase substantially the concentrations of contaminant materials, making it a more difficult waste to treat.

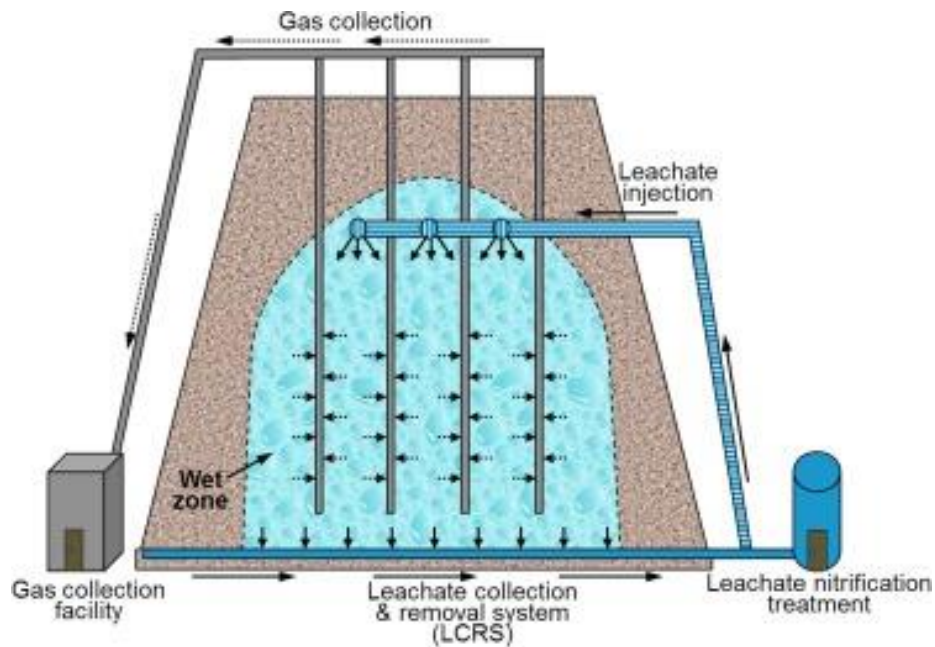

## Treatment

- Leachate processing / equalization tanks used in leachate treatment before releasing to a river.
- The most common method of handling collected leachate is on-site treatment.
- When treating leachate on-site, the leachate is pumped from the sump into the treatment tanks.
- The leachate may then be mixed with chemical reagents to modify the pH and to coagulate and settle solids and to reduce the concentration of hazardous matter.

- Traditional treatment involved a modified form of activated sludge to substantially reduce the dissolved organic content.
- Nutrient imbalance can cause difficulties in maintaining an effective biological treatment stage.
- The treated liquor is rarely of sufficient quality to be released to the environment and may be tankered or piped to a local sewage treatment facility; the decision depends on the age of the landfill and on the limit of water quality that must be achieved after treatment.
- With high conductivity, leachate is hard to treat with biological treatment or chemical treatment.
- Treatment with reverse osmosis is also limited, resulting in low recoveries and fouling of the RO membranes.
- Reverse osmosis applicability is limited by conductivity, organics, and scaling inorganic elements such as CaSO<sub>4</sub>, Si, and Ba.
- USA EPA monthly average discharge limits for surface discharge of landfill leachate and typical leachate characteristics.
- Typical landfill leachate treatment options and tips for different leachate types.

### **Removal to sewer system**

- In some older landfills, leachate was directed to the sewers, but this can cause a number of problems.
- Toxic metals from leachate passing through the sewage treatment plant concentrate in the sewage sludge, making it difficult or dangerous to dispose of the sludge without incurring a risk to the environment.
- In Europe, regulations and controls have improved in recent decades, and toxic wastes are now no longer permitted to be disposed of in the Municipal Solid
- Waste landfills, and in most developed countries the metals problem has diminished. Paradoxically, however, as sewage treatment plant discharges are being improved throughout Europe and many other countries, the plant operators are finding that leachates are difficult waste streams to treat.
- This is because leachates contain very high ammonia nitrogen concentrations, are usually very acidic, are often anoxic and, if received in large volumes

relative to the incoming sewage flow, lack the Phosphorus needed to prevent nutrient starvation for the biological communities that perform the sewage treatment processes.

- The result is that leachates are a difficult-to-treat waste stream.
- However, within aging municipal solid waste landfills, this may not be a problem as the pH returns close to neutral after the initial stage of acid genic leachate decomposition.

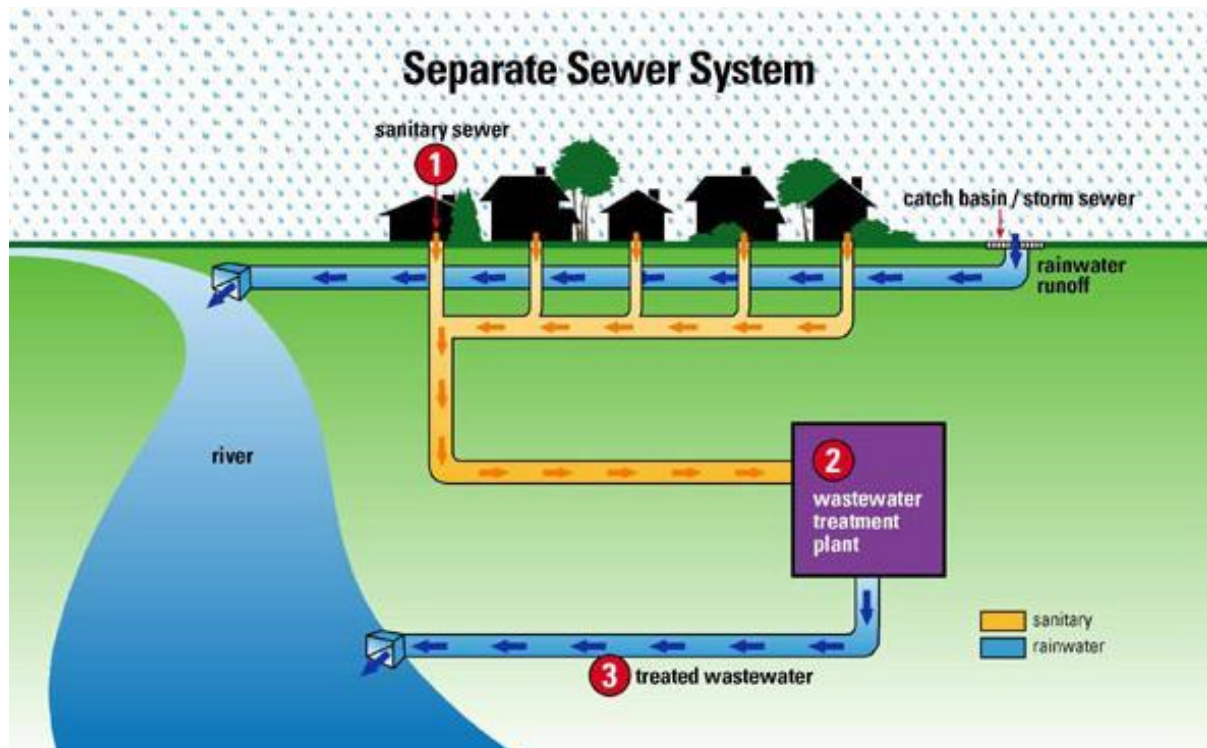

### Environmental impact

- The risks from waste leachate are due to its high organic contaminant concentrations and high concentration of ammonia.
- Pathogenic microorganisms that might be present in it are often cited as the most important, but pathogenic organism counts reduce rapidly with time in the landfill, so this only applies to the freshest leachate.
- Toxic substances may, however, be present in variable concentrations, and their presence is related to the nature of the waste deposited.

- Most landfills containing organic material will produce methane, some of which dissolves in the leachate.
- This could, in theory, be released in poorly ventilated areas in the treatment plant. All plants in Europe must now be assessed under the EU ATEX directive and zoned where explosion risks are identified to prevent future accidents.
- The most important requirement is the prevention of the discharge of dissolved methane from untreated leachate into public sewers, and most sewage treatment authorities limit the permissible discharge concentration of dissolved methane to 0.14 mg/l, or 1/10 of the lower explosive limit.
- This entails methane stripping from the leachate.
- The greatest environmental risks occur in the discharges from older sites constructed before modern engineering standards became mandatory and also from sites in the developing world where modern standards have not been applied.
- There are also substantial risks from illegal sites and ad-hoc sites used by organizations outside the law to dispose of waste materials.
- Leachate streams running directly into the aquatic environment have both an acute and chronic impact on the environment, which may be very severe and can severely diminish bio-diversity and greatly reduce populations of sensitive species.
- Where toxic metals and organics are present this can lead to chronic toxin accumulation in both local and far distant populations.
- Rivers impacted by leachate are often yellow in appearance and often support severe overgrowths of sewage fungus.
- The contemporary research in the field of assessment techniques and remedial technology of environmental issues originating from landfill leachate has been reviewed in an article published in Critical Reviews in Environmental Science and Technology journal.

## Problems and failures with collection systems

- Leachate collection systems can experience many problems including clogging with mud or silt.
- Bio clogging can be exacerbated by the growth of micro organisms in the conduit.
- The conditions in leachate collection systems are ideal for micro-organisms to multiply.
- Chemical reactions in the leachate may also cause clogging through generation of solid residues.
- The chemical composition of leachate can weaken pipe walls, which may then fail.
- Other types of leachate Leachate can also be produced from land that was contaminated by chemicals or toxic materials used in industrial activities such as factories, mines or storage sites.
- Composting sites in areas of high rainfall also produce leachate.
- Leachate is also associated with stockpiled coal and with waste materials from metal ore mining and other rock extraction processes, especially those in which sulfide containing materials are exposed to air producing sulfuric acid, often with elevated metal concentrations.
- In the context of civil engineering (more specifically reinforced concrete design), leachate refers to the effluent of pavement wash-off (that may include melting snow and ice with salt) that permeates through the cement paste onto the surface of the steel reinforcement, thereby catalyzing its oxidation and degradation.
- Leachates can be genotoxic in nature

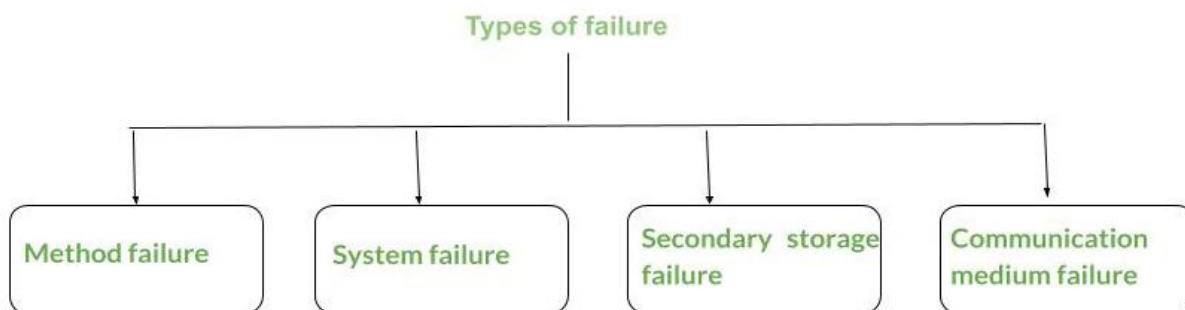

## **Sources, Collection, Treatment and Disposal Of:**

- 1) Biomedical Waste
- 2) E-Waste
- 3) Hazardous Waste
- 4) Construction Waste Biomedical Waste.

### **Sources of Biomedical Waste**

- Hospitals
- Emergency care facilities
- Outpatient facilities, dialysis centers, prisons, transfusion centers, laboratories
- Mortuaries, death care companies
- Blood banks
- Nursing homes
- Doctors and dentist's offices
- Chiropractors
- Ambulance companies
- Needle exchanges

# Collection of BMW:

❑ Segregated collection of waste *at source* is a single most important step in bio-medical waste management and this practice results in-

- ✓ Waste minimization
- ✓ Effective waste management
- ✓ Decrease in expenses incurred in managing waste
- ✓ Reduce the risk of infection ensuring better healthcare

❑ Bio-Medical Waste Management Rules 1998 gives the colour coding that should be used for the various categories of waste-

## APPROACH FOR **biomedical** WASTE MANAGEMENT

### 1. Segregation of waste

Segregation is the essence of waste management and should be done at the source of generation of Bio-medical waste e.g. all patient care activity areas, diagnostic services areas, operation theaters, labour rooms, treatment rooms etc. The responsibility of segregation should be with the generator of biomedical waste i.e. doctors, nurses, technicians etc. (medical and paramedical personnel).

### 2. Collection of bio-medical waste

Collection of bio-medical waste should be done as per Bio-medical waste (Management and Handling) Rules. At ordinary room temperature the collected waste should not be stored for more than 24 hours.

### 3. Transportation

Within hospital, waste routes must be designated to avoid the passage of waste through patient care areas. Separate time should be earmarked for transportation of bio-medical waste to reduce chances of it's mixing with general waste. Desiccated wheeled containers, trolleys or carts should be used to transport the waste/plastic bags to the site of storage/ treatment.

### 4. Treatment of hospital waste

#### 4.1 General waste

The 85% of the waste generated in the hospital belongs to this category. The safe disposal of this waste is the responsibility of the local authority.

**IMAGE**  
**Bio-Medical Waste Segregation Chart**

Category	Type of Waste
<b>YELLOW</b> 	<ul style="list-style-type: none"> <li>• Post Operative Body Parts</li> <li>• Placenta</li> <li>• Plaster of Paris (POP)</li> <li>• Pathological Waste</li> <li>• Cotton Waste</li> <li>• Dressing Materials</li> <li>• Beddings</li> <li>• Body Fluid Contaminated Paper and Cloth</li> <li>• Face Mask, Cap</li> <li>• Cytotoxic, Expired &amp; Discarded Medicines</li> <li>• Microbiology, Biotechnology Lab Waste</li> </ul>
<b>RED</b> 	<ul style="list-style-type: none"> <li>• Syringe with out needles</li> <li>• I.V.Set</li> <li>• Catheters</li> <li>• Gloves</li> <li>• Urine Bag</li> <li>• Dialysis Kit</li> <li>• IV Bottles</li> </ul>
<b>WHITE (Translucent)</b> 	<ul style="list-style-type: none"> <li>• Needles</li> <li>• Syringes with fixed needles</li> <li>• Blades</li> <li>• Scalpels</li> <li>- Use 1% Hypo Chloride solution for disinfecting Glass &amp; Metal Sharps</li> </ul>
<b>BLUE</b> 	<ul style="list-style-type: none"> <li>• Glass               <ul style="list-style-type: none"> <li>- Broken Glass</li> <li>- Ampoules</li> <li>- Lab Slides</li> </ul> </li> <li>• Metals               <ul style="list-style-type: none"> <li>- Nails</li> <li>- Metallic Body Implants</li> <li>- Scissors</li> </ul> </li> <li>- Use 1% Hypo Chloride Solution for disinfecting Glass &amp; Metal Sharps</li> </ul>



## Treatment of Biomedical Waste

There are mainly five technology options available for the treatment of biomedical waste. They can be grouped as follows.

- Chemical processes
- Thermal processes
- Mechanical processes
- Irradiation processes
- Biological processes
- Chemical processes

These processes use chemicals that act as disinfectants. Sodium hypochlorite, dissolved chlorine dioxide, per acetic acid, hydrogen peroxide, dry inorganic chemical and ozone are examples of such chemicals. Most chemical processes are water-intensive and require neutralizing agents. Thermal processes These processes utilize heat to disinfect. Depending on the temperature they operate, it is being grouped into two categories, which are Low-heat systems and High-heat

systems Low-heat systems (operates between 93 -177oC) use steam, hot water, or electromagnetic radiation to heat and decontaminate the waste. Autoclave & Microwave are low heat systems

i. Autoclaving is a low heat thermal process and it uses steam for disinfection of waste. Autoclaves are of two types depending on the method they use for removal of air pockets. They are gravity flow autoclave and vacuum autoclave.

ii. Microwaving is a process which disinfects the waste by moist heat and steam generated by microwave energy.

iii. High-heat systems employ combustion and high temperature plasma to decontaminate and destroy the waste. Incinerator & Hydroclaving are high heat systems.

### **Mechanical processes**



These processes are used to change the physical form or characteristics of the waste either to facilitate waste handling or to process the waste in conjunction with other treatment steps. The two primary mechanical processes are Compaction - used to reduce the volume of the waste. Shredding - used to destroy plastic and paper waste to prevent their reuse. Only the disinfected waste can be used in a

shredder. Irradiation processes In these processes, wastes are exposed to ultraviolet or ionizing radiation in an enclosed chamber. These systems require post shredding to render the waste unrecognizable.

### **Biological processes**

Biological enzymes are used for treating medical waste. It is claimed that biological reactions will not only decontaminate the waste but also cause the destruction of all the organic constituents so that only plastics, glass, and other inert will remain in the residues. Points to ponder in processing the waste  
Incineration

- Incinerators should be suitably designed to achieve the emission limits.
- Wastes to be incinerated shall not be chemically treated with any chlorinated disinfectants.
- Toxic metals in the incineration ash shall be limited within the regulatory quantities.
- Only low sulphur fuel like diesel shall be used as fuel in the incinerator.

#### Autoclaving

- The autoclave should be dedicated for the purpose of disinfecting and treating biomedical waste.
- When operating a gravity flow autoclave, medical waste shall be subjected to:
  - A temperature of not less than 121o and pressure of about 15 pounds per square inch (psi) for an autoclave residence time of not less than 60 minutes
  - A temperature of not less than 135 oC and a pressure of 31 psi for an autoclave residence time of not less than 45 minutes
  - A temperature of not less than 149 oC and a pressure of 52 psi for an autoclave residence time of not less than 30 minutes.
- When operating a vacuum autoclave, medical waste shall be subjected to a minimum of one per vacuum pulse to purge the autoclave of all air. The waste shall be subjected to the following:
  - A temperature of not less than 121oC and a pressure of 15 psi per an autoclave residence time of not less than 45 minutes
  - temperature of not less than 135 oC and a pressure of 31 psi for an autoclave residence time of not less than 30 minutes.

## Microwaving



- Microwave treatment shall not be used for cytotoxic, hazardous or radioactive wastes, contaminated animal carcasses, body parts and large metal items.
- The microwave system shall comply with the efficacy tests/routine tests
- The microwave should completely and consistently kill bacteria and other pathogenic organism that is ensured by the approved biological indicator at the maximum design capacity of each microwave unit. Deep Burial
- A pit or trench should be dug about 2 m deep. It should be half filled with waste, and then covered with lime within 50 cm of the surface, before filling the rest of the pit with soil.
- It must be ensured that animals do not have access to burial sites.
- Covers of galvanized iron/wire meshes may be used.
- On each occasion, when wastes are added to the pit, a layer of 10cm of soil be added to cover the wastes.
- Burial must be performed under close and dedicated supervision.
- The site should be relatively impermeable and no shallow well should be close to the site
- The pits should be distant from habitation, and sited so as to ensure that no contamination occurs of any surface water or ground water.

- The area should not be prone to flooding or erosion.
- The location of the site will be authorized by the prescribed authority.
- The institution shall maintain a record of all pits for deep burial.

### **Disposal of sharp materials**

- Blades and needles waste after disinfection should be disposed in circular or rectangular pits.
- Such pits can be dug and lined with brick, masonry, or concrete rings.
- The pit should be covered with a heavy concrete slab, which is penetrated by a galvanized steel pipe projecting about 1.5 m above the slab, within internal diameter of up to 20 mm.
- When the pipe is full it can be sealed completely after another has been prepared.

### **Radioactive waste from medical establishments**

- It may be stored under carefully controlled conditions until the level of radioactivity is so low that they may be treated as other waste.
- Special care is needed when old equipment containing radioactive source is being discarded.
- Expert advice should be taken into account.

### **Mercury control**

- Wastes containing Mercury due to breakage of thermometer and other measuring equipment need to be given attention.
- Proper attention should be given to the collection of the spilled mercury, its storage and sending of the same back to the manufacturers.

- Must take all measures to ensure that the spilled mercury does not become part of biomedical wastes
- Waste containing equal to or more than 50 ppm of mercury is a hazardous waste and the concerned generators of the wastes including the health care units are required to dispose the waste as per the norms.

## **Waste minimization**

Waste minimization is an important first step in managing wastes safely, responsibly and in a cost effective manner. This management step makes use of reducing, reusing and recycling principles.

## **Stages of Medical Waste Disposal**

Where does medical waste go? How is medical waste disposed of? For purposes of this guide, we are going to focus on disposal in the US. Let's share with you the cautious and special care process in which medical waste is collected, stored, transported and treated with.

### **Stage 1 – Collecting & Segregating**

The biomedical waste has to be collected in containers that are resilient and strong from breakage during the handling process. Do not place sharps, used needles, syringes, or other contaminated tools in common waste disposal or recycle bin because the entire waste will be infectious by doing so. The segregation also needs to be performed between the liquid and solid biomedical waste products. Categorizing the medical waste with correct segregation to isolate and manage each waste in the proper way. For this purpose, the segregations come in colored waste containers, label coding and plastic bags.

### **Stage 2 – Storing & Transporting**

Specific requirements for storage facilities, such as a secure area that is inaccessible to the general public, as well as separated it from areas for food consumption. The storage facilities also have to be accompanied with refrigerator or freezer unit that can be used with medical waste if necessary. Some facilities even provided special vehicles and protective devices to dispose, handling or

transport the biomedical waste products. Remember to observe and keep maintaining the protective devices periodically so it won't be a source of transmitting the infections.

### **Stage 3 – Treatment**

The needs of professional handling that work according the by-law regulation such as the OSHA are needed to ensure that the regulated medical waste (RMW) is handled properly. The treatment process will use several medical waste equipment that ranged from handling, carts, shredding, conveying, size reducing, compactors, to sterilization or recycling. The following equipment is needed to properly process the waste in order to reduce the hazards, and maintain the environment.

- **Carts and containers** – commonly used to collect the medical waste i.e. dumpers, containers, compactors can be used to collect the medical waste.
- **Conveyors** – this equipment help to segregate the waste.
- **Sterilizers** – such as: autoclave, shredder, and size redactor.
- **Handling the waste** – such as: compactors, containers, pre-crushers, and DE liquefying system.
- **Recycling system** – i.e. balers and size reduction equipment

## Incineration

### Type 1 of Medical Waste Treatment

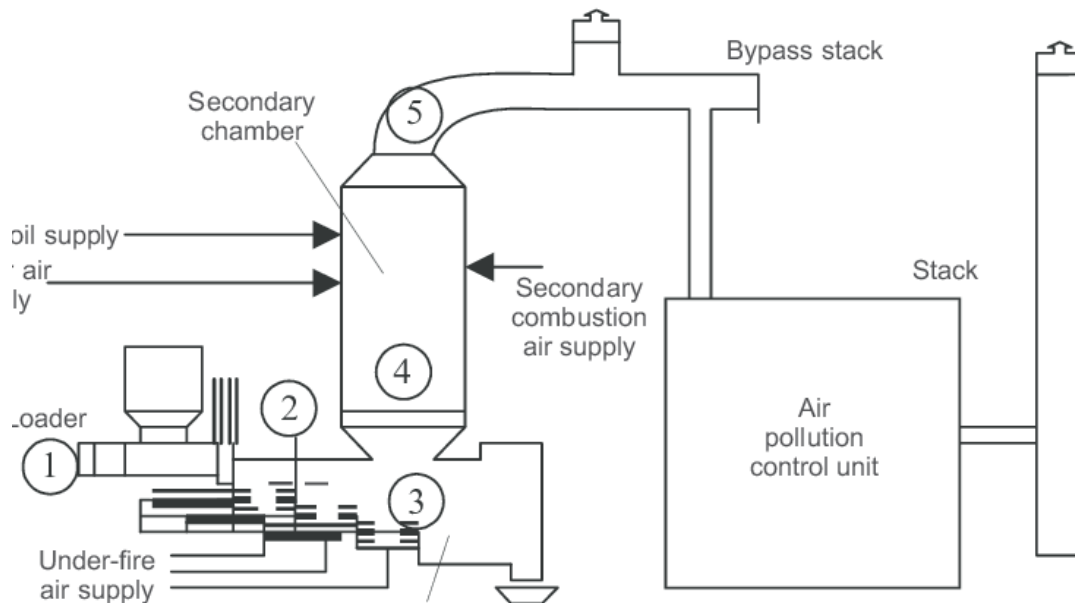

The incineration technology used a high temperature thermal process that can convert inert material and gases with the combustion process. It will process the waste to convert into ash, gas, and heat. There are three types of incinerators that are commonly used for biomedical waste:

1. The Multiple Hearth Type– it has a circular steel furnace that contains solid refractory hearths with a central rotating shaft to convert the waste into ash
2. Rotary Kiln – it is an incinerator, shape like a drum, commonly for medical and hazardous waste
3. Controlled Air – there are two process chambers that will handle the waste. The complete combustion and oxidizing it, leading to a stream of gas with carbon dioxide and water vapor composition. It is commonly used for waste that has organic materials. In addition, for some cases, performing a shredding for biomedical waste needed as an aid for incineration process.

## Non-Incineration System (Autoclaving, Irradiation, Chemical Methods)

### Type 2 of Medical Waste Treatment

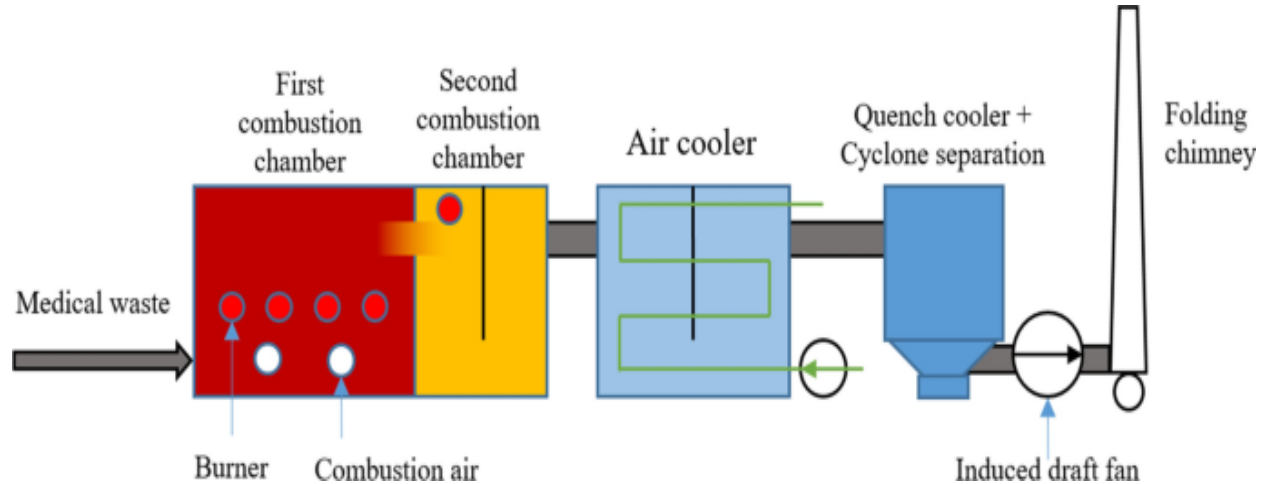

- A side from the incineration technology, the non-incineration method also provided to dispose the biomedical waste, it contains four basic processes such as thermal, irradiative, chemical, and biological.
- The autoclaving system (a photo of our autoclave machine is below) is commonly used for the human body fluid waste, sharps, and microbiology laboratory waste.
- This system requires high temperature (thermal) that produces steam to decontaminate the biomedical waste.
- The steam plays a critical role in the medical waste autoclaving process therefore a good waste holding container is required.
- While most of human body fluid waste can use this method, but the cytotoxic agents that used for chemotherapy cannot use this method due to those types of waste are not degraded with autoclave steams.
- Beside autoclaving, irradiation is the other thermal method which uses a high frequency microwave for disposal.
- The wave will generate heat to the waste materials and kill all the bacteria, or any other contamination in the tools.
- Another way of performing treatments for biomedical waste is chemical decontamination, this method can be used for microbiology laboratory waste,

human blood, sharps and body fluid waste, but cannot be used for treating anatomical waste.

- Aside from that, biological processes is a method that employ enzymes to destroy the organic matter of the waste, however there are very few non-incineration technologies have been based on this biological method.

### **On-Site and Off-Site Treatment of Medical Waste**

To differentiate which biomedical waste that can be performed on-site and off-site is important. Because in majority of the cases, the biomedical waste is a mixture and can be very difficult to manage it properly or even to segregate it, which is why an accurate simplified management of medical waste in segregating it according to the regulations will reduce the erroneous element. The on-site treatment usually requires expensive equipment. Not all facilities have this due to major infrastructure expenditure, but it is generally cost effective for very large hospitals and laboratories. Thus most medical waste producers choose off-site treatment known as regulated medical waste disposal companies because these companies have:

- The proper medical waste equipment
- Been state certified operating permits
- OSHA-trained personnel to collect transport or store the medical waste Once treated, the medical waste can be disposed of.
- In the US, for solid waste, once medical waste producers have adhered to regulations for collecting, storing, transporting, and treating their waste, they may then use their municipal landfill and sanitary sewer system as their final disposal method.
- That's right, your local municipal landfill is commonly used as the final place of your treated decontaminated biomedical waste.
- For fluids such as blood, suctioned fluids, excretions and secretions, almost every state and local government has its own regulations and guidelines to provide the best way to dispose it.
- In general, there are two recommended ways to handle medical waste fluids:
- Collect fluids in a leak proof container, and solidified for autoclave treatment

- Thermally (autoclave) fluids then they are disposed into the sanitary sewer system An extra precaution should be performed before pouring treated fluids in sewer because they may clog and leak.

### **Sources, Collection, Treatment And Disposal Of E-Waste:**

- Waste generated from the products used for data processing such as computers, computer devices like monitor, speakers, keyboards, printers etc.
- Electronic devices used for entertainment like TV, DVDs, and CD players.
- Equipment or devices used for communication like phones, landline phones, fax etc.
- Household equipment's like vacuum cleaner, microwave ovens, washing machines, air conditioners etc.
- Audio, visual components such as VCRs, Stereo equipment etc.
- Precious metal like gold, platinum, silver and palladium.
- Useful metals like copper, aluminum iron etc.
- Hazardous material like mercury, radioactive isotopes.
- Toxic substances like dioxins, polychlorinated biphenyls (PCBs).
- Plastic like High impact polystyrene (HIPS), Acrylonitrile butadiene styrene (ABS), Polycarbonate (PC), Polyphenylene oxide (PPO) etc.
- Glass material like cathode ray tube made of glasses such as SiO<sub>2</sub>, CaO, NaO.
- E- Waste consists of toxic metal like Hg, Pb, Cd. Cr which produces toxins.
- They are the sources of carcinogens like Polychlorinated biphenyls (PCBs), dioxins.
- They cause several health problems to all those who are directly involve with the e- waste processing, as they contain radioactive isotopes. E-waste" is a popular, informal name for electronic products nearing the end of their "useful life.
- "E-wastes are considered dangerous, as certain components of some electronic products contain materials that are hazardous, depending on their condition and density.
- The hazardous content of these materials pose a threat to human health and environment. Discarded computers, televisions, VCRs, stereos, copiers, fax machines, electric lamps, cell phones, audio equipment and batteries if

improperly disposed can leach lead and other substances into soil and groundwater.

- Many of these products can be reused, refurbished, or recycled in an environmentally sound manner so that they are less harmful to the ecosystem.
- This paper highlights the hazards of e-wastes, the need for its appropriate management and options that can be implemented. Industrial revolution followed by the advances in information technology during the last century has radically changed people's lifestyle.
- Although this development has helped the human race, mismanagement has led to new problems of contamination and pollution. The technical prowess acquired during the last century has posed a new challenge in the management of wastes.
- For example, personal computers (PCs) contain certain components, which are highly toxic, such as chlorinated and brominated substances, toxic gases, toxic metals, biologically active materials, acids, plastics and plastic additives.
- The hazardous content of these materials pose an environmental and health threat. Thus proper management is necessary while disposing or recycling E-wastes.
- These days computer has become most common and widely used gadget in all kinds of activities ranging from schools, residences, offices to manufacturing industries.
- E-toxic components in computers could be summarized as circuit boards containing heavy metals like lead & cadmium; batteries containing cadmium; cathode ray tubes with lead oxide & barium; brominated flame retardants used on printed circuit boards, cables and plastic casing; poly vinyl chloride (PVC) coated copper cables and plastic computer casings that release highly toxic dioxins & furans when burnt to recover valuable metals; mercury switches; mercury in flat screens; poly chlorinated biphenyl's (PCB's) present in older capacitors; transformers; etc.
- Basel Action Network (BAN) estimates that the 500 million computers in the world contain 2.87 billion kgs of plastics, 716.7 million kgs of lead and 286,700 kgs of mercury.

## Effects on Environment and Human Health by E-Waste

- Disposal of e-wastes is a particular problem faced in many regions across the globe.
- Computer wastes that are land filled produces contaminated leachates which eventually pollute the groundwater.
- Acids and sludge obtained from melting computer chips, if disposed on the ground causes acidification of soil.
- For example, Guiyu, Hong Kong a thriving area of illegal e-waste recycling is facing acute water shortages due to the contamination of water resources.
- This is due to disposal of recycling wastes such as acids, sludge etc. in rivers. Now water is being transported from faraway towns to cater to the demands of the population. Incineration of e-wastes can emit toxic fumes and gases, thereby polluting the surrounding air. Improperly monitored landfills can cause environmental hazards.
- Mercury will leach when certain electronic devices, such as circuit breakers are destroyed.
- The same is true for polychlorinated biphenyls (PCBs) from condensers.
- When brominated flame retardant plastic or cadmium containing plastics are landfilled, both polybrominated diphenyl ethers (PBDE) and cadmium may leach into the soil and groundwater.
- It has been found that significant amounts of lead ion are dissolved from broken lead containing glass, such as the cone glass of cathode ray tubes, gets mixed with acid waters and are a common occurrence in landfills.
- Not only does the leaching of mercury pose specific problems, the vaporization of metallic mercury and dimethylene mercury, both part of Waste Electrical and Electronic Equipment (WEEE) is also of concern.
- In addition, uncontrolled fires may arise at landfills and this could be a frequent occurrence in many countries.
- When exposed to fire, metals and other chemical substances, such as the extremely toxic dioxins and furans (TCDD tetrachloro dibenzo-dioxin, PCDDs polychlorinated dibenzodioxins. PBDDs-polybrominated dibenzo-dioxin and PCDFs-poly chlorinated dibenzo furans) from halogenated flame retardant products and PCB containing condensers can be emitted. The most

dangerous form of burning e-waste is the open- air burning of plastics in order to recover copper and other metals.

- The toxic fallout from open air burning affects both the local environment and broader global air currents, depositing highly toxic byproducts in many places throughout the world.
- Table I summarizes the health effects of certain constituents in e-wastes. If these electronic items are discarded with other household garbage, the toxics pose a threat to both health and vital components of the ecosystem.
- In view of the illeffects of hazardous wastes to both environment and health, several countries exhorted the need for a global agreement to address the problems and challenges posed by hazardous waste.
- Also, in the late 1980s, a tightening of environmental regulations in industrialized countries led to a dramatic rise in the cost of hazardous waste disposal. Searching for cheaper ways to get rid of the wastes, "toxic traders" began shipping hazardous waste to developing countries.
- International outrage following these irresponsible activities led to the drafting and adoption of strategic plans and regulations at the Basel Convention.
- The Convention secretariat, in Geneva, Switzerland, facilitates and implementation of the Convention and related agreements.
- It also provides assistance and guidelines on legal and technical issues, gathers statistical data, and conducts training on the proper management of hazardous waste.
- The fundamental aims of the Basel Convention are the control and reduction of transports boundary movements of hazardous and other wastes including the prevention and minimization of their generation, the environmentally sound management of such wastes and the active promotion of the transfer and use of technologies.
- A Draft Strategic Plan has been proposed for the implementation of the Basel Convention. The Draft Strategic Plan takes into account existing regional plans, programmers or strategies, the decisions of the Conference of the Parties and its subsidiary bodies, ongoing project activities and process of international environmental governance and sustainable development.

- The Draft requires action at all levels of society: training, information, communication, methodological tools, capacity building with financial support, transfer of know-how, knowledge and sound, proven cleaner technologies and processes to assist in the concrete implementation of the Basel Declaration

**Table I: Effects of E-Waste constituent on health**

Source of e-wastes	Constituent	Health effects
Solder in printed circuit boards, glass panels	Lead (PB)	<ul style="list-style-type: none"> <li>• Damage to central and nervous systems, blood systems and kidney damage.</li> <li>• Affects brain development of children.</li> </ul>
Chip resistors and semiconductors	Cadmium (CD)	<ul style="list-style-type: none"> <li>• Toxic irreversible effects on human health.</li> <li>• Accumulates in kidney and liver.</li> <li>• Causes neural damage.</li> <li>• Teratogenicity.</li> </ul>
Relays and switches, printed circuit boards	Mercury (Hg)	<ul style="list-style-type: none"> <li>• Chronic damage to the brain.</li> <li>• Respiratory and skin disorders due to bioaccumulation in fishes.</li> </ul>
Corrosion protection of untreated and galvanized steel plates, decorator or harder for steel housings	Hexavalent chromium (Cr)	<ul style="list-style-type: none"> <li>• Asthmatic bronchitis.</li> <li>• DNA damage.</li> </ul>
Cabling and computer Housing	Plastics including PVC	<ul style="list-style-type: none"> <li>• Burning produces dioxin. It causes and Reproductive developmental problems;</li> <li>• Immune system damage;</li> <li>• Interfere with regulatory hormones</li> </ul>

A set of interrelated and mutually supportive strategies are proposed to support the concrete implementation is described below:

- 1) To involve experts in designing communication tools for creating awareness at the highest level to promote the aims of the Basel Declaration on environmentally sound management and the ratification and implementation of the Basel Convention, its amendments and protocol with the emphasis on the short-term activities.
- 2) To engage and stimulate a group of interested parties to assist the secretariat in exploring fund raising strategies including the preparation of projects and in making full use of expertise in non-governmental organizations and other institutions in joint projects.
- 3) To motivate selective partners among various stakeholders to bring added value to making progress in the short-term.
- 4) To disseminate and make information easily accessible through the internet and other electronic and printed materials on the transfer of know-how, in particular through Basel Convention Regional Centers (BCRCs).
- 5) To undertake periodic review of activities in relation to the agreed indicators;
- 6) To collaborate with existing institutions and programmers to promote better use of cleaner technology and its transfer, methodology, economic instruments or policy to facilitate or support capacity-building for the environmentally sound management of hazardous and other wastes.

The Basel Convention brought about a respite to the trans boundary movement of hazardous waste. India and other countries have ratified the convention. However United States (US) is not a party to the ban and is responsible for disposing hazardous waste, such as, e-waste to Asian countries even today. Developed countries such as US should enforce stricter legislations in their own country for the prevention of this horrifying act.

In the European Union where the annual quantity of electronic waste is likely to double in the next 12 years, the European Parliament recently passed legislation that will require manufacturers to take back their electronic products when consumers discard them. This is called Extended Producer Responsibility. It also mandates a timetable for phasing out most toxic substances in electronic products. It is estimated that 75% of electronic items are stored due to uncertainty of how to manage it. These electronic junks lie unattended in houses, offices, warehouses etc. and normally mixed with household wastes, which are finally disposed of at landfills.

This necessitates implementable management measures. In industries management of e-waste should begin at the point of generation. This can be done by waste minimization techniques and by sustainable product design. Waste minimization in industries involves adopting

- Inventory management
- Production-process modification
- Volume reduction
- Recovery and reuse.

### **Inventory management**

- Proper control over the materials used in the manufacturing process is an important way to reduce waste generation (Freeman, 1989).
- By reducing both the quantity of hazardous materials used in the process and the amount of excess raw materials in stock, the quantity of waste generated can be reduced.
- This can be done in two ways i.e. establishing material-purchase review and control procedures and inventory tracking system.
- Developing review procedures for all material purchased is the first step in establishing an inventory management program.
- Procedures should require that all materials be approved prior to purchase. In the approval process all production materials are evaluated to examine if they contain hazardous constituents and whether alternative non-hazardous materials are available.
- Another inventory management procedure for waste reduction is to ensure that only the needed quantity of a material is ordered.
- This will require the establishment of a strict inventory tracking system.
- Purchase procedures must be implemented which ensure that materials are ordered only on an as-needed basis and that only the amount needed for a specific period of time is ordered.

### **Production-process modification**

Changes can be made in the production process, which will reduce waste generation. This reduction can be accomplished by changing the materials used to make the product or by the more efficient use of input materials in the production process or both. Potential waste minimization techniques can be broken down into three categories:

- i) Improved operating and maintenance procedures
- ii) Material change and
- iii) Process-equipment modification.

- Improvements in the operation and maintenance of process equipment can result in significant waste reduction.

- This can be accomplished by reviewing current operational procedures or lack of procedures and examination of the production process for ways to improve its efficiency.
- Instituting standard operation procedures can optimize the use of raw materials in the production process and reduce the potential for materials to be lost through leaks and spills.
- A strict maintenance program, which stresses corrective maintenance, can reduce waste generation caused by equipment failure.
- An employee-training program is a key element of any waste reduction program.
- Training should include correct operating and handling procedures, proper equipment use, recommended maintenance and inspection schedules, correct process control specifications and proper management of waste materials.
- Hazardous materials used in either a product formulation or a production process may be replaced with a less hazardous or non-hazardous material.
- This is a very widely used technique and is applicable to most manufacturing processes.
- Implementation of this waste reduction technique may require only some minor process adjustments or it may require extensive new process equipment.
- For example, a circuit board manufacturer can replace solvent-based product with water-based flux and simultaneously replace solvent vapor degreaser with detergent parts washer.
- Installing more efficient process equipment or modifying existing equipment to take advantage of better production techniques can significantly reduce waste generation.
- New or updated equipment can use process materials more efficiently producing less waste.
- Additionally, such efficiency reduces the number of rejected or off-specification products, thereby reducing the amount of material which has to be reworked or disposed of.
- Modifying existing process equipment can be a very cost-effective method of reducing waste generation.
- In many cases the modification can just be relatively simple changes in the way the materials are handled within the process to ensure that they are not wasted.
- For example, in many electronic manufacturing operations, which involve coating a product, such as electroplating or painting, chemicals are used to strip off coating from rejected products so that they can be recoated.

### **Volume reduction**

Volume reduction includes those techniques that remove the hazardous portion of a waste from a non-hazardous portion. These techniques are usually to reduce the volume, and thus the cost of disposing of a waste material. The techniques that can be used to reduce waste-stream volume can be divided into two general categories: source segregation and waste concentration. Segregation of wastes is in many cases a simple and economical technique for waste reduction. Wastes containing different types of metals can be treated separately so that the metal value in the sludge can be recovered. Concentration of a waste stream may increase the likelihood that the material can be recycled or reused. Methods include gravity and vacuum filtration, ultra-filtration, reverse osmosis, freeze vaporization etc. For example, an electronic component manufacturer can use compaction equipments to reduce volume of waste cathode ray-tube.

### **Recovery and reuse**

This technique could eliminate waste disposal costs, reduce raw material costs and provide income from a salable waste. Waste can be recovered on-site, or at an off-site recovery facility, or through inter industry exchange. A number of physical and chemical techniques are available to reclaim a waste material such as reverse osmosis, electrolysis, condensation, electrolytic recovery, filtration, centrifugation etc. For example, a printed-circuit board manufacturer can use electrolytic recovery to reclaim metals from copper and tin-lead plating bath. However, recycling of hazardous products has little environmental benefit if it simply moves the hazards into secondary products that eventually have to be disposed of. Unless the goal is to redesign the product to use nonhazardous materials, such recycling is a false solution.

### **Sustainable product design**

Minimization of hazardous wastes should be at product design stage itself keeping in mind the following factors

- 1) **Rethink the product design:** Efforts should be made to design a product with fewer amounts of hazardous materials.  
For example, the efforts to reduce material use are reflected in some new computer designs that are flatter, lighter and more integrated. Other companies propose centralized networks similar to the telephone system.
- 2) **Use of renewable materials and energy:** Bio-based plastics are plastics made with plant-based chemicals or plant-produced polymers rather than from petrochemicals. Bio-based toners, glues and inks are used more frequently. Solar computers also exist but they are currently very expensive.

3) **Use of non-renewable materials that are safer:** Because many of the materials used are non-renewable, designers could ensure the product is built for re-use, repair and/or upgradeability. Some computer manufacturers such as Dell and Gateway lease out their products thereby ensuring they get them back to further upgrade and lease out again.

While the world is marveling at the technological revolution, countries like India are facing an imminent danger. E-waste of developed countries, such as the US, disposes their wastes to India and other Asian countries.

A recent investigation revealed that much of the electronics turned over for recycling in the United States ends up in Asia, where they are either disposed of or recycled with little or no regard for environmental or worker health and safety. Major reasons for exports are cheap labor and lack of environmental and occupational standards in Asia and in this way the toxic effluent of the developed nations 'would flood towards the world's poorest nations.

The magnitude of these problems is yet to be documented. However, groups like Toxic Links India are already working on collating data that could be a step towards controlling this hazardous trade. It is imperative that developing countries and India in particular wake up to the monopoly of the developed countries and set up appropriate management measures to prevent the hazards and mishaps due to mismanagement of e-wastes. Considering the severity of the problem, it is imperative that certain management options be adopted to handle the bulk e-wastes. Following are some of the management options suggested for the government, industries and the public.

### **Responsibilities of the Government**

- 1) Governments should set up regulatory agencies in each district, which are vested with the responsibility of co-coordinating and consolidating the regulatory functions of the various government authorities regarding hazardous substances.
- 2) Governments should be responsible for providing an adequate system of laws, controls and administrative procedures for hazardous waste management (Third World Network. 1991). Existing laws concerning e-waste disposal be reviewed and revamped. A comprehensive law that provides e-waste regulation and management and proper disposal of hazardous wastes is required. Such a law should empower the agency to control, supervise and regulate the relevant activities of government departments. Under this law, the agency concerned should
  - Collect basic information on the materials from manufacturers, processors and importers and to maintain an inventory of these materials. The information should include toxicity and potential harmful effects.

- Identify potentially harmful substances and require the industry to test them for adverse health and environmental effects.
  - Control risks from manufacture, processing, distribution, use and disposal of electronic wastes.
  - Encourage beneficial reuse of "e-waste" and encouraging business activities that use waste". Set up programs so as to promote recycling among citizens and businesses.
  - Educate e-waste generators on reuse/recycling options
- 3) Governments must encourage research into the development and standard of hazardous waste management, environmental monitoring and the regulation of hazardous waste-disposal.
  - 4) Governments should enforce strict regulations against dumping e-waste in the country by outsiders. Where the laws are flouted, stringent penalties must be imposed. In particular, custodial sentences should be preferred to paltry fines, which these outsiders / foreign nationals can pay.
  - 5) Governments should enforce strict regulations and heavy fines levied on industries, which do not practice waste prevention and recovery in the production facilities.
  - 6) Polluter pays principle and extended producer responsibility should be adopted.
  - 7) Governments should encourage and support NGOs and other organizations to involve actively in solving the nation's e-waste problems.
  - 8) Uncontrolled dumping is an unsatisfactory method for disposal of hazardous waste and should be phased out.
  - 9) Governments should explore opportunities to partner with manufacturers and retailers to provide recycling services.

### **Responsibility and Role of industries**

- 1) Generators of wastes should take responsibility to determine the output characteristics of wastes and if hazardous, should provide management options.
- 2) All personnel involved in handling e-waste in industries including those at the policy, management, control and operational levels, should be properly qualified and trained.

Companies can adopt their own policies while handling e-wastes. Some are given below:

- Use label materials to assist in recycling (particularly plastics).
- Standardize components for easy disassembly.
- Re-evaluate 'cheap products' use, make product cycle 'cheap' and so that it has no inherent value that would encourage a recycling infrastructure.

- Create computer components and peripherals of biodegradable materials.
  - Utilize technology sharing particularly for manufacturing and de manufacturing.
  - Encourage / promote / require green procurement for corporate buyers.
  - Look at green packaging options.
- 3) Companies can and should adopt waste minimization techniques, which will make a significant reduction in the quantity of e-waste generated and thereby lessening the impact on the environment. It is a "reverse production" system that designs infrastructure to recover and reuse every material contained within e-wastes metals such as lead, copper, aluminum and gold, and various plastics, glass and wire. Such a "closed loop" manufacturing and recovery system offers a win-win situation for everyone, less of the Earth will be mined for raw materials, and groundwater will be protected, researchers explain.
  - 4) Manufacturers, distributors, and retailers should undertake the responsibility of recycling/disposal of their own products.
  - 5) Manufacturers of computer monitors, television sets and other electronic devices containing hazardous materials must be responsible for educating consumers and the general public regarding the potential threat to public health and the environment posed by their products. At minimum, all computer monitors, television sets and other electronic devices containing hazardous materials must be clearly labeled to identify environmental hazards and proper materials management.

### **Responsibilities of the Citizen**

Waste prevention is perhaps more preferred to any other waste management option including recycling. Donating electronics for reuse extends the lives of valuable products and keeps them out of the waste management system for a longer time. But care should be taken while donating such items i.e. the items should be in working condition. Reuse, in addition to being an environmentally preferable alternative, also benefits society. By donating used electronics, schools, non-profit organizations, and lower-income families can afford to use equipment that they otherwise could not afford E-wastes should never be disposed with garbage and other household wastes.

This should be segregated at the site and sold or donated to various organizations. While buying electronic products opt for those that:

- Are made with fewer toxic constituents
- Use recycled content
- Are energy efficient.
- Are designed for easy upgrading or disassembly
- Utilize minimal packaging.

- Offer leasing or take back options.
- Have been certified by regulatory authorities.
- Customers should upgrade their computers or other electronic items to the latest versions rather than buying new equipment.

### **Sources, Collection, Treatment and Disposal of Hazardous Waste Hazardous Waste:**

Hazardous waste is used as a broad term to denote industrial by-products and waste materials discarded from homes, commercial establishments, and institutions that pose an unreasonable risk to human health and safety, property, and the environment. Most notable is the waste's potential cause of or contribution to increased mortality or an increase in serious irreversible or incapacitating, reversible illness.

**Agricultural land and agro-industry:** Hazardous wastes from agricultural land and agro-industry can expose people to pesticides, fertilizers and hazardous veterinary product wastes. Farms are a major source of these wastes, and agrochemicals can leach into the environment while in storage or can cause damage after their application

**Domestic:** Households stock various hazardous substances such as batteries and dry cells, furniture polishes, wood preservatives, stain removers, paint thinners, rat poisons, herbicides and pesticides, mosquito repellents, paints, disinfectants, and fuels (i.e. kerosene) and other automotive products. These can present a variety of dangers during storage, use and disposal.

**Mines and mineral processing sites:** Mining and mineral processing sites handle hazardous products that are present in the additives, the products and the wastes.

**Health care facilities:** Health care facilities are sources of pathological waste, human blood and contaminated needles. Specific sources of these wastes include dentists, morticians, veterinary clinics, home health care, blood banks, hospitals, clinics and medical laboratories.

**Commercial wastes:** Commercial waste sources include gasoline stations, dry cleaners and automobile repair shops (workshops). The types of hazardous wastes generated by these sources depend on service provided

**Industrial hazardous waste sources:** Hazardous wastes are created by many industrial activities. For example, the hazardous wastes from the petroleum fuel industry include the refinery products (fuels and tar), impurities like phenol and cyanides in the waste stream, and sludge flushed from the storage tanks.

**Solid waste disposal sites:** These are mainly disposal sites for municipal solid waste, but hazardous wastes that have not been properly separated from other wastes are also at these sites. In developing countries, solid waste disposal sites are a major source of pollutant-laden leachate to surrounding areas, as well as recyclable materials for scavengers, who can collect and resell waste materials that have been exposed to or that contain hazardous substances.

**Contaminated sites:** These are sites that are contaminated with hazardous wastes due to activities that use or produce hazardous substances or due to accidental spills

**Building materials:** Roofs and pipes made of materials incorporating asbestos, copper, or other materials may present a source of hazardous waste

**Transportation.** A transporter or carrier operates equipment to load hazardous waste at the point of generation and must ensure the safe and proper delivery of the waste to a permitted storage, treatment, and/or disposal site

The RCRA regulations for transportation of hazardous wastes require the transporter to

- Obtain an identification number
- Comply with the manifest for tracking the waste
- Retain a copy of the manifest for three years
- Deliver the entire quantity of waste to the selected designation
- Comply with applicable U.S. Department of Transportation regulations
- Clean up any hazardous wastes discharged during transportation For transporters, a discharge is defined as the accidental or intentional spilling, leaking, or in any way emptying of hazardous waste onto the land or into surface waters. Shipments may be made via road, rail, or water. The greatest potential for accidental discharge lies in the transfer of wastes between containment facilities.

**Treatment and Disposal.** The generators and disposers of hazardous waste complete the chain of responsibility under the manifest system. They must comply with RCRA regulations on facility standards and apply for a permit The focus of this chapter is the technology available to owners and operators of these facilities to comply with RCRA requirements. The source of hazardous waste at a treatment

and/or disposal facility is the individual waste(s) being handled.

The routes for environmental damage at these sites are

- Groundwater contamination via leaks or leachate
- Surface water contamination via runoff or overflows
- Air contamination via open burning, evaporation, and wind erosion
- Fire and explosion
- Poisoning via the food chain
- Human contact.

### **Effects of Hazardous Wastes**

The effects of hazardous wastes vary considerably with respect to human health and safety, property, and the environment. Sources of wastes are so numerous that site and waste characteristics are needed to define the timing and severity of local impacts.

### **Health**

Hazardous wastes may cause health effects by entering the body through inhalation, skin absorption, ingestion, or puncture wounds. Temporary effects include dizziness, headaches, and nausea; permanent effects include cancer, disability, and death. These effects may be evident immediately, or they may not be apparent for months or even years. The impact on health is also dependent on the amount and duration of hazardous waste exposure.

### **Safety**

Knowledge of proper safety attire and procedures is essential for personnel involved in cleanups and day-to-day hazardous waste handling activities. A site safety plan is needed to establish policies and procedures to protect workers and the public from potential hazards. includes minimum contents of a site safety plan; the plan should be updated as needed to reflect new conditions at either a cleanup site or handling facility.

### **Property**

Damage to private and public property and the physical environment is most likely to result from fires and explosions at hazardous waste sites. In addition to creating hazards through intense heat and smoke, open flames, and flying debris, fires and explosions may emit hazardous substances to the atmosphere. Most often, fires and explosions result from investigative or remedial activities, such as accidentally mixing incompatible contents of drums, or from introduction of an ignition source, such as sparks from equipment.

## **Environment**

The potential adverse effects on the air, water, and land environment are as varied as the numbers of hazardous wastes. In addition to environmental consequences of improper handling of hazardous waste, there is almost always an associated risk to human health.

Guidelines for hazardous waste handling facility performance with respect to human health and the air, water, and land environment are presented in. These guidelines were developed from specific standards published by the EPA for new landfills, surface impoundments, land treatment facilities, and underground injection wells. The risks of environmental damage from hazardous wastes obviously can be lessened by the reduction or elimination of waste generation. Waste reduction is a critical and promising technological challenge to develop practices of product substitution, process modification, source segregation, and recycle, recovery, and reuse. In some cases, government action is used to stop the production of particularly hazardous substances.

## **Waste Minimization**

Waste minimization (pollution prevention) practices are not only intended to protect and improve human health and the environment but also are means to reduce costs, build community relations, demonstrate environmental leadership, and reduce the impacts of state and federal requirements. Waste minimization consists of source reduction and recycling, which consist of a number of practices and approaches, as illustrated in. Source reduction usually is preferable from an environmental protection perspective. The EPA's Waste Minimization National Plan outlines a long-term national effort to reduce the quantity and toxicity of hazardous wastes. The plan proposes mechanisms and implementation methods for affecting waste minimization. Key components of the plan include establishing goals, setting priorities for waste source reduction and recycling efforts, identifying and evaluating source reduction and recycling opportunities, arraying mechanisms for affecting source reduction and recycling, implementing mechanisms, and measuring progress. The goals of the Waste Minimization National Plan are to:

- Reduce by 50% the most persistent, bio accumulative, and toxic (PBT) chemicals in the nation's hazardous waste by the year 2005, as compared with the baseline year of 1991.
- Emphasize source reduction (reducing waste at its source, before it is even generated) and environmentally sound recycling, over waste treatment and disposal. Prevent transfers of chemical releases from one medium (air, water, or land) to another.
- In particular, the reduction in the presence of PBT chemicals in waste will reduce long-term threats to human health and the environment because:

- Persistent (P) chemicals generally do not break down in the environment.
- Bio accumulative (B) chemicals tend to concentrate in animal and plant tissue.
- Highly Toxic (T) chemicals can cause cancer or other health effects in humans, and greatly endanger the environment. The waste minimization assessment procedure, illustrated in is a means for waste generators to support the success of the national plan. First, generators establish waste minimization goals at their facilities and then develop and carry out a program to achieve or exceed the goals. identifies some of the facility information that may be needed or acquired. Often, the assessment phase begins with the identification of PBT chemicals on site and determination of the processes producing PBT waste. Finally, source reduction and recycling alternatives are evaluated, selected, and implemented to eliminate or reduce PBT waste.

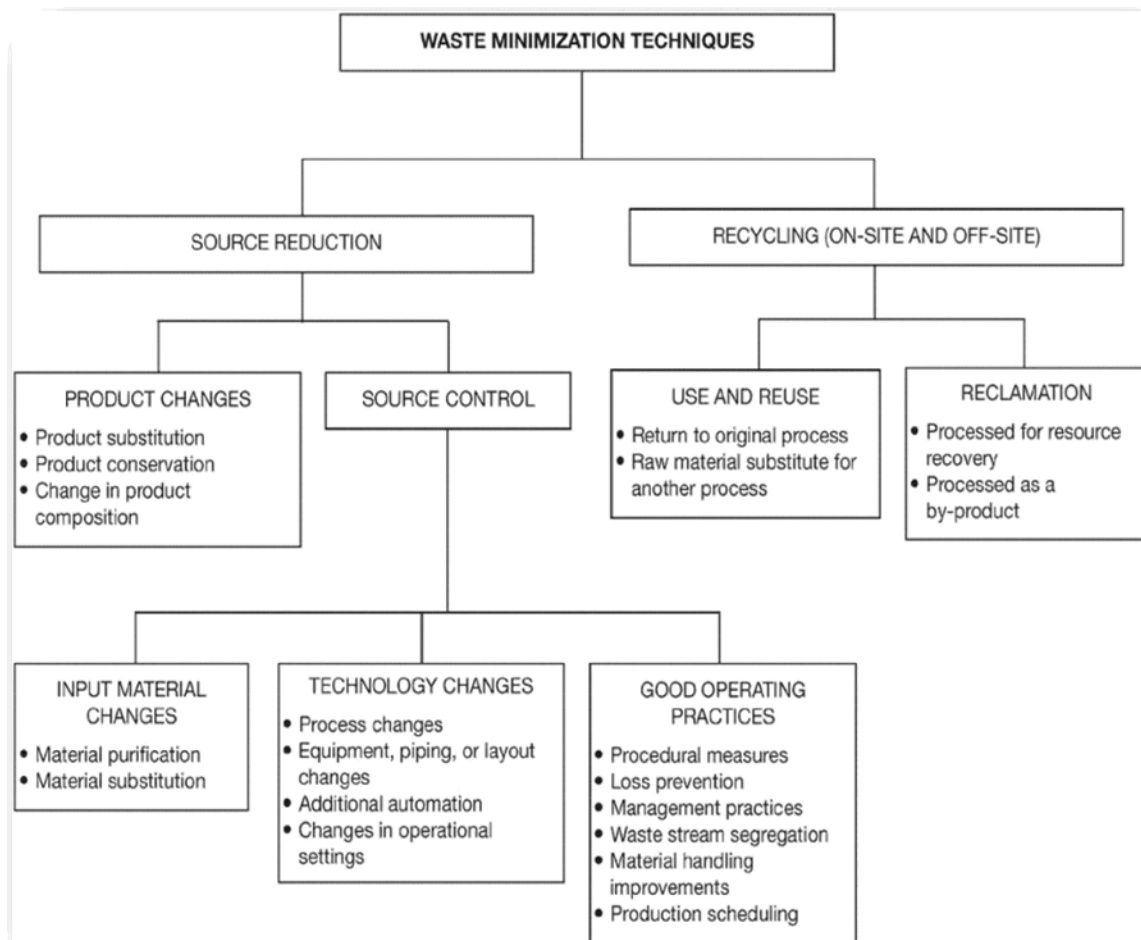

## **Biological Treatment**

- Aerobic and Anaerobic Systems Industrial organic wastewater is generally a high-volume discharge of BOD/COD that can vary in the type of organic material present, the constancy of the feed specifications, the content of inorganic nutrients, the presence of substances toxic to the biomass, and the diurnal flow pattern.
- Biological treatment processes can be broadly classified into two categories depending on the level of oxygen present in or supplied to the waste in the digestion vessel.
- A high oxygen concentration (minimum requirement of 0.5 ppm free dissolved oxygen) promotes the growth of aerobic bacteria, biological reactions proceeding via oxidation.
- Thus, sulphur, nitrogen and phosphorus containing compounds in the wastewater are converted to low-energy end products such as sulphates, nitrates, and phosphates: the energy necessary for respiration and for the synthesis of new cells is also generated by oxidation of carbonaceous cellular material. In the absence of oxygen, anaerobic bacteria thrive.
- The end products of degradation are decomposed liquor that normally requires further treatment prior to discharge, and a gas comprising mainly of methane and carbon dioxide.
- Effective anaerobic treatment relies on an optimum balance between non-methanogenic and methaneproducing organisms in order to ensure that the energy in the waste is not retained in the liquor in the form of partially decomposed organics, but is evolved as a gas.

## **Physical and Chemical Treatment**

- Hazardous wastes that need treatment or disposal may be freshly generated from an industrial operation, they may be old stored chemicals, or they may have been sitting in a dumpsite for many years.
- At a dumpsite, component chemicals difficult to identify, they are likely to have reacted with one another, and they may have already affected the surrounding soil and water.
- Land disposal and incineration are two main dumpsite remediation methods.
- Types of waste treatment include physical, biological, and chemical neutralization or stabilization.
- Some treated hazardous wastes can even be reclaimed or recycled.
- Industries in the United States dispose of about 60% of their hazardous waste using a land disposal method called deep well injection.

- Liquid wastes are injected into wells located in impervious rock formations that supposedly keep the waste isolated from groundwater and surface water.
- Unfortunately, hydro geologists now predict that groundwater flow actually does occur in most previously-designated impervious rock formations, and injected waste often migrates into groundwater reservoirs called aquifers.
- Other underground burial locations for hazardous wastes include deep mines, natural caverns, and man-made deep pits. Landfilling is the other primary land disposal method for hazardous waste disposal in the United States.
- Hazardous waste landfills are similar to regular solid waste landfills, but they must meet much higher standards for safety and environmental protection.
- The EPA requires that most hazardous wastes be treated before being discarded in properly-designed, approved landfills and burial sites. Incineration, or burning, is a controversial, but still common, method of handling hazardous wastes.
- The EPA estimates that five million tons of hazardous wastes are burned each year in the United States.
- Various incineration technologies exist for a variety of types of waste. For example, volatile chemicals like paint thinners, oils, and solvents are destroyed by combustion at cement plants whose furnaces, called kilns, reach temperatures of 2,700°F (1,500°C).
- Needless to say, residents living near cement plants and other hazardous waste incinerators often have concerns about air pollution.
- In 1993, the EPA tightened its regulations on emissions from most hazardous waste incinerators, including cement kilns, after discovering that the emissions contained like dioxins, furans and other substances that cause cancer and other health problems in humans.
- Another recent EPA study noted that medical waste incinerators that many hospitals use to burn hazardous wastes also emit dioxins.
- Some hazardous wastes, including certain tars, drilling muds, and mining sludge's, are relatively well-suited for incineration.
- Some other wastes, however, should not be burned, such as those that contain heavy metals.
- Burning does not destroy the metals, and they end up in the incinerator ash.
- Ash from hazardous waste incinerators that contains high concentrations of metals is a dangerous material in its own right, and requires careful disposal.
- Stabilization, also called solidification, is a physical treatment method sometimes used on incinerator ash and other hazardous wastes before landfilling or underground burial. In this method, additives are combined with

the waste material to make it more solid, or to prevent chemical reactions.

- Other physical treatment methods include soil washing at hazardous waste dumpsites, filtering hazardous waste solids out of liquids, and distillation.
- Various biological treatments utilize microbes to break down wastes through a series of organic chemical reactions.
- Through these methods, substances that could cause damage to humans or the environment can be rendered harmless.
- New substances created by microbial reactions may be suitable for reuse or recycling. Research in genetic engineering, though controversial, could lead to breakthroughs in biological treatment.
- In chemical treatment, materials are added to or removed from the hazardous waste to produce new, less hazardous chemicals.

## **Construction Waste**

### Sources of Construction Waste Material

- Woody and plant materials
- Concrete
- Gravel, aggregate, stone and rock
- Masonry and rubble
- Metals (ferrous and non-ferrous)
- Wood
- Plastic
- Glass
- Doors and windows
- Asphaltic roofing
- Gypsum board
- Carpet and pad
- Cardboard and paper
- Plumbing fixtures
- Lighting fixtures

## **Collection of Construction Waste**

The construction and demolition waste includes waste forming during construction, reconstruction, repairs or demolition of buildings, also a construction product waster. Construction waste is collected from enterprises, organizations and individuals by containers, according to a certain schedule. The construction and demolition waste is brought to inert waste dumps; there they are further recycled or utilized. To reduce volumes of waste getting into dumps, we offer our customers to

sort construction waste in places where it is forming – to separate demolition waste from finish, accumulate unpolluted concrete waste separately. A part of construction waste may be recycled; a part of it may be used for road reconstruction or in other fields. Construction and big-sized waste forming during construction, repairs or demolition of buildings may be collected in three ways:

On special routes: according to a schedule settled in advance waste is collected from yards of apartment buildings and sites of domestic waste containers located near buildings; In construction waste containers: special metal containers are placed in residential or commercial areas or building lots. Their capacity may amount to from 5 up to 20 m. Full containers are replaced by empty ones; In big-bags: this pre-payable service is especially important to individuals or enterprises, holding low amounts of construction or big-sized waste – those who are repairing their homes or willing to get rid of unnecessary things. Also, to those who are not willing to hire a construction container or have no place for it. 5–10 m, 28–38 m, 14–18 m&3 –2 m

- A metal open container used for big-sized and heavy waste.
- Convenient to throw waste.
- A very big capacity metal container, used for light waste.
- A metal open container, used for large size and heavy waste.
- Container's height is convenient for throwing the waste in the construction site.
- Can be loaded with up to 2 cubic meter of waste.
- Occupies little space.
- Durable and light.

### **Waste Collection Methods Types of Containers**

Every 10 years at such frequency most Lithuanians are repairing their homes. Vehicles Special purpose vehicles with different lifting mechanisms are used for collection of construction waste. All the used vehicles are technically good, engines correspond with euro standard requirements - fuel-effective, environmentally safe.

- For those residents who are repairing 60 sq. m home, we recommend to choose two 1 sq. m or one 2 sq. m big-bag. It is possible to pay for a bag via bank transfer or in cash.
- For those customers who are constructing or demolishing 150 sq. m building, we recommend to choose a 10 sq. m metal container. A container is emptied twice a week or the other day following the notice about the loaded container. It is possible to pay for the service via bank transfer or in cash after the service is rendered.
- For those who are building big objects, such as apartment buildings, business or commercial and recreational centers, we will present an individual proposal.

We offer the most comfortable and economical method of waste management, taking into consideration a size of With our expert sorting and diversion initiatives, your construction recycling plan becomes easy and cost- effective. You'll always remain in compliance with your project plan and city ordinances, and these diversion efforts can help you achieve valuable points towards Leed certification. Whether you're getting rid of old concrete, construction and demolition debris, or landscaping materials, Waste Management works with you to develop C&D recycling programs that work for you, and the environment. You can recycle most common construction materials with Waste Management, including.

- Porcelain
- Rigid plastics
- Tile
- Timber
- Metals
- Masonry
- Plastic
- Rock
- Carpet

### **How Construction Debris Recycling Works**

The goal of every recycling program is to retain as much value as Possible. We'll help you do that by turning your construction debris Into new resources, such as:

- Inserts that become road base
- Cardboard, paper, plastics, and metals can be converted into new goods
- Clean wood becomes mulch or biomass fuel
- Dirt, rock, and sand become Alternative Daily Cover (ADC) in landfills
- Crushed concrete becomes gravel or dry aggregate for new concrete.

### **Treatment of Construction Waste**

- Application of Recycled C&D Waste Germany's annual raw construction material demand is far higher than the annual amount of recycled building material, implying that all recycled C&D material can potentially be absorbed by the construction industry alone.
- This is not however the case and it appears that a major reason is that engineers and architects have not been able to specify recycled material without assurances that it will perform equivalent to new materials.
- Much progress, however, has been made in this regard, particularly in terms of setting and verifying engineering standards for recycled building material,

particularly for use in higher value applications.

- While applications such as road construction are valid and cost effective for many C&D materials they imply a down cycling aspect, for example, from structural components such as brick and concrete, to road base crush.
- The German Institute for Quality Assurance and Marking operates a certification program for C&D material allowing recyclers to market their materials with the confidence that they are suitable for a particular application.
- Likewise, a builder or material specifier (architect or engineer) may compare new materials with certified recycled materials, and take better advantage of the cost savings and ecological benefits inherent in recycled material.
- Germany has elaborated several regulations and indications determining standards for recycling materials in order to utilize them and make them an alternative to new materials. Most of them are used in road construction.
- Some guidelines for the use of recycled mineral materials.

# **MODULE-5**

## **Incineration**

- Incineration can be defined as a controlled combustion process for burning of solid, liquid and gaseous combustible wastes to gases and residue containing non-combustible materials.
- Burning of refuse at high temperatures in furnaces is called Incinerator. Incineration is one of the chemical processes used to reduce the volume of solid wastes.
- The process can also be called as chemical volume reduction. Earlier Chemical reduction was used to recover grease from Food wastes, and in the process volume was reduced.
- At present this is one of the common methods used to reduce the volume of wastes chemically.
- Chemical processes such as pyrolysis, hydrolysis and chemical conversion are also effective in reducing the volume of wastes. Incineration is now used both for volume reduction and for power production. .
- Normally, only the combustible matter, such as garbage, rubbish and dead animals are burnt, and the incombustible matter like broken glass, chinaware, metals, etc. are either left un burnt or are separated out for recycled and reuse before burning the solid wastes.
- The end, products, ashes and linkers from the incinerators along with the non-recycled incombustible materials may, however, measure as much as 10- 25% of the original waste, which in any case, shall have to be disposed of either by sanitary Land filling, or in some other productive manner.
- For example, the clinkers can be used as aggregates for making Low grade concrete or as road metal and the ashes can be used for making bricks.
- The heat produced during burning of the refuse is used in the form of steam power for running turbines to generate electricity.

## **3Ts of Incineration Process**

### **Time:**

Solid wastes are exposed for sufficient time to turbulent atmosphere for complete combustion. When a fuel is being burned, it is important that sufficient time is available so that the fuel burns completely. 100% combustion means that the fuel is fully oxidized and full oxidation of the carbon, hydrogen and other combustible

elements has taken place. If fuel remains in the combustion zone for a time lesser than necessary, it will be partially burned which increases the un-burnt losses. On the other hand, if it remains for a time higher than the required, the power output of the boiler will drop as new fuel will not be able to come in and get burned. Ideally, the fuel should stay for a time sufficient for the complete combustion and then replaced by the fresh fuel.

### **Temperature:**

The temperature range for incineration process varies from 5500C-10000 c. Temp Range is controlled to be above 7500C to ensure adequate combustion and below 10000 c to prevent ash melting and clogging the grate. The temp is controlled by the addition of dilution air to the furnace as required. During the combustion, if the temperature is not sufficiently high, fuel will take some time to ignite thus increasing the time of the combustion. This will affect the heat output. Hence, it is very important to maintain correct temperature which ensures that fuel is quickly burnt releasing the complete energy.

### **Turbulence**

Turbulence ensures mixing of each volume of gas with sufficient air for complete burning of volatile combustible matter and suspended particulates. Some turbulence and mixing of wastes within the bed on the grate is also required. Oxygen makes an essential part of the process of combustion. While burning the fuel, it is essential that it is broken down in small particles. This increases the surface area of the fuel and ensures that sufficient air i.e. oxygen is made available. Turbulence ensures a thorough mixing of the air and the fuel. If turbulence is not maintained, certain part of the fuel will have excess oxygen available for the combustion while the remaining having too little. This will result in incomplete combustion of carbon forming carbon monoxide instead of carbon dioxide. If proper turbulence is not maintained, some part of the fuel will go out of the chimney without even getting oxidized. This will increase the un-burnt losses.

### **Three Ts of Combustion: Time, Turbulence And Temperature**

The process of combustion is probably the most important process taking place inside the boiler. Through combustion, the energy contained within the fossil fuels is released and then used to generate steam or hot water as the process demands. The purpose of combustion is to release the heat from fuel and make it available for the further use. It is essential that the combustion is Complete so that the complete amount of energy present in the fuel is utilized quick so that the required heat output is produced In coal fired boilers or any boiler for that matter, efficiency of combustion plays an important role in determining the overall boiler efficiency. The combustion of fuel should be quick and complete. The process of combustion

is complex in nature and multiple parameters affect the combustion efficiency. Out of these several parameters, time, turbulence and temperature are referred to as 3 Ts of combustion.

### **Factor Affecting Incineration (3ts)**

Incineration to be an effective method for destroying wastes, combustion must be complete. Three critical factors ensure the completeness of combustion in an incinerator:

1. The temperature in the combustion chamber.
2. The length of time wastes is maintained at high temperatures.
3. The turbulence or degree of mixing, of the wastes and the air.
4. Operating conditions are specified in each incinerator permit to ensure that these factors are present to promote complete combustion.

Municipal solid waste (MSW) is more commonly known as trash or garbage consists of:

- General Household refuse including food scraps and newspapers
- Product packaging, bottles and containers
- Grass clippings
- Furniture
- Household industrial products such as paints and solvents
- Clothing

### **Incineration of Municipal Wastes**

One of the most attractive features of the incineration process is that it can be used to reduce the original volume of combustible solid wastes by 80 to 90%. In some of the newer incinerators designed to operate at temperatures high enough to produce a molten material before cooling, it may be possible to reduce the volume to about 5 percent or less although the technology of incineration has advanced in the past two decades, air pollution control remains a major problem in implementation. In addition to the use of large municipal incineration is also used at individual residences, apartments stress, industries, hospitals and other institutions.

## Municipal Incinerators

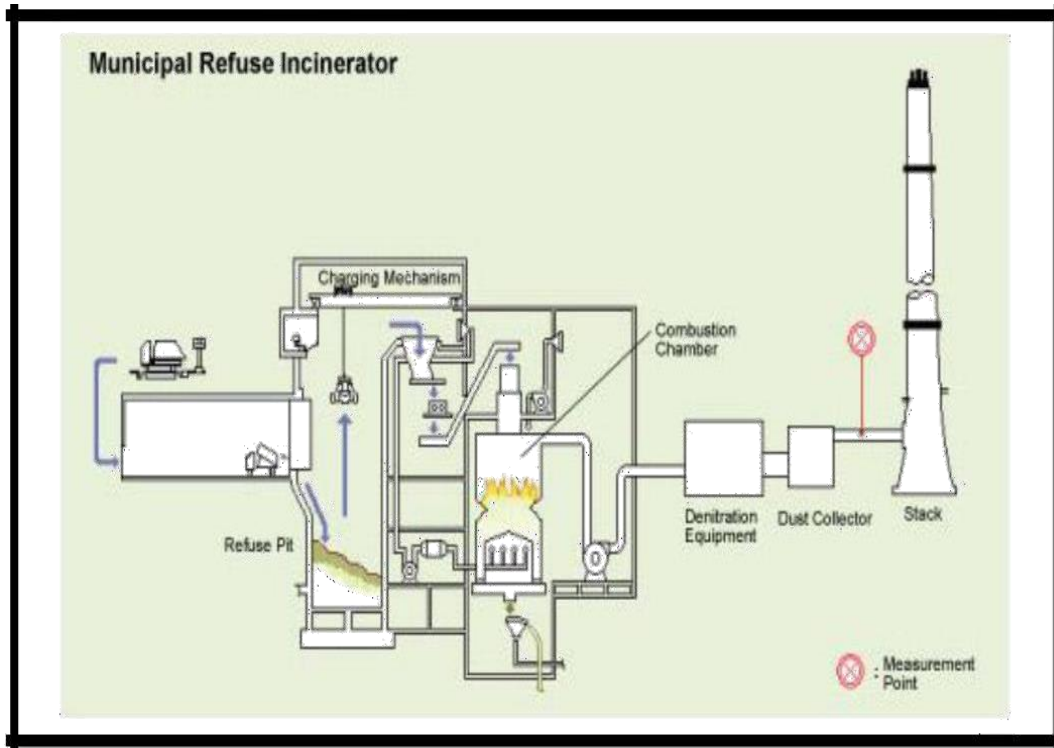

- The operation begins with the unloading of solid wastes from collection trucks into a storage bin.
- The length of the unloading platform and storage bin is a function of the number of trucks that must unload simultaneously.
- The overhead crane is used to batch load wastes into the charging hopper.
- The crane operator can select the mix of waste to achieve a fairly even moisture content in the charge.
- Large or incombustible items are also removed from the wastes. Solid wastes from the charging hopper fall into the stokes where they are mass-fired. Several different types of mechanical stokers are commonly used.
- Air may be introduced from the bottom of the grates (Under fire air) by means of a forced draft fan or above the grates (over-fire air) to control burning rates and furnace temperature.
- The hottest part of the fire is above the burning grate.
- Various gases are driven off in the combustion process taking place in the furnace, where the temperature is about 14000F.

- These gases and small organic particles poses into a secondary chamber, commonly called a “Combustion chamber” and burn at temperatures in excess of 16000 F.

### **Emission Control Facilities and Equipment for Municipal Incinerators**

ITEM	DESCRIPTION
Settling chamber	A Large chamber usually located immediately after combustion chamber for removal of large fly ash particles and as pre-treatment operation for subsequent removal processes.
Baffle collectors	<p>Baffles constructed of brick or metal that can be operated in wet or dry mode.</p> <p>Usually Located after combustion chamber Particles 50um or</p> <p>Larger can be removed by impingement, Efficiency depends on design and placement</p> <p>Fly ash is impacted on water droplets and subsequently removed. Method of removing wetted Fly ash depends onequipment to be used and design of incinerator</p>
Scrubber	Dry Separation of Fly ash particles by means of centrifugal action in which particles are thrown or impinged against walls of collector.
Fabric Filter	Electrode charged particles are removed on collecting surfacesplaced in an electrical field of high intensity. Once on the collecting surface, particles loose charge and adhere lightly can be moved by light tapping

## Electrostatic Precipitator

- The Electrostatic precipitator (ESP) was the First particle control device used on MSW (<10um) and very fine (<2um) particles.
- They operate on the principle of Electrostatic Attraction.
- A high negative voltage 20,000 to 1,00,000 volts, applied to the discharge electrodes, produce a strong electric field between the discharge and collector electrodes.
- Particles in the gas stream acquire a negative charge as they pass through the electrical field.
- Because of their charge, the particles are then attracted to the grounded collection electrode.
- After collection on the plates, particles are removed by mechanical vibration of the plates.
- Fabric Filter the Fabric Filter has become the Technology of choice on most recently constructed MSW combustion systems in the United States.
- The fabric Filter or Bag house as it is sometimes referred to is an inordinately simple device.
- A number of Filter bags are connected in parallel in housing. Particles gradually build up on the surface of the fabric.
- The dust bed allows the fabric to filter particles as small as 0.1um, much smaller than 50-70 open space b/n the fibers of the fabric. As particles build up on the surface of the Fabric.

**ELECTROSTATIC PRECIPITATOR DIAGRAM**

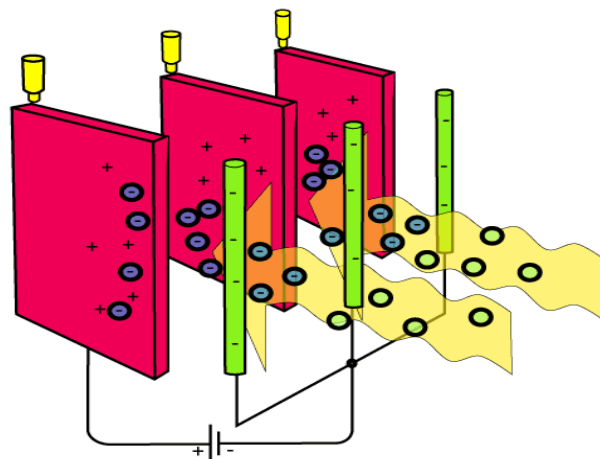

## Different Types of Mechanical Stokers Travelling Grate

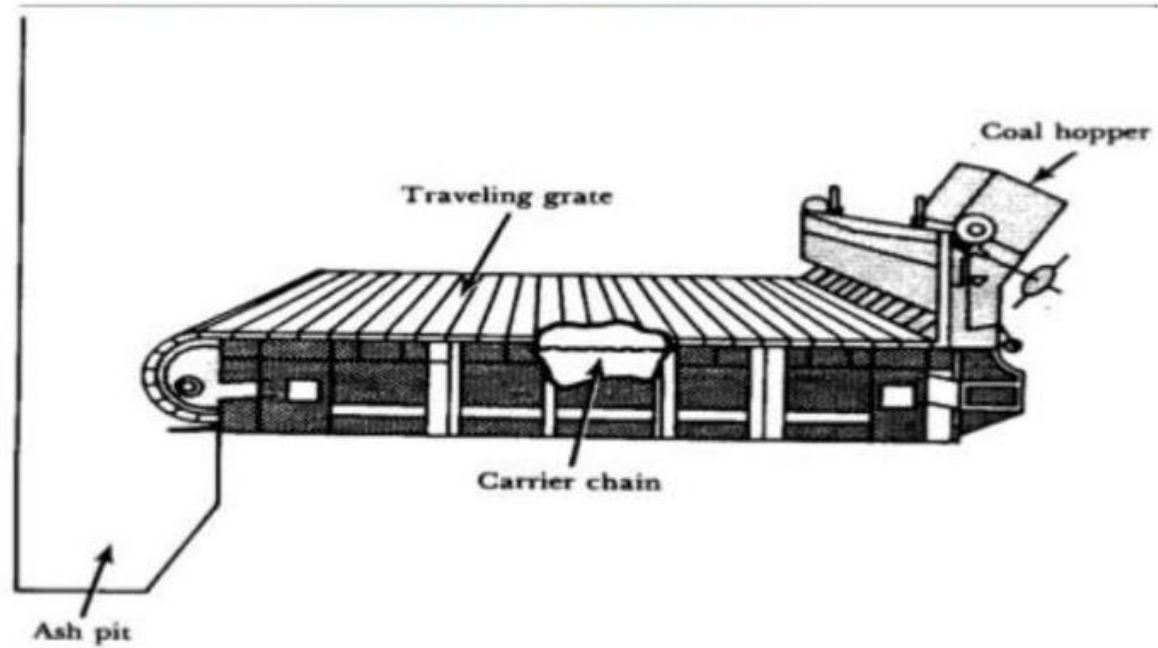

- Consists of a continuously moving feeder grate and one or more burner grates.
- Feeder grate is located directly under a charging hopper from which wastes fall onto grate wastes are partially dried while on feeder grate.
- Wastes are moved through Furnace from the hopper while grate is actually stationary, except for alternating reciprocating movements of component stake bars.
- Burning rate is adjusted by controlling the speed of stoke bars. The mechanical stoker simply pointed the way to the use of powdered coal, and, as the use of this class of coal is developed, mechanical stokers will necessarily pass away.
- There are many different types of mechanical stokers, of which the following might be mentioned:—The Crawford Underfeed Stoker, the Street Locomotive, the Hanna Locomotive, the Standard Locomotive, the Barnum Underfeed, the Strouse Overfeed, the Hayden, the Dickinson Overfeed, the Brewster Underfeed, and the Rail Locomotive Stoker

## Reciprocating Grate

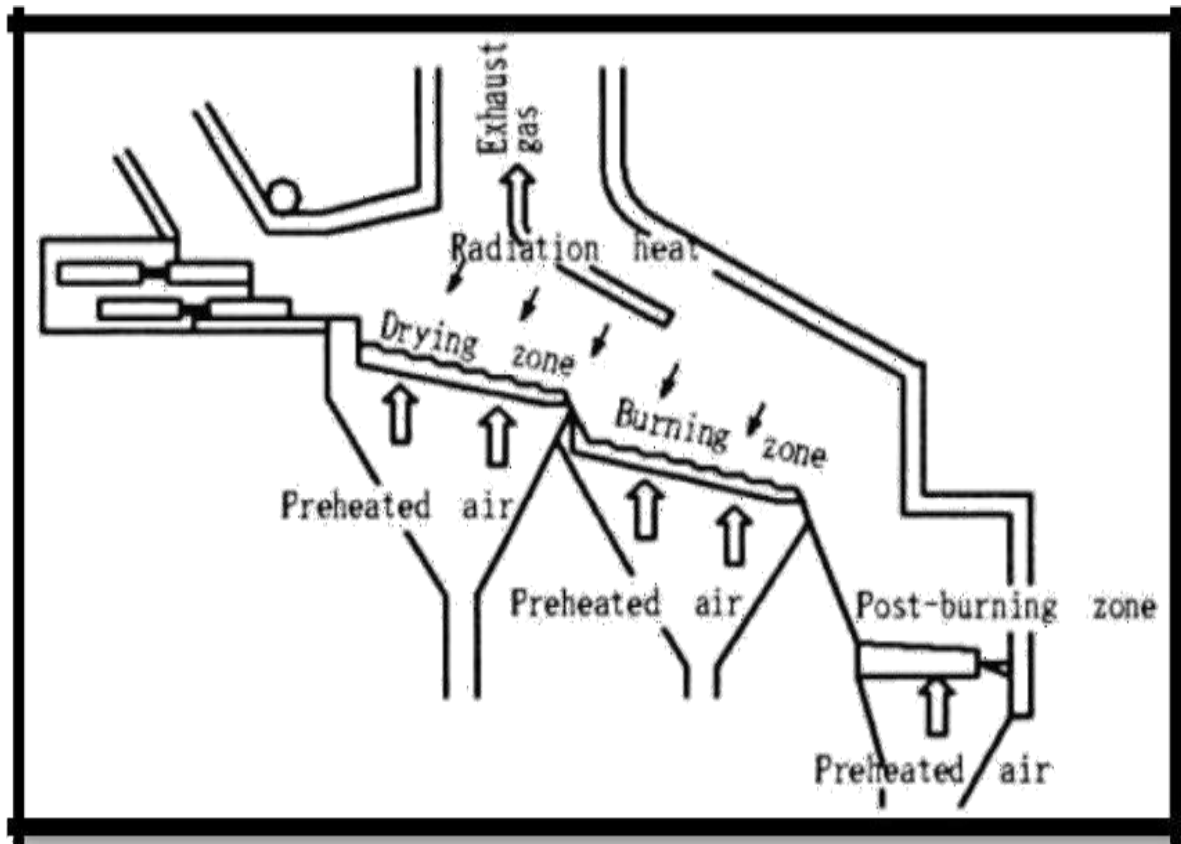

Operation is similar to reciprocating grate but wastes are moved through the furnace by the rocking action of the grates. Relatively new design wastes are burned as they are moved by a series of rotating barrels.

## Pyrolysis

- Out Of the many alternative', chemical conversion processes that have been investigated excluding incineration, pyrolysis has received the most attention.
- Because most organic substances are thermally unstable, they can upon heating in an oxygen-free atmosphere, be split through a combination of thermal cracking and condensation reactions into gaseous, liquid and solid fractions, pyrolysis is the term used to describe the process. In contrast to the combustion process which is highly exothermic, the pyrolysis process is highly endothermic.

- For this reason, the term destructive distillation is often used as an alternative term for pyrolysis.
- At present time a number of different types of reactors are being evaluated for this application.
- Depending on the type of rectory used, the physical form of the solid wastes to be paralyzed can vary from UN shredded raw wastes to the finely ground portion of the wastes remaining after two stages of shredding and air classification

**Conversion Products:**

The characteristics of the three major component fractions resulting from the pyrolysis are. Pressure drop across the fabric filter gradually increases. The particles are removed from the filter bags by several Techniques, including mechanical shaking reverse air Flow, and pulse jet.

**Design and Performance Considerations**

The Principal elements that must be considered in the mechanical design of an incinerator are summarized in table below.

COMPONENT	PURPOSE/DESCRIPTION
Scales	Required to maintain accurate records of the amount of wastes processed.
Storage pits	Design of pits depends on furnace capacity, storage requirements (approximately 1-day capacity) collection schedules and truck dischargemethods.

Cranes	Constructed of metal or concrete used to introduce wastes to furnace grates.
Charging hoppers	Used to move wastes through furnace Travelling, reciprocating, rocker arm and barrel grates have been used successfully. Burning rate of 60-65 lb/ft <sup>2</sup> /h has been adopted,
Furnace grates	“generally allowable” standard for massfiring.
Combustion factor	Water walled and refractory chambers are used  Types of systems vary Typically, two baller
Auxilar heat	Need depends on moisture content of wastes as

1. A gas stream containing primarily hydrogen methane, carbon monoxide, carbon dioxide, and various other gases depending on the organic characteristics of the material being pyrolysis.
2. A fraction that consists of a tar and/or oil stream that is Liquid at room temperatures and has been found to contain chemicals such as acetic acid acetone and methanol.
3. A char consisting of almost pure carbon plus any inert material that may have entered the process.

## Materials and Energy Recovery Operations

- Once solid waste has been converted to thermal energy in the form of steam by combustion or to chemical energy in the form of gases or Liquids by pyrolysis or gasification, it can be converted to mechanical or Electrical energy processes or building heating.
- Steams can also energy with a steam turbine gases and liquid produced from solid waste by both thermal boilers to produce stream.
- Cases and liquids engines and gas turbines. The purpose of this section is three fold.
  1. To present basic flow diagrams available for accomplishing these conversions.
  2. To present data on the efficiency of the process flow diagrams.
  3. To illustrate the use of efficiency data in computing energy output.

### Energy Recovery Flow Diagrams:

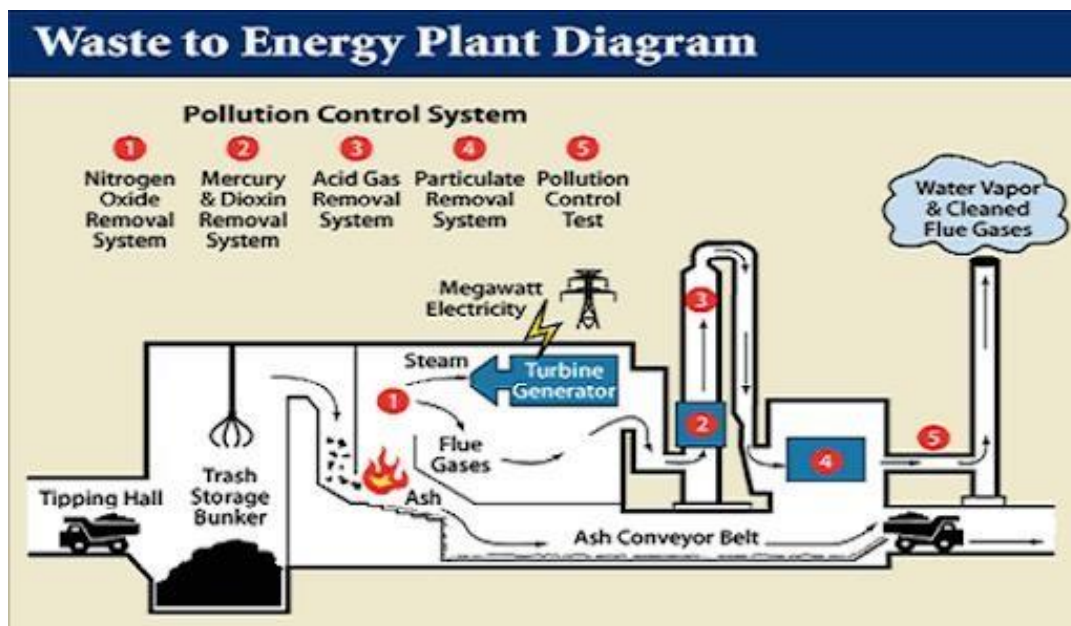

## **Energy recovery**

- Includes any technique or method of minimizing the input of energy to an overall system by the exchange of energy from one sub-system of the overall system with another.
- The energy can be in any form in either subsystem, but most energy recovery systems exchange thermal energy in either sensible or latent form.
- In some circumstances the use of an enabling technology, either diurnal thermal energy storage or seasonal thermal energy storage (STES, which allows heat or cold storage between opposing seasons), is necessary to make energy recovery practicable.
- One example is waste heat from air conditioning machinery stored in a buffer tank to aid in night time heating.
- Another is an STES application at a foundry in Sweden. Waste heat is recovered and stored in a large mass of native bedrock which is penetrated by a cluster of 140 heat exchanger equipped boreholes (155mm diameter) that are 150m deep.
- This store is used for heating an adjacent factory as needed, even months later. An example of using STES to recover and utilize natural heat that otherwise would be wasted is the Drake Landing Solar Community in Alberta, Canada.
- The community uses a cluster of boreholes in bedrock for interpersonal heat storage, and this enables obtaining 97 percent of the year-round space heating from solar thermal collectors on the garage roofs.
- Another STES application is recovering the cold of winter by circulating water through a dry cooling tower, and using that to chill a deep aquifer or borehole cluster.
- The chill is later recovered from the storage for summer air conditioning.
- With a coefficient of performance (COP) of 20 to 40, this method of cooling can be ten times more efficient than conventional air conditioning.
- The principal components used for energy recovery are boilers and reciprocating engines as prime movers for mechanical energy and electric generators for the conversion of mechanical energy into electricity.

## Steam Turbine Systems

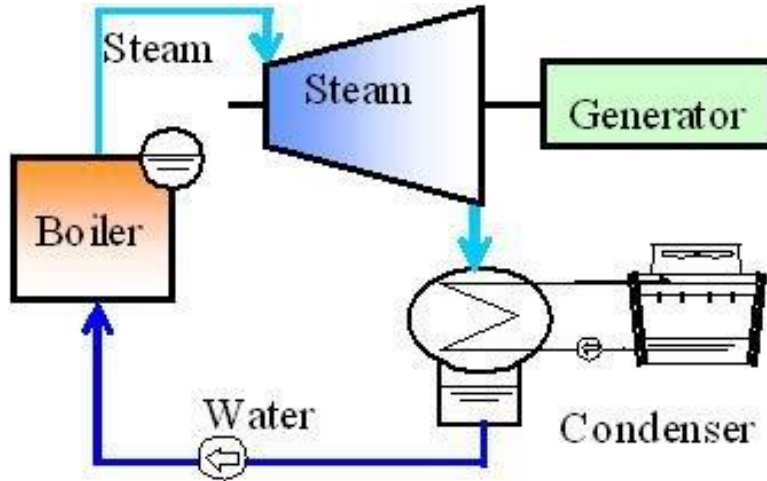

The most common energy recovery system for the production of electricity is the steam turbines, system. Steam (gaseous or liquid conversion products can also be used). The steam is used to drive a steam turbine and then condensed back into boiler feed water. The steam turbine drives an Electrical generator, which supplies on site power and excess power for export. The System is essentially a scaled down version of a coal or gas fired electrical utility plant.

## Gas Turbine Generator Systems

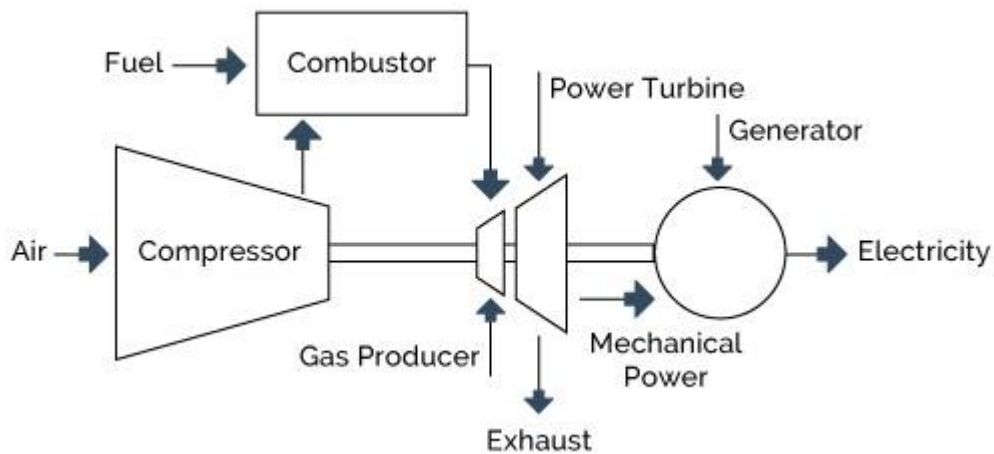

- Gas turbines require gaseous or liquid Fuels.
- These fuels can be supplied by biological processes such as land fill gas or the anaerobic digestion of MSW, or by pyrolysis or gasification.

- A gas turbine is similar to a jet engine. In that it consists of a compressor section to increase the density of gas/air mixture, a compressor and a tubing section to convert the hot combustion gases to mechanical energy.
- An electrical generator is connected directly to the output shaft of the gas turbine. Gas turbines are efficient and compact and widely used in Landfill gas systems.

### **Internal Combustion Engine Systems**

- Internal combustion engines using pistons and crank shaft are an alternative to gas turbines for gaseous or liquid fuels from the thermal or biological processing of solid wastes.
- The engines are modified versions of industrial engines designed for natural gas or propane.
- Because natural gas has an energy content of about 1000 Btu/ft<sup>3</sup> compared to 400 to 500 Btu/ft<sup>3</sup> for Landfill gas and 150 to 300 Btu/ft<sup>3</sup> for Low Btu gas, the engines are modified carburetors and intake manifolds to handle the lower quality gas.
- Internal Combustion engines are the most common prime movers used in Landfill gas recovery systems.

### **Cogeneration Systems**

- Cogeneration is defined as the generation of both thermal and electrical power.
- Cogeneration systems are widely used in industry to generate electricity and process or building heat at the same time.
- Applications in energy recovery from solid waste are limited by the requirement that a use for the heat recovered must be located at the site with the power generation system.
- In steam turbine systems, steam for heating is generated by extracting some of the steam from the fabric filters on recent installations has exceeded the most strict state guidelines .
- Fabric filters installed in 12 out of 13 MSW combustors that were tested during the period 1986 to 1989 achieved a particle emission rate some states such as California.

## **Design Criteria For Incineration Energy Recovery**

- A mature and well-functioning waste management system has been in place for a number of years.
- Incineration is especially relevant for the dry bin content in a 2-bin system. For Un segregated waste, pre-treatment is necessary.
- The lower calorific value (LCV) of waste must be at least 1450 kcal/kg (6MJ/kg) throughout all seasons. The annual average LCV must not be less than 1700 kcal/kg (7 MJ/ kg).
- The furnace must be designed in line with best available technologies to ensure stable and continuous operation and complete burn out of the waste and flue gases.
- The supply of combustible waste should be stable and amount to at least 500 tonnes/ day. Produced electricity and/ or steam can be sold at a sustainable basis (e.g. feeding into the general grid at adequate tariffs). It is possible to absorb the increased treatment cost through management charges, tipping fees.
- Skilled staff can be recruited and maintained.
- Since the capital investment is very high, the planning framework of the community should be stable enough to allow a planning horizon of 25 years or more.
- Pre-feasibility study for the technology led to positive conclusions for the respective community.
- Strict monitoring systems are proposed and monitored.