

**VISVESVARAYA TECHNOLOGICAL UNIVERSITY  
BELGAUM**



**ENGINEERING MECHANICS**

**(Subject Code: BCIVC203)**

**LECTURE NOTES**

**(MODULE-1)**

**II-SEMESTER**

**Mrs. Babitha B**

**Assistant Professor, Dept. of Civil Engineering**



**AJIET**

**A J INSTITUTE OF ENGINEERING & TECHNOLOGY**

DEPARTMENT OF CIVIL ENGINEERING

(A unit of Laxmi Memorial Education Trust. (R))

NH - 66, KottaraChowki, Kodical Cross - 575 006



## ENGINEERING MECHANICS

Subject Code: BCIVC203

Department: Civil Engineering

### MODULE-1

**Resultant of coplanar force system:** Basic dimensions and units, Idealisations, Classification of force system, principle of transmissibility of a force, composition of forces, resolution of a force, Free body diagrams, moment, Principle of moments, couple, Resultant of coplanar concurrent force system, Resultant of coplanar non-concurrent force system, Numerical examples.

### INTRODUCTION TO ENGINEERING MECHANICS

Mechanics is a physical science dealing with the study of response of body under the application of forces. Engineering mechanics is that branch of mechanics, it is broadly classified into three types

- Mechanics of Rigid bodies
- Mechanics of Deformable bodies
- Mechanics of Fluids

#### Mechanics of Rigid bodies:

It is the branch of science, which deals with the study of bodies which do not undergo any deformation under the application of forces.

It can further be classified as Statics and Dynamics

**Statics:** It is the branch of mechanics, which deals with the study of the behavior of bodies or particles in the state of rest.

#### Dynamics:

It is the branch of mechanics, which deals with the study of the behavior of bodies or particles in the state of motion.



## ENGINEERING MECHANICS

Subject Code: BCIVC203

Department: Civil Engineering

Dynamics is further divided into two types:

- a) Kinematics: The effect of forces are not considered
- b) Kinetics: The effect of forces are mainly considered

### Mechanics of Deformable bodies:

It is the branch of science which deals with the study of bodies which undergo deformation under the application of forces.

It is classified as

- a) Strength of materials
- b) Theory of plasticity
- c) Theory of elasticity

**Mechanics of Fluids:** It is the branch of science which deals with the study of fluids.

Fluids can be classified as

- a) Compressible Fluids
- b) Incompressible Fluids

**Idealization in Mechanics:** The mathematical description of a real engineering problem can become very complex. Thus, idealization (or models) and assumptions are used in mathematics in order to simplify the application of the theory.

**Particle:** It is a body having infinitely small volume and its mass can be neglected or it has a negligible dimensions.

In the mathematical sense, a particle is a body whose dimensions are considered to be near zero so that we may analyze it as a mass concentrated at a point. We often choose a particle as a differential element of the



## ENGINEERING MECHANICS

**Subject Code: BCIVC203**

**Department: Civil Engineering**

body. We may treat a body as a particle when its dimensions are irrelevant to the description of its position or the action of forces applied to it. A body considered as a particle is taken as a unique point, which is generally the mass center of the body. A particle has mass but no shape and dimensions. In so doing, the principles of mechanics are reduced to a rather simplified form, since the geometry of the body will not be involved in the analysis of the problem. The 1 line of actions of all the forces applied to the body must pass through this point. Forces can only exert push – pull effects on a particle.

**Rigid Body:** is an idealized body composed of a large number of particles all of which always remain at fixed distances from each other. In addition to the tendency to move a body in the direction of its application, a force may also tend to rotate a body about an axis. A rigid body is assumed to undergo no deformation under the action of applied forces. Its shape and dimensions remain fixed under all loading conditions and at all times.

**Point Force:** It is an idealized force assumed to act at a point on a body. A constant force exerted on a body by another is actually distributed over the area of contact between two bodies. If the area of contact is relatively small, the contact force between the two bodies may be considered as a point (concentrated) force.

**Continuum:** A continuous distribution of molecules in a body without intermolecular space is called a continuum.

### Technical terms used in Engineering Mechanics.

- 1. Particle:** A body of infinitely small volume whose mass can be neglected is called a particle.
- 2. Body:** Assemblage of a number of particles is known as a body.
- 3. Rigid body:** A rigid body is one in which the position of constituent particles do not change under the application of external force

## ENGINEERING MECHANICS

Subject Code: BCIVC203

Department: Civil Engineering

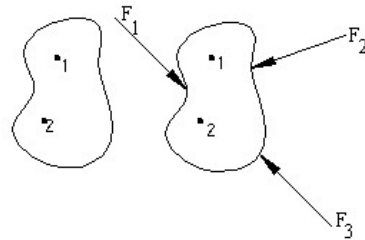

**4. Deformable body:** A deformable body is one in which the position of constituent particles changes under the application of external forces.

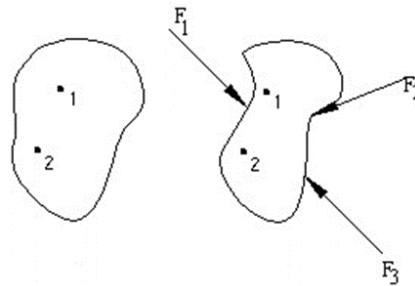

**5. Mass (m):** The total amount of matter present in the body is known as mass. Unit of mass is the kilogram-kg

**6. Weight:** A body is attracted towards the earth due to gravitation. This causes an acceleration directed towards the center of earth called acceleration due to gravity, denoted as 'g'. The resulting force is equal to the weight of body.

Weight=mass x acceleration due to gravity

$W=mg$  in Newton. Where  $g=9.81 \text{ m/s}^2$

**7. Scalar quantity:** A physical quantity, which has only magnitude, is called scalar quantity.

E.g. Time, mass, density, volume, distance.

## ENGINEERING MECHANICS

Subject Code: BCIVC203

Department: Civil Engineering

**8. Vector quantity:** A physical quantity, which has a direction in addition to magnitude, is known as vector quantity.

Eg. Force, displacement, velocity, acceleration.

**Newton's laws of motion:**

**Newton's First law:** This law states that 'everybody continues in its state of rest or of uniform motion along a straight line, so long as it is under the influence of a balanced force system'.

**Newton's Second law:** This law states that 'the rate of change momentum of a body is directly proportional to the impressed force and it takes place in the direction of force acting on it

**Newton's Third law:** This law states that 'action and reaction are equal in magnitude but opposite in direction'.

**Force:** It is the external agency, which tends to change the state of body or a particle. When a force is applied to the body which is at rest, the body may remain in the state of rest or it may move with some velocity. The SI unit of force is Newton.

**Elements of a Force or characteristics of a Force:**

A force can be identified by its four characteristics:

i) **Magnitude:** The length of the vector represents the magnitude of force. Ex: Force 10kN is the magnitude

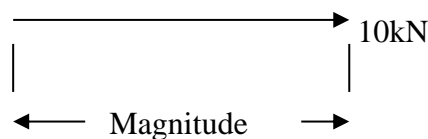

## ENGINEERING MECHANICS

Subject Code: BCIVC203

Department: Civil Engineering

ii) **Direction:** The direction of a force can be represented by an arrow head.

iii) **Line of action:** It is the line along which the force acts.

iv) **Point of application:** It is the point at which the force acts.

**Point force:** A force which is acting at a fixed point is known as a point force. Let us consider a man climbing a ladder. The weight of the man is not actually concentrated at a fixed point but for the purpose of analysis it is assumed to be concentrated at a particular point. Force is a vectore quantity with both magnitude and direction.

**Force System:** If two or more forces are acting on a body or a particle, then it is said to be a force system.

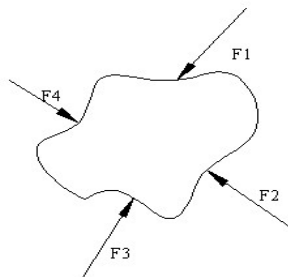

### Types of Force system:

- 1) Coplanar force system
- 2) Non-coplanar force system
- 3) Collinear force system

#### 1) Coplanar force system:

If two or more forces are acting in a single plane, then it is said to be a coplanar force system.

#### Types of Coplanar force system:

## ENGINEERING MECHANICS

Subject Code: BCIVC203

Department: Civil Engineering

- i) Coplanar concurrent force system.
- ii) Coplanar non-concurrent force system
- iii) Parallel force system.

If two or more forces are acting in a single plane and their lines of action pass through a single point, then it is said to be a **coplanar concurrent force system**

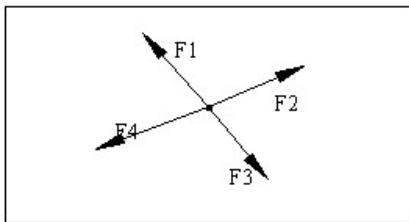

If two or more forces are acting in a single plane and their lines of action do not meet at a common point, then the forces constitute a **coplanar non-concurrent force system**.

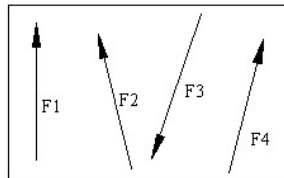

If two or more forces are acting in a single plane with their lines of action parallel to one another, produce a **coplanar parallel force system**.

Coplanar parallel force system is of two types:

- i) **Like parallel force system:** All the forces act parallel to one another and are in the same direction.

## ENGINEERING MECHANICS

Subject Code: BCIVC203

Department: Civil Engineering

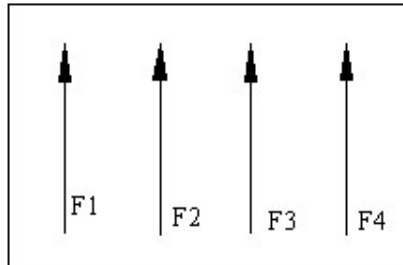

- ii) **Unlike parallel force system:** The forces act parallel to another, but some of the forces have their line of action in opposite directions.

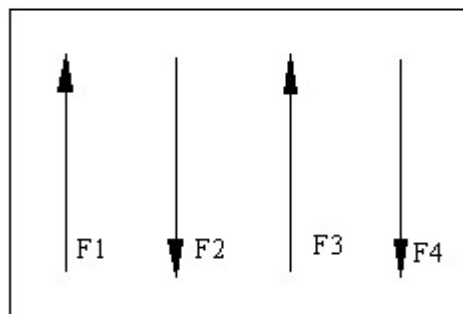

### 2) Non-coplanar force system:

If two or more forces are acting in different planes, the forces constitute a Non-coplanar force system. Such a system of forces can be

- i) Non coplanar concurrent force system.
- ii) Non coplanar non-concurrent force system.
- iii) Non coplanar parallel force system.

If a system has two or more forces acting on different planes but pass-through the same point, then it is said to be **non-coplanar concurrent force system**.

## ENGINEERING MECHANICS

Subject Code: BCIVC203

Department: Civil Engineering

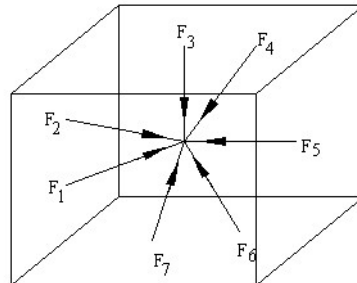

If two or more forces are acting on different planes and further do not pass through the same point, they cause a non-coplanar **non-concurrent force system**.

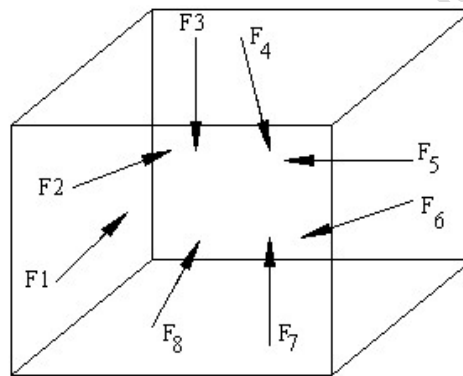

If two or more forces are acting in different planes and are parallel to one another, the system is said to be a **non-coplanar parallel force system**.

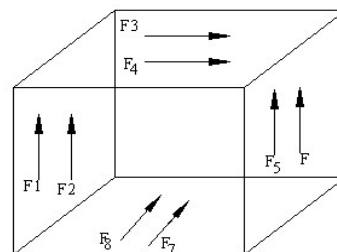

## ENGINEERING MECHANICS

Subject Code: BCIVC203

Department: Civil Engineering

### 3) Collinear force System:

If the lines of action of two or more forces coincide with one another, it is called a collinear force system.

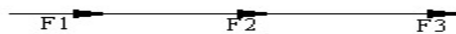

### Non-Collinear force System:

If the lines of action of the forces are not coinciding with one another, it is called a non-collinear force system.

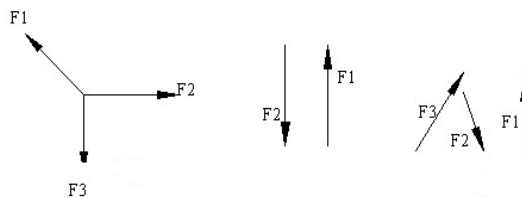

### Principle of Transmissibility of forces:

This principle states that 'a force can be transmitted from one point to another point along the same line of action such that the effect produced by the force on a body remains unchanged'.

**Explanation:** Let us consider a rigid body subjected to a force of  $F$  at point  $O$ . According to the principle of transmissibility this force can be transmitted to a new point  $O^1$  along the same line of action such that the net effect remains unchanged.

## **ENGINEERING MECHANICS**

**Subject Code: BCIVC203**

**Department: Civil Engineering**

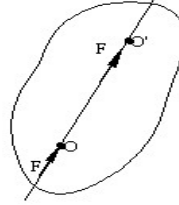

### **Principle of Superposition:**

This principle states that ‘the net effect of system of forces on a body is same as that of the combined effect of individual forces on the body’

### **Principle of physical Independence of forces:**

This principle states that ‘the action of a force on a body is not affected by the action of any other force on the body’.

### **RESULTANT FORCE OF A SYSTEM OF FORCES**

The resultant of a system of forces is a single calculated force which is capable of producing the same effect as that of system of forces on the body. It is the vector sum of forces of the system.

### **COMPOSITION OF FORCES**

The technique of finding the resultant of forces is called composition of forces.

### **LAW OF PARALLELOGRAM OF FORCES:**

If two forces, which act at a point be represented in magnitude and direction by the two adjacent sides of a parallelogram drawn from one of its angular points, their resultant is represented by the diagonal of the parallelogram passing through that angular point, in magnitude and direction.

## ENGINEERING MECHANICS

Subject Code: BCIVC203

Department: Civil Engineering

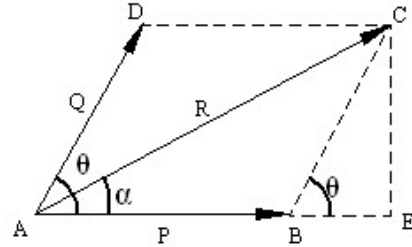
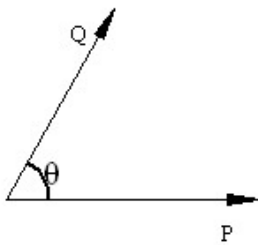

If two forces are acting simultaneously on a particle and away from the particle, with the two adjacent sides of a parallelogram representing both the magnitude and direction of forces, the magnitude and direction of a resultant can be represented by the diagonal of the parallelogram starting from common point of two forces.

Let P and Q are the two forces, which are represented by sides AB and AD of the parallelogram, and resultant can be represented by AC

To find the magnitude R of the resultant, consider the  $\Delta CAE$ , where

$$\begin{aligned} AC^2 &= AE^2 + CE^2 \\ &= (AB + BE)^2 + (CE)^2 \end{aligned}$$

Consider the  $\Delta CBE$ , where

$$CE = Q \sin \theta$$

$$BE = Q \cos \theta$$

$$AC^2 = AB^2 + 2AB \cdot BE + BE^2 + CE^2$$

$$R^2 = P^2 + 2 \cdot P \cdot Q \cos \theta + Q^2 \cos^2 \theta + Q^2 \sin^2 \theta$$

$$= P^2 + Q^2 + 2PQ \cos \theta$$

$$R = \sqrt{P^2 + Q^2 + 2PQ \cos \theta}$$

To find the direction  $\alpha$  of the resultant, consider the  $\Delta CAE$ , where

## ENGINEERING MECHANICS

Subject Code: BCIVC203

Department: Civil Engineering

$\triangle CAE$

$$\tan \alpha = \frac{CE}{AB + BE}$$

$$= \frac{Q \sin \theta}{P + Q \cos \theta}$$

$$\therefore \alpha = \tan^{-1} \left( \frac{Q \sin \theta}{P + Q \cos \theta} \right)$$

ii) Triangle law:

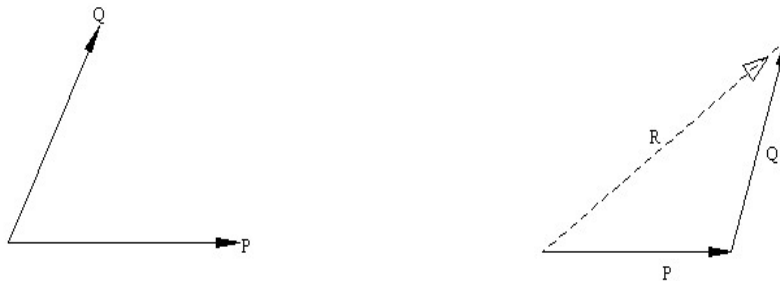

If two forces acting simultaneously on a particle can be represented both in magnitude and direction by the two sides of a triangle taken in order, the magnitude and direction of a resultant can be represented by the third side of a triangle, taken in opposite order.

iii) Polygon law:

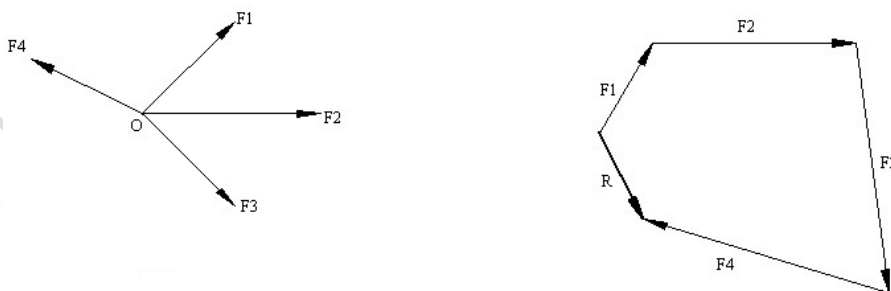

## ENGINEERING MECHANICS

Subject Code: BCIVC203

Department: Civil Engineering

If a number of forces are acting on a particle, can be represented by both magnitude and direction by sides of polygon taken in order, the resultant can be represented in magnitude and direction by the closing side of a polygon taken in the opposite order.

### PRINCIPLE OF RESOLVED PARTS

- The components of each force in the system in two mutually perpendicular directions are found.
- The components in each direction are algebraically added to obtain the two components
- These two component forces which are mutually perpendicular are combined to obtain the resultant force.

If two or more forces are acting in a single plane and passing through a single point, such a force system is known as a coplanar concurrent force system

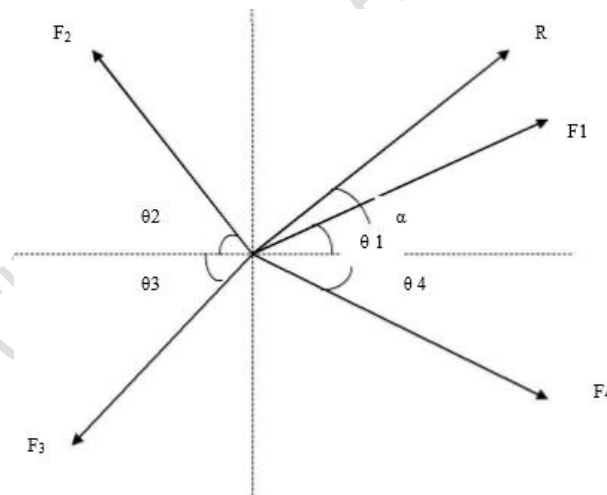

Let  $F_1, F_2, F_3, F_4$  represent a coplanar concurrent force system. It is required to determine the resultant of this force system.

It can be done by first resolving or splitting each force into its component forces in each direction are then algebraically added to get the sum of component forces.

## ENGINEERING MECHANICS

Subject Code: BCIVC203

Department: Civil Engineering

These two sums are then combined using parallelogram law to get the resultant of the force systems.

In the fig, let  $f_{x1}, f_{x2}, f_{x3}, f_{x4}$  be the components of  $F_1, F_2, F_3, F_4$  forces in the X-direction.

Let  $\sum F_x$  be the algebraic sum of component forces in x-direction

$$\sum F_x = f_{x1} + f_{x2} + f_{x3} + f_{x4}$$

Similarly Let  $\sum F_y$  be the algebraic sum of component forces in Y-direction

$$\sum F_y = f_{y1} + f_{y2} + f_{y3} + f_{y4}$$

### Resolution of force:

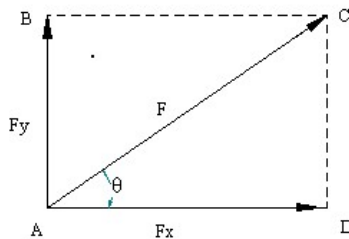

The process of splitting of a force into **its two rectangular components** is known as resolution of force.

In the above figure,  $F$  is the force which makes an angle  $\theta$  with the horizontal, can be resolved into two components namely  $F_x$  and  $F_y$  along x and y axis respectively

In  $\Delta^{\text{le}} CAD$ ,  $\cos\theta = F_x/F \Rightarrow F_x = F\cos\theta$

$$\sin\theta = F_y/F \Rightarrow F_y = F\sin\theta$$

## ENGINEERING MECHANICS

Subject Code: BCIVC203

Department: Civil Engineering

If  $\theta$  is the angle made by the force with vertical

$$F_Y = F \cos \theta ; F_X = F \sin \theta$$

**Note:** If the force makes an angle of  $\theta$  with horizontal, the horizontal component of the force is  $F \cos \theta$

### Composition of Forces:

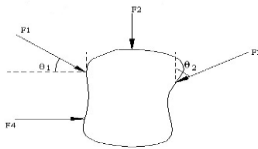

The process of combining a number of forces in to a single force such that the net effect produced by the single force must be equal to the algebraic sum of effect produced by the individual forces.

**Resultant force:** If number of forces are acting on a body, they can be replaced by a single force called the resultant force which produces the same effect on the body as that produced by the individual forces acting together.

$\Sigma F_X$  = Algebraic sum of the components of the forces along x axis

$$\Sigma F_X = F_4 + F_1 \cos \theta_1 - F_3 \sin \theta_2$$

$\Sigma F_Y$  = Algebraic sum of the components of the forces along y axis

$$\Sigma F_Y = -F_2 - F_1 \sin \theta_1 - F_3 \cos \theta_2$$

## ENGINEERING MECHANICS

Subject Code: BCIVC203

Department: Civil Engineering

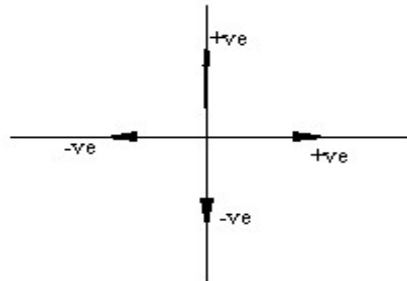

### PROBLEMS:

1. A Force of 200N is acting on a block as shown in figure. Find the component of force along the horizontal and vertical axis.

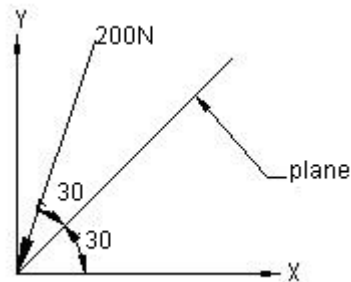

$$F_x = -200 \cos 60^\circ = 100\text{N}$$

$$F_y = -200 \sin 60^\circ = -173.2\text{N}$$

### PROBLEMS:

2) Determine the magnitude & direction of the resultant (R) of the coplanar concurrent force system shown in figure below.

## ENGINEERING MECHANICS

Subject Code: BCIVC203

Department: Civil Engineering

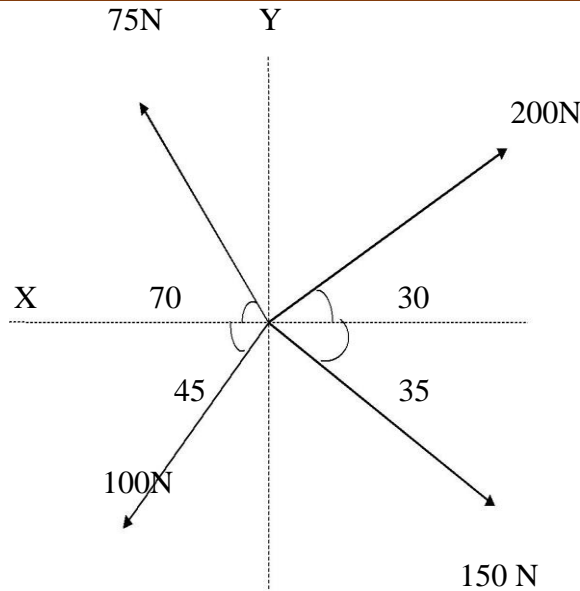

Let  $R$  be the given resultant force system

Let  $\alpha$  be the angle made by the resultant with x- direction.

$$\sum F_x = 200\cos 30^\circ - 75\cos 70^\circ - 100\cos 45^\circ + 150\cos 35^\circ$$

$$\sum F_x = 199.7\text{N}$$

$$\sum F_y = 200\sin 30^\circ + 75\sin 70^\circ - 100\sin 45^\circ - 150\sin 35^\circ$$

$$\sum F_y = 13.72\text{ N}$$

$$R = \sqrt{(\sum F_x)^2 + (\sum F_y)^2}$$

$$R = 200.21\text{N}$$

$$\alpha = \tan^{-1}\left(\frac{\sum F_y}{\sum F_x}\right)$$

$$\alpha = \tan^{-1}(13.72/ 199.72) = 3.93^\circ$$

**ENGINEERING MECHANICS**

Subject Code: BCIVC203

Department: Civil Engineering

3. Determine the resultant of the concurrent force system shown in figure

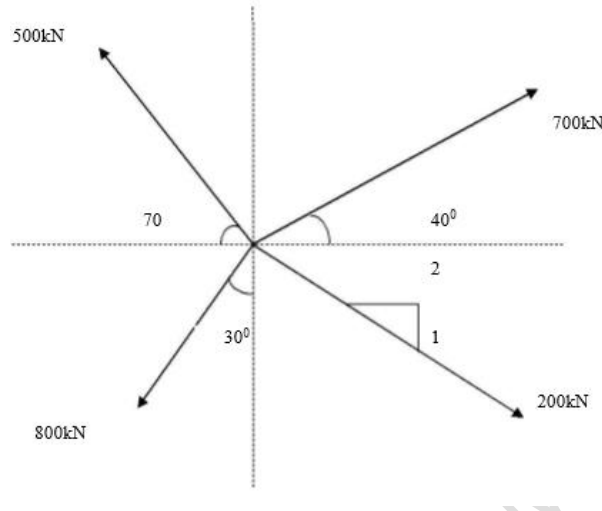

Let R be the given resultant force system

Let  $\alpha$  be the angle made by the resultant with x- direction.

$$\sum F_x = 700\cos 40^\circ - 500\cos 70^\circ - 800\sin 30^\circ + 200\cos 26.56^\circ$$

$$\sum F_x = 144.11 \text{ kN}$$

$$\sum F_y = 700\sin 40^\circ + 500\sin 70^\circ - 800\cos 30^\circ - 200\sin 26.56^\circ$$

$$\sum F_y = 137.55 \text{ kN}$$

$$R = \sqrt{(\sum F_x)^2 + (\sum F_y)^2}$$

$$R = 199.21 \text{ N}$$

$$\alpha = \tan^{-1}\left(\frac{\sum F_y}{\sum F_x}\right)$$

$$\alpha = \tan^{-1}(137.55/ 144.11) = 43.66$$

4.) Determine the resultant of a coplanar concurrent force system shown in figure below

## ENGINEERING MECHANICS

Subject Code: BCIVC203

Department: Civil Engineering

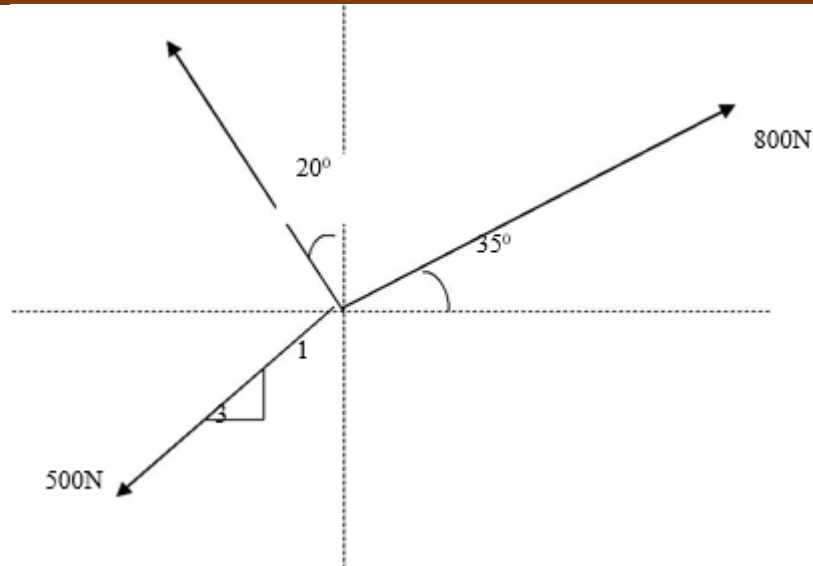

Let R be the given resultant force system

Let  $\alpha$  be the angle made by the resultant with x- direction.

$$\sum F_x = 800\cos 35^\circ - 100\sin 20^\circ + 500\cos 60^\circ + 0$$

$$\sum F_x = 1095.48 \text{ N}$$

$$\sum F_y = 800\sin 35^\circ + 100\cos 20^\circ - 500\sin 60^\circ - 600$$

$$\sum F_y = 110.90 \text{ N}$$

$$R = \sqrt{(\sum F_x)^2 + (\sum F_y)^2}$$

$$R = 1101.08 \text{ N}$$

$$\alpha = \tan^{-1}\left(\frac{\sum F_y}{\sum F_x}\right)$$

$$\alpha = \tan^{-1}(110.90/1095.48) = 5.78^\circ$$

5. The Magnitude and direction of the resultant of the coplanar concurrent force system shown in figure.

## ENGINEERING MECHANICS

Subject Code: BCIVC203

Department: Civil Engineering

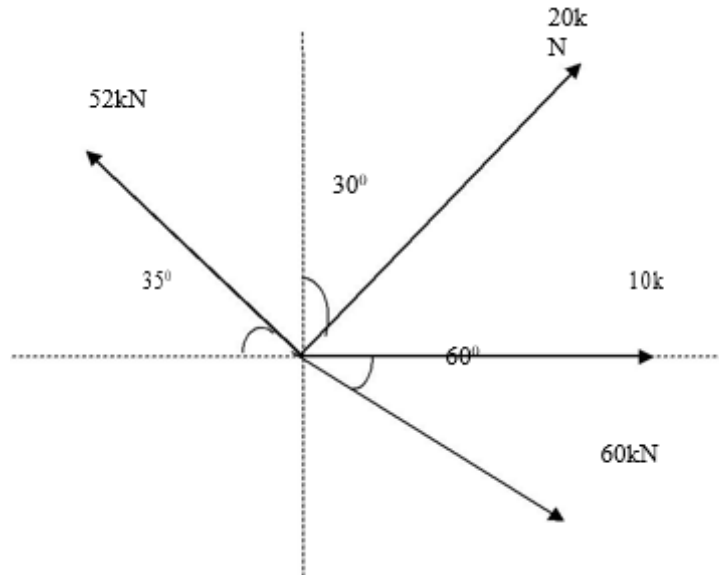

Let R be the given resultant force system

Let  $\alpha$  be the angle made by the resultant with x- direction.

$$\sum F_x = 20\sin 30^\circ - 52\cos 35^\circ + 60\cos 60^\circ + 10$$

$$\sum F_x = \mathbf{7.404 \text{ kN}}$$

$$\sum F_y = 20\cos 30^\circ + 52\sin 35^\circ - 60\sin 60^\circ + 0$$

$$\sum F_y = \mathbf{-4.815 \text{ kN}}$$

$$R = \sqrt{(\sum F_x)^2 + (\sum F_y)^2}$$

$$\mathbf{R = 8.831 \text{ kN}}$$

$$\alpha = \tan^{-1}\left(\frac{\sum F_y}{\sum F_x}\right)$$

$$\alpha = \tan^{-1}(4.815 / 7.404) = 33.03^\circ$$

**ENGINEERING MECHANICS**

Subject Code: BCIVC203

Department: Civil Engineering

6) 26kN force is the resultant of two forces, one of which is as shown in figure. Determine the other force.

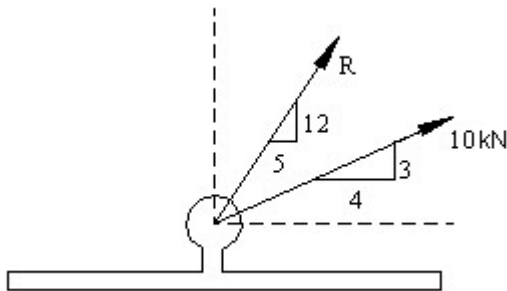

Let P be the unknown force, which makes an angle of  $\theta$  with horizontal.

$$R = 26 \text{ kN}$$

$$\theta_1 = \tan^{-1}\left(\frac{12}{5}\right) = 67.38^\circ \quad \theta_2 = \tan^{-1}\left(\frac{3}{4}\right) = 36.87^\circ$$

$$\sum F_x = R_x$$

$$P \cos \theta + 10 \cos 36.87^\circ = 26 \cos 67.38^\circ$$

$$P \cos \theta = 26 \cos 67.38^\circ - 10 \cos 36.87^\circ = 2 \text{ -----(1)}$$

$$\sum F_y = R_y$$

$$P \sin \theta + 10 \sin 36.86^\circ = 26 \sin 67.38^\circ$$

$$P \sin \theta = 26 \sin 67.38^\circ - 10 \sin 36.86^\circ = 18 \text{ -----(2)}$$

Eqn.(2) / Eqn. (1) gives

## ENGINEERING MECHANICS

Subject Code: BCIVC203

Department: Civil Engineering

$$\frac{p \sin \theta}{p \cos \theta} = \frac{18}{2}$$

$$\tan \theta = 9$$

$$\theta = \tan^{-1}(9) = 83.66^\circ$$

Squaring (1) and (2) and then adding

$$p^2 \sin^2 \theta + p^2 \cos^2 \theta = 4 + 324$$

$$p^2 \sin^2 \theta + p^2 \cos^2 \theta = 328$$

$$p^2 = 328$$

$$p = 18.11 \text{ kN}$$

7) 3 forces acting on a hook are shown in the figure. Determine the direction of fourth force of magnitude 120N such that the hook is pulled in X-direction. Determine the resultant force in X direction.

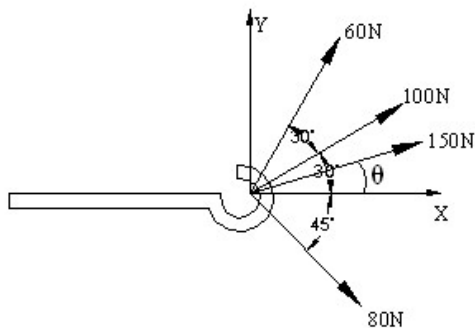

$$\sum F_x = R$$

$$\sum F_y = 0$$

$$\sum F_y = 0$$

## ENGINEERING MECHANICS

Subject Code: BCIVC203

Department: Civil Engineering

$$\Rightarrow -80 \sin 45^\circ + 60 \sin 60^\circ + 100 \sin 30^\circ + 150 \sin \theta = 0$$

$$150 \sin \theta = 45.39$$

$$\theta = \sin^{-1} \left( \frac{45.39}{150} \right) = 17.61^\circ$$

$$\sum F_x = R$$

$$\text{ie. } 80 \cos 45^\circ + 60 \cos 60^\circ + 100 \cos 30^\circ + 150 \cos 17.61^\circ = R$$

$$R = 316.142 \text{ N.}$$

8) Four forces are acting on a bolt shown in figure. Determine the magnitude and direction of the resultant.

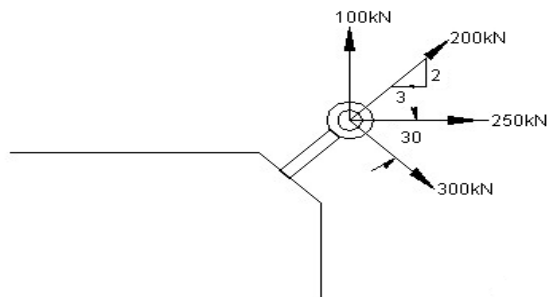

Magnitude of resultant (R)

$$R = \sqrt{\sum F_x^2 + \sum F_y^2}$$

$$\sum F_x = 250 + 300 \cos 30^\circ + 200 \cos 33.69^\circ = 676.218$$

$$\sum F_y = 100 - 300 \sin 30^\circ + 200 \sin 33.69^\circ = 60.939$$

$$R = \sqrt{(676.218)^2 + (60.939)^2} = 678.958 \text{ kN.}$$

## ENGINEERING MECHANICS

Subject Code: BCIVC203

Department: Civil Engineering

Direction of resultant ( $\theta$ )

$$\theta = \tan^{-1} \left( \frac{\sum FY}{\sum Fx} \right)$$

$$\theta = \tan^{-1} \left( \frac{60.939}{676.218} \right) = 5.149^\circ$$

**Moment of a force:**

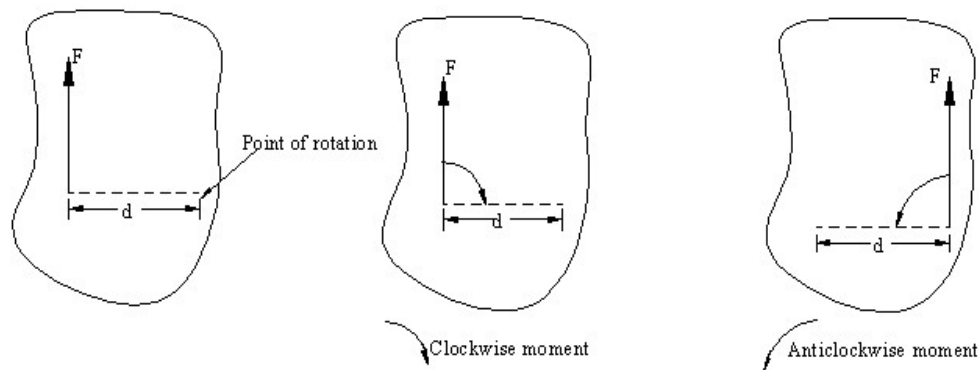

The turning effect produced by the force on a body is known as moment of a force. The magnitude of the moment is given by the product of magnitude of force and perpendicular distance between the line of action of force and point or axis of rotation.

**Types of moment:**

- i) **Clockwise moment:** If the tendency of force is rotate the body in clockwise direction, (then) it is said to be a clockwise moment and is taken positive.

**ENGINEERING MECHANICS**

**Subject Code: BCIVC203**

**Department: Civil Engineering**

- ii) Anticlockwise moment: If the tendency of force is to rotate the body in anticlockwise direction, it is said to be anticlockwise moment and is taken negative.

**Properties of couple:**

- i) Two equal and opposite parallel forces are required to form a couple.
- ii) Magnitude of the moment of the couple=Product of magnitude of one of the force and moment arm (perpendicular distance between two forces).
- iii) Resultant of the forces of the couple is zero.

**Types of couple:**

- i) Clockwise couple
- ii) Anticlockwise couple

**Varignon’s Theorem of moment:** This is also known as principle of moments

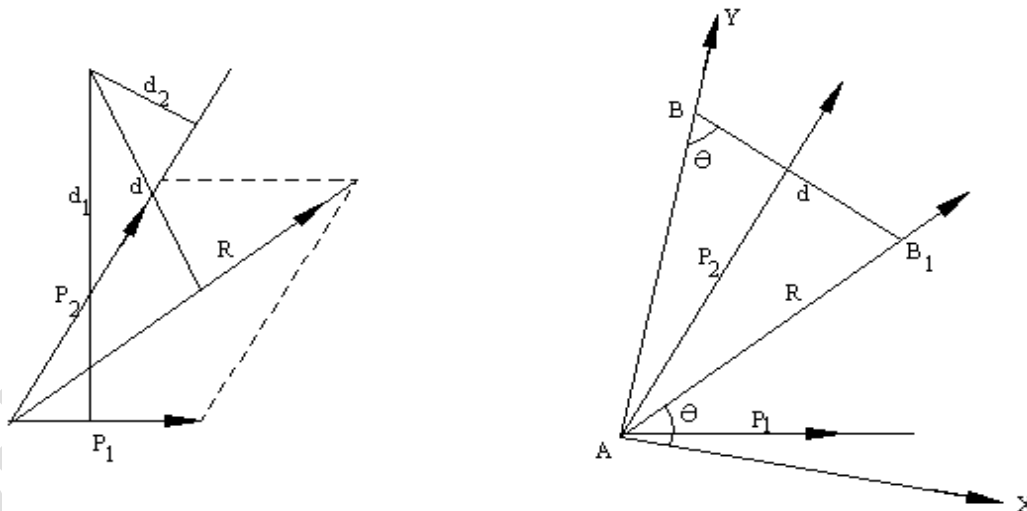

The theorem states that “Algebraic sum of moments of individual forces of a force system about a point is equal to moment of their resultant about the same point.



**ENGINEERING MECHANICS**

**Subject Code: BCIVC203**

**Department: Civil Engineering**

Let R be the resultant of forces P<sub>1</sub> and P<sub>2</sub> and B be the moment centre. Let d, d<sub>1</sub> and d<sub>2</sub> be the moment arms of forces R, P<sub>1</sub> and P<sub>2</sub> respectively from the moment centre B.

We have to prove that;

$$Rd = P_1d_1 + P_2d_2$$

**Proof:**

Join AB and consider it as Y axis and draw X axis at right angles to it at A. Let θ be the angle made by the R with X axis and noting that same angle is formed by the perpendicular to R from B and note the point as B<sub>1</sub>.

We know that, Rd = R<sub>x</sub>ABcosθ

$$= AB \times R \cos \theta$$

$$Rd = AB \times R_x \dots\dots\dots (1)$$

Where R<sub>x</sub> be the component of R in X direction. Similarly, if P<sub>1x</sub> and P<sub>2x</sub> are the components of P<sub>1</sub> and P<sub>2</sub> in X direction respectively, then;

$$P_1d_1 = AB \times P_{1x} \dots\dots\dots (2)$$

$$\text{And } P_2d_2 = AB \times P_{2x} \dots\dots\dots (3)$$

Adding eqns. (2) and (3), we get

$$P_1d_1 + P_2d_2 = AB (P_{1x} + P_{2x})$$

$$P_1d_1 + P_2d_2 = AB \times R_x \dots\dots\dots (4)$$

Since the sum of X components of individual forces is equal to the X components of the resultant R. From eqn. (1) and (4) we can conclude that

$$\mathbf{Rd = P_1 d_1 + P_2 d_2}$$

## ENGINEERING MECHANICS

Subject Code: BCIVC203

Department: Civil Engineering

### Problems:

1) A 100N vertical force is applied to a shaft at A as shown in figure. Determine the effect of 100N force at O.

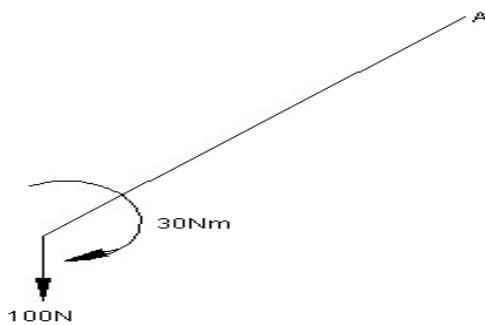
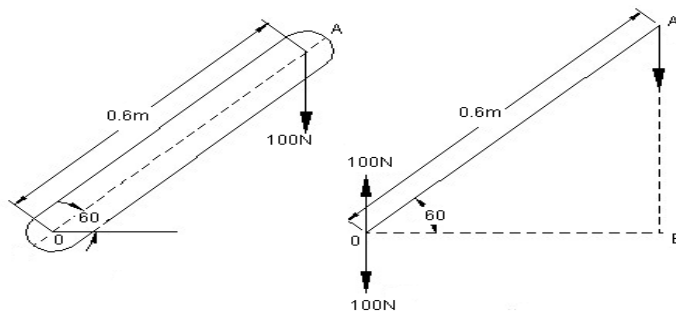

Apply equal and opposite force of 100N at O.

The effect of 100N force at O is,

It produces as

- (a) Downward force 100N at O
- (b) Clockwise couple of  $100 \times 0.3 = 30\text{Nm}$

2) Reduce the force acting at A into a system of force and couple at point O.

## ENGINEERING MECHANICS

Subject Code: BCIVC203

Department: Civil Engineering

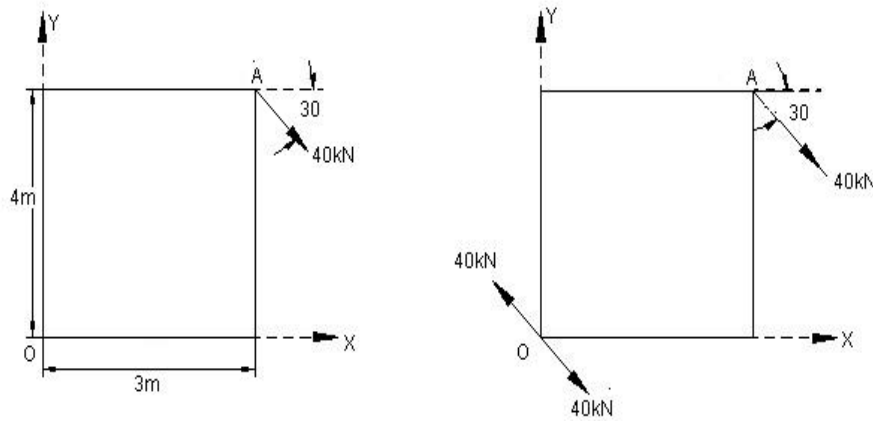

Apply equal and opposite forces of 40kN at O parallel to given force

Couple at point O =  $M_0 = 40\cos 30 \times 4 + 40\sin 30 \times 3 = 198.56 \text{ kNm}$ , clockwise.

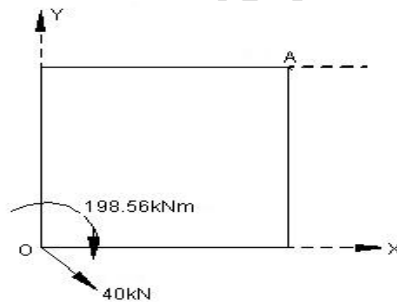

3) For the system of parallel forces shown below, determine the magnitude of the resultant and also its position from A.

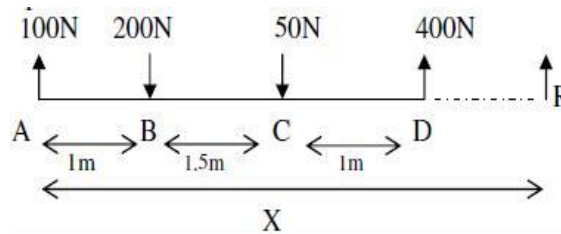

$$\sum F_y = +100 - 200 - 50 + 400 = +250 \text{ N} \uparrow$$

## ENGINEERING MECHANICS

Subject Code: BCIVC203

Department: Civil Engineering

$$R = \sum F_y = 250\text{N}$$

Since  $\sum F_x = 0$

Taking moments of forces about A and applying varignon's principle of moments

$$-250 \times x = -400 \times 3.5 + 50 \times 2.5 + 200 \times 1$$

$$= -1075 / -250 = 4.3\text{m}$$

4) The three like parallel forces 100 N, F and 300 N are acting as shown in figure below. If the resultant  $R=600$  N and is acting at a distance of 4.5 m from A, find the magnitude of force F and position of F with respect to A.

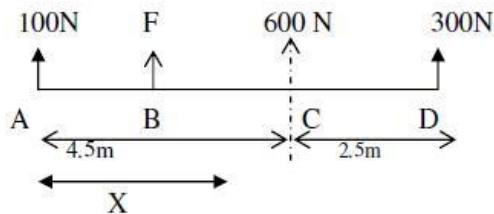

Let  $x$  be the distance from A to the point of application of force F

Here  $R = \sum F_y$

$$600 = 100 + F + 300$$

$$= 200 \text{ N}$$

Taking moments of forces about A and applying varignons principle of moments,

We get

$$-600 \times 4.5 = -300 \times 7 - 200 \times x$$

## ENGINEERING MECHANICS

Subject Code: BCIVC203

Department: Civil Engineering

$$= 600 \times 4.5 - 300 \times 7$$

$$X = 600/200 = \mathbf{3\text{m from A}}$$

5. A bracket is subjected to five forces and a couple as shown in figure. Determine magnitude, direction and line of action of resultant.

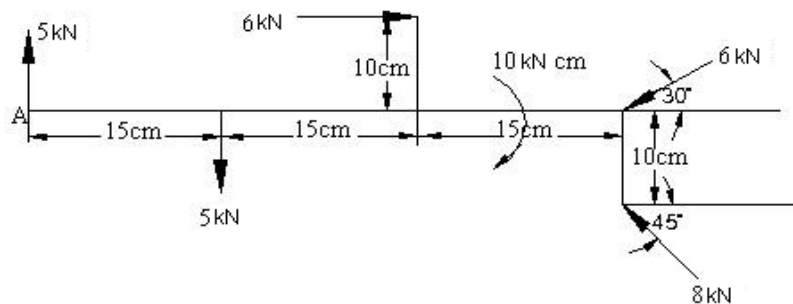

$$R = \sqrt{\sum F_x^2 + \sum F_y^2}$$

$$\sum F_x = 6 - 6 \cos 30^\circ - 8 \cos 45^\circ = -4.853 \text{ kN}$$

$$\sum F_y = 5 - 6 \sin 30^\circ + 8 \sin 45^\circ - 5 = 2.656 \text{ kN}$$

$$R = \sqrt{\sum F_x^2 + \sum F_y^2}$$

$$R = \sqrt{(-4.853)^2 + (2.656)^2} = 5.532 \text{ kN}$$

$$\theta = \tan^{-1} \frac{\sum F_y}{\sum F_x}$$

$$= 28.69^\circ$$

Line of action: Here we can take moment about any point

## ENGINEERING MECHANICS

Subject Code: BCIVC203

Department: Civil Engineering

$$d = \frac{\sum M_A}{R}$$

$$\sum M_A = 5 \times 15 + 6 \times 10 + 6 \sin 30^\circ \times 45 + 8 \cos 45^\circ \times 10 - 8 \sin 45^\circ \times 45 + 10 = 82 \text{KNcm}$$

$$d = \left| \frac{82}{5.532} \right| = 14.825 \text{cm}$$

$$\text{X-intercept} = \left| \frac{\sum M_A}{F_y} \right| = \left| \frac{82}{2.656} \right| = 30.873 \text{cm}$$

$$\text{Y-intercept} = \left| \frac{\sum M_A}{F_x} \right| = \left| \frac{82}{-4.853} \right| = 16.897 \text{cm}$$

Calculation of equivalent force couple at A means calculation of R and  $M_A$

6. Determine the resultant of the force system acting on the plate. As shown in figure given below with respect to AB and AD.

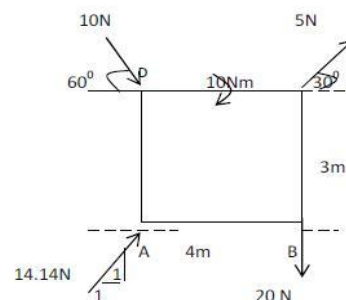

$$\sum F_x = 5 \cos 30^\circ + 10 \cos 60^\circ + 14.14 \cos 45^\circ = \mathbf{19.33 \text{N}}$$

$$\sum F_y = 5 \sin 30^\circ - 10 \sin 60^\circ + 14.14 \sin 45^\circ = \mathbf{-16.16 \text{N}}$$

$$R = \sqrt{(\sum F_x)^2 + (\sum F_y)^2} = \mathbf{25.2 \text{N}}$$

**ENGINEERING MECHANICS**

Subject Code: BCIVC203

Department: Civil Engineering

$$\theta = \tan^{-1}(\frac{\sum F_y}{\sum F_x})$$

$$\theta = \tan^{-1}(16.16/19.33) = 39.89^\circ$$

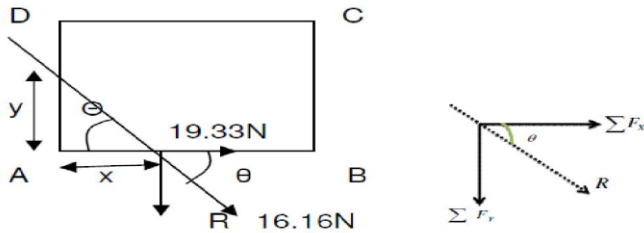

Tracing moments of forces about A and applying varignon's principle of moments we get

$$+16.16X = 20 \times 4 + 5 \cos 30^\circ \times 3 - 5 \sin 30^\circ \times 4 + 10 + 10 \cos 60^\circ \times 3$$

$$x = 107.99/16.16 = 6.683m$$

$$\text{Also, } \tan 39.89 = y/6.83$$

$$= 5.586m.$$

7. Determine the resultant of system of forces shown in figure acting on a 40mm×40mm size lamina in the figure. Each grid is of size 10mm×10mm. Determine x and y intercept also.

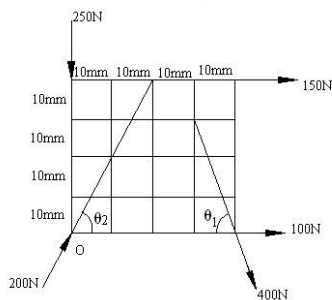

$$\tan \theta_2 = \left(\frac{40}{20}\right) ; \quad \theta_2 = \tan^{-1}(2) = 63.43^\circ \quad \tan \theta_1 = \frac{30}{10} ; \quad \theta_1 = \tan^{-1}(3) = 71.57^\circ$$

## ENGINEERING MECHANICS

Subject Code: BCIVC203

Department: Civil Engineering

$$R = \sqrt{\sum F_x^2 + \sum F_y^2}$$

$$\sum F_x = 150 + 400 \cos 71.57^\circ + 200 \cos 63.43 + 100 = 465.982 N$$

$$\sum F_y = -250 - 400 \sin 71.56^\circ + 200 \sin 63.43 = -450.61 N$$

$$R = \sqrt{\sum F_x^2 + \sum F_y^2} = 648.219 N$$

$$\theta = \tan^{-1} \frac{\sum F_y}{\sum F_x} = -44.04^\circ$$

$$\text{X-intercept} = \left| \frac{\sum M}{\sum F_y} \right|$$

$$\sum M = 0 + 150 \times 40 + 400 \sin 71.56^\circ \times 40$$

$$= 21178.487 \text{ Nmm}$$

$$x - \text{intercept} = \left| \frac{21178.487}{-450.61} \right| = 47 \text{ mm}$$

$$y - \text{intercept} = \left| \frac{21178.487}{365.9821} \right| = 45.449 \text{ mm}$$

8. 4 forces acts on a 700mm×375mm plate

a) Find the resultant of these forces b) locate the point where the line of action of the resultant intersects the edge AB of the plate.

## ENGINEERING MECHANICS

Subject Code: BCIVC203

Department: Civil Engineering

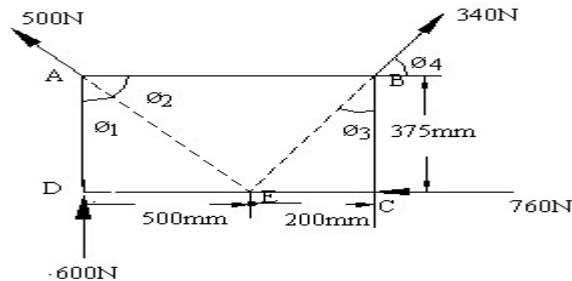

$$\tan \phi_1 = \frac{500}{375},$$

$$\phi_1 = 53.13$$

$$\phi_2 = 90 - 53.13 = 36.87$$

$$\tan \phi_3 = \frac{200}{375} = 28.072$$

$$\tan \phi_4 = 90 - 28.072 = 61.928$$

$$R = \sqrt{\sum F_x^2 + \sum F_y^2}$$

$$\sum F_x = -760 + 340 \cos 61.928^\circ - 500 \cos 36.87 = -1000\text{N}$$

$$\sum F_y = 600 + 500 \sin 36.87^\circ + 340 \sin 61.928 = 1200\text{N}$$

$$R = \sqrt{\sum F_x^2 + \sum F_y^2} = 1562.05 \text{ N}$$

$$\theta_1 = \tan^{-1}\left(\frac{1200}{1000}\right) = 50.19^\circ$$

$$\text{ii) x-intercept} = \left| \frac{\sum M_A}{\sum F_y} \right|$$

$$\sum M_A = 760 \times 375 + 340 \sin 61.928^\circ \times 700 + 0 = 74999.048\text{Nm}$$

## ENGINEERING MECHANICS

Subject Code: BCIVC203

Department: Civil Engineering

$$X \text{ intercept} = \left| \frac{74999.048}{1200} \right| = 62.499 \text{ mm}$$

The resultant intersects the edge AB at a distance of 62.499mm from point A

9. The forces acting on 1m length of a dam are shown in fig, Determine the resultant of the three forces acting on the dam shown in Fig. and locate its intersection with the base OB. For good design, this intersection should occur within the middle third of the base. Does it?

$$R_x = \sum F_x$$

$$R_x = 50 - 30 \cos 30^\circ$$

$$R_x = 24.02 \text{ kN to the right}$$

$$R_y = \sum F_y$$

$$R_y = -120 - 30 \sin 30^\circ$$

$$R_y = -135 \text{ kN downward}$$

$$R = \sqrt{R_x^2 + R_y^2}$$

$$R = 137.12 \text{ kN}$$

$$\tan \theta_x = R_y / R_x$$

$$\tan \theta_x = 135 / 24.02$$

$$\theta_x = 79.92^\circ$$

taking moment about the point O,

$$50(2) + 120(2) - (30 \cos 30^\circ)(1.25 \sin 60^\circ) + (30 \sin 30^\circ)(6 - 1.25 \cos 60^\circ) = -135(x)$$

$$x = 2.861 \text{ m}$$

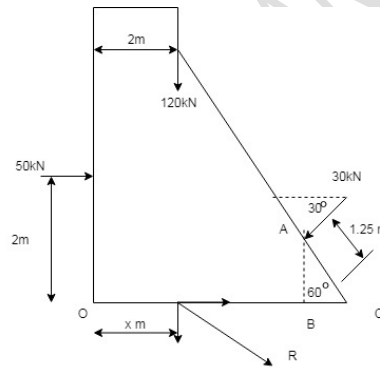

## ENGINEERING MECHANICS

Subject Code: BCIVC203

Department: Civil Engineering

### REVIEW QUESTIONS:

1. Explain the basic Idealization in mechanics
2. Define couple and list out the characteristics of couple
3. What are the characteristics of a force
4. Define the principle of superposition of forces
5. State and explain principle of transmissibility of forces.
6. List the various system of forces with their characteristics and an example with a neat sketch.
7. The moment of a certain force is 240N-m anticlockwise about point O as shown in fig and 320N-m clockwise about point B. If the moment of force about A is zero. Determine the magnitude and direction of force

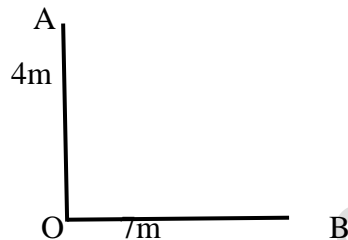

8. A 500N force is applied to a point A of L shaped plate. Find the equivalent force couple system at B

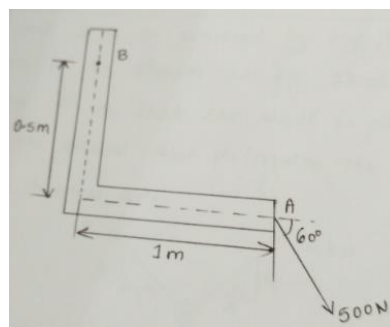

- 19.) Determine the resultant of a coplanar concurrent force system shown in figure below

## ENGINEERING MECHANICS

Subject Code: BCIVC203

Department: Civil Engineering

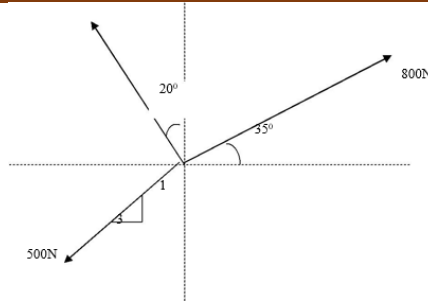

20) Four forces act on 700mm\*375mm plate.

- Find the resultant of these forces.
- Locate the point where the line of action intersect edge AB of the plate.

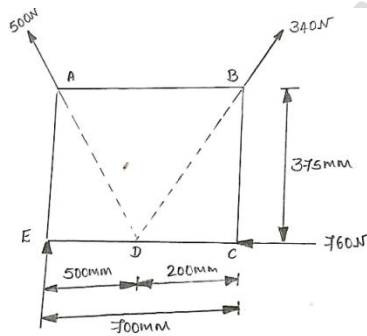

20. Find the magnitude, direction and x-intercept of the resultant of the system of forces as shown in fig, S is the midpoint of RT.

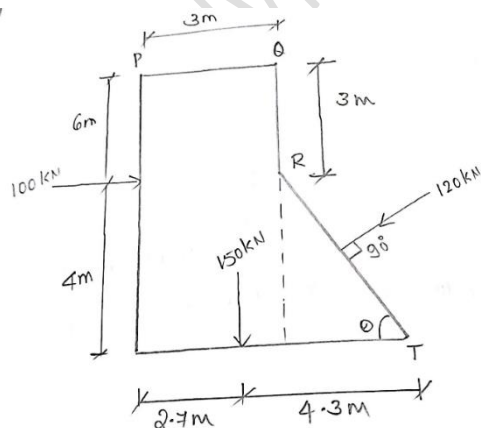

21. State and prove Lami's theorem.

## ENGINEERING MECHANICS

Subject Code: BCIVC203

Department: Civil Engineering

22. State and explain principle of resolved parts.

23. The force system as shown in fig has a resultant of 240 acting up along the Y axis.

Compute the value of force P and its inclination with x axis.

