



MODULE -3- PART 1

Contours - Definition, terms used, characteristics of contours and applications of contours in civil engineering practice. Contouring using level, theodolite, and total station. Plotting of contours in CAD.

CONTOURS

The value of plan or map is highly enhanced if the relative position of the points is represented both horizontally as well as vertically. Such maps are known as topographic maps. Thus, in a topographic survey, both horizontal as well as vertical control are required. On a plan, the relative altitudes of the points can be represented by shading, hachures, form lines or contour lines. Out of these, contour lines are most widely used because they indicate the elevations directly.

Contour

A contour is an imaginary line on the ground joining the points of equal elevation. It is a line in which the surface of ground is intersected by a level surface. A contour line is a line on the map representing a contour. Fig. 5.16 shows a pond with water at an elevation of 101.00 m as shown in the plan by the water mark. If the water level is now lowered by 1 m, another water mark representing 100.00 m elevation will be obtained. These water marks may be surveyed and represented on the map in the form of contours.

A topographic map presents a clear picture of the surface of the ground. If a map is to a big scale, it shows where the ground is nearly level, where it is sloping, where the slopes are steep and where they are gradual. If a map is to a small scale, it shows the flat country, the hills and valleys, the lakes and water courses and other topographic features.

Contour Interval

The difference in elevation between successive contour lines on a given map is fixed. This vertical distance between any two contour lines in a map is called the contour interval (C.I.) of the map. Figure 3.1(a) shows contour interval of 1m whereas Figure 3.1 (b) shows 10m.

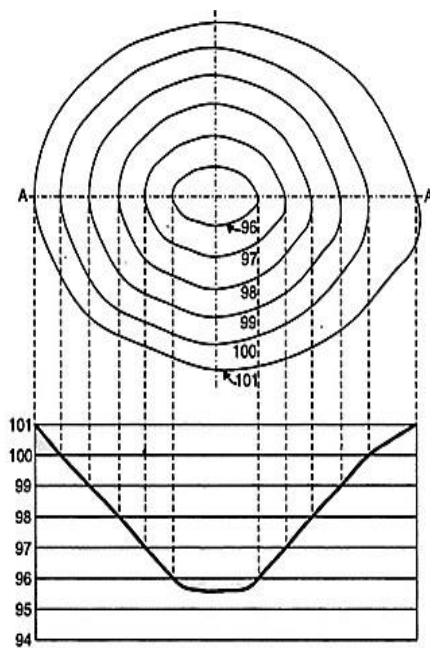

Fig: 3.1

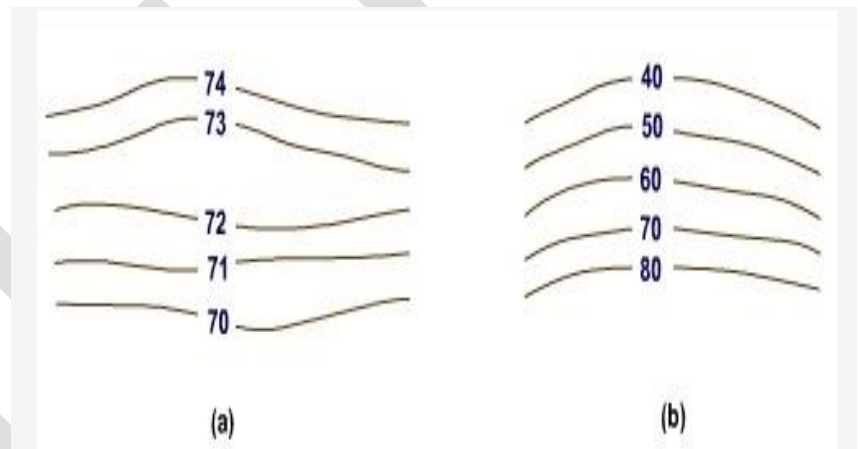

Fig: 3.1(a)

Fid 3.1(b)

The choice of suitable contour interval in a map depends upon four principal considerations. These are:

Nature of Terrain

The contour interval depends upon the nature of the terrain. For flat ground, a small contour interval is chosen whereas for undulating and broken ground, greater contour interval is adopted

Contour Interval (CI) for different types of Survey

Scale of the Map

Sl. No	Purpose of survey	Scale	CI (m)
1	Building site	1/1000 or less	0.2 to 0.5
2	Town planning, reservoir etc.	1/5,000 to 1/10,000	0.5 to 2
3	Location Survey, earthwork, etc.	1/10,000 to 1/20,000	1 to 3

The contour interval normally varies inversely to the scale of the map i.e., if the scale of map is large, the contour interval is considered to be small and vice versa

CI for different scales and types of Ground

Sl.NO	Map Scale	Type of Terrain	CI(m)
1	Large (1:1000 or less)	Flat	0.2 to 0.5
		Rolling	0.5 to 1
		Hilly	1 to 2
2	Intermediate (1:1000 to 1:10,000)	Flat	0.5 to 1.5
		Rolling	1.5 to 2
		Hilly	2 to 3
3	Small (1:10,000 or more)	Flat	1 to 3
		Rolling	3 to 5
		Hilly	5 to 10



Accuracy

Accuracy need of surveying work also decide the contour interval. Surveying for detailed design work or for earthwork calculations demands high accuracy and thus a small contour interval is used. But in case of location surveys where the desired accuracy is less, higher contour interval should be used.

Time and Cost

If the contour interval is small, greater time and funds will be required in the field survey, in reduction and in plotting the map. If the time and funds available are limited, the contour interval may be kept large.

Horizontal Equivalent

The horizontal distance between two points on two consecutive contour lines for a given slope is known as horizontal equivalent. For example, in Figure 5.17 (b) having contour interval 10m, the horizontal equivalent in a slope of 1 in 5 would be 50 m. Thus, horizontal equivalent depends upon the slope of the ground and required grade for construction of a road, canal and contour interval.

Characteristics of Contour

The principal characteristics of contour lines which help in plotting or reading a contour map areas follows:

1. The variation of vertical distance between any two contour lines is assumed to be uniform.
2. The horizontal distance between any two contour lines indicates the amount of slope and varies inversely on the amount of slope. Thus, contours are spaced equally for uniform slope; closely for steep slope contours and widely for moderate slope ([Figure 3.2](#)).
3. The steepest slope of terrain at any point on a contour is represented along the normal of the contour at that point ([Figure 3.3](#)). They are perpendicular to ridge and valley lines where they cross such lines.
4. Contours do not pass through permanent structures such as buildings ([Figure 3.4](#))

5. Contours of different elevations cannot cross each other (caves and overhanging cliffs are the exceptions). ([Figure 3.5](#))
6. Contours of different elevations cannot unite to form one contour (vertical cliff is an exception). ([Figure 3.6](#))
7. Contour lines cannot begin or end on the plan.
8. A contour line must close itself but need not be necessarily within the limits of the map.
9. A closed contour line on a map represents either depression or hill ([Figure 3.7 \(a\)](#)). A set of ring contours with higher values inside, depicts a hill whereas the lower value inside, depicts a depression (without an outlet) [Figure 3.7 \(b\)](#).
10. Contours deflect uphill at valley lines and downhill at ridge lines. Contour lines in U- shape cross a ridge and in V- shape cross a valley at right angles. The concavity in contour lines is towards higher ground in the case of ridge and towards lower ground in the case of valley ([Figure 3.8](#)).
11. Contours do not have sharp turnings.

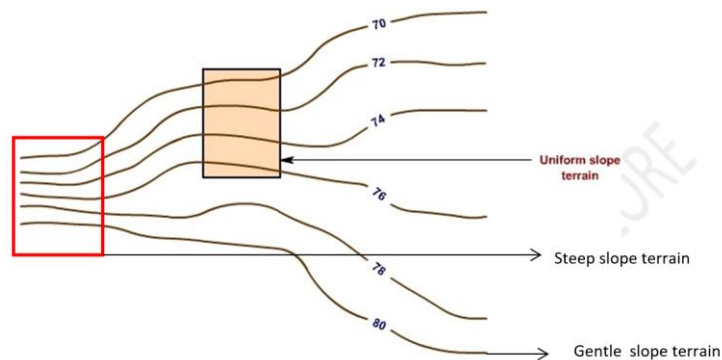

Fig 3.2 Contour of terrain having different type of slope

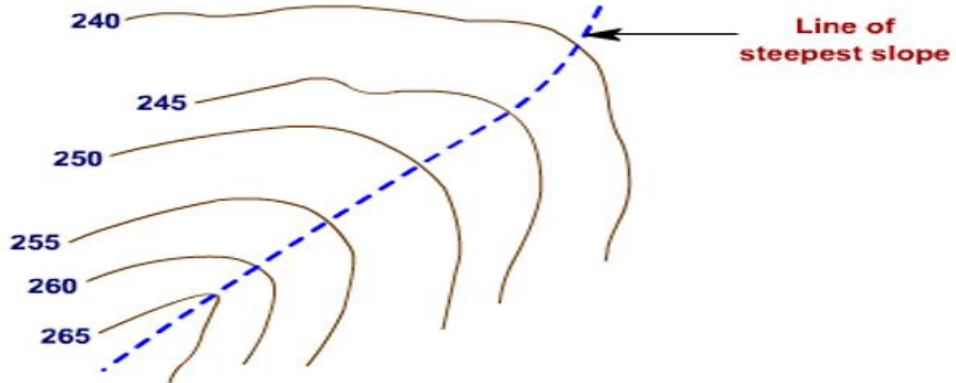

Fig 3.3 Steepest slope of terrain indicated at contour lines

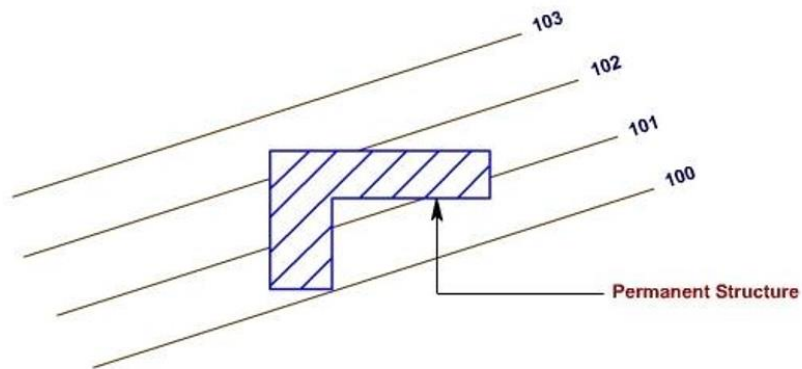

Fig 3.4 Contour across permanent structure

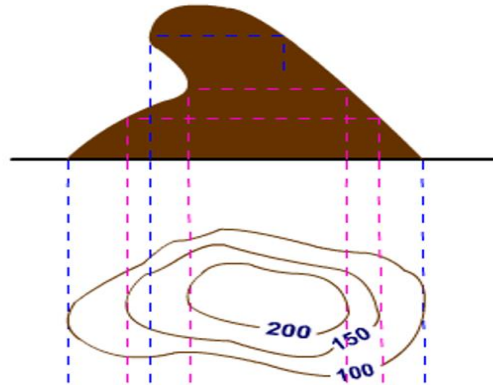

Fig 3.5 Overhanging cliff and its contour

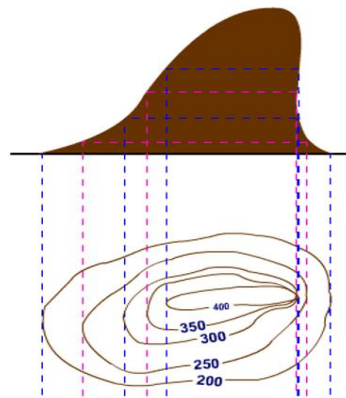

Fig 3.6 Vertical cliff and its contour

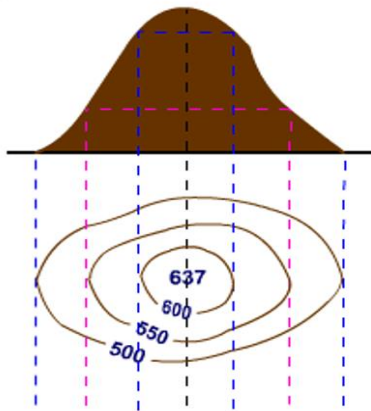

Fig 3.7 a Hill and its contour

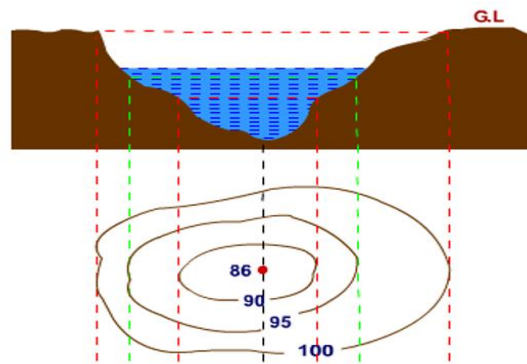

Fig 3.7 b Pond and its contour

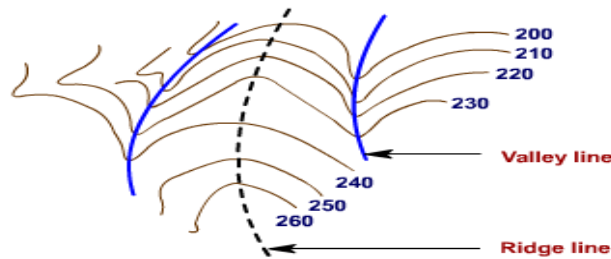

Figure 3.8 Valley and Ridge line

Method of contouring

The method of establishing / plotting contours in a plan or map is known as contouring. It requires planimetric position of the points and drawing of contours from elevations of the plotted points. Contouring involves providing of vertical control for location of points on the contours and horizontal control for planimetric plotting of points. Thus, contouring depends upon the instruments used (to determine the horizontal as well as vertical position of points). In general, the field methods of contouring may be divided into two classes:

- Direct Method
- Indirect Method

Direct Method

In the direct method, the contour to be plotted is actually traced on the ground. Points which happen to fall on a desired contour are only surveyed, plotted and finally joined to obtain the particular contour. This method is slow and tedious and thus used for large scale maps, small contour interval and at high degree of precision. Direct method of contouring can be employed using Level and Staff as follows:

Vertical control: The point on the contours are traced either with the help of a level and staff or with the help of a hand level. In this method, a benchmark is required in the project area. The level is set up on any commanding position and back sight is taken on the bench mark. Let the back sight reading on the bench mark be 1.485 m. If the reduced level of the bench mark is 100 m, the height of instrument would be $100 + 1.485 = 101.485$ m. To locate the contour of 100.5 m value, the staff man is directed to occupy the position on the ground where the staff reading is

$101.485 - 100.500 = 0.985$ m. Mark all such positions on the ground where the staff reading would be 0.985 m by inserting pegs. Similarly locate the points where the staff reading would be

$101.485 - 101 = 0.485$ m for 101m contour. The contour of 101.5 m cannot be set from this setting of the instrument because the height of instrument for this setting of the instrument is only 101.485 m. Therefore, locating contours of higher value, the instrument has to be shifted to some other suitable position. Establish a forward station on a firm ground and take fore sight on it. This point acts as a point of known elevation, for shifting the position of the instrument to another position, from where the work proceeds in the similar manner till the entire area is contoured.

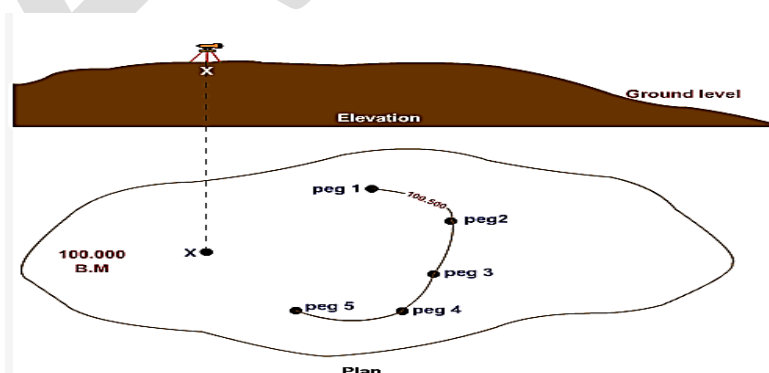



If a hand level is used, slightly different procedure is adopted in locating the points on the contour. A ranging pole having marks at every decimeter interval may be used in conjunction with any type of hand level, preferably an Abney Clinometer.

To start with, a point is located on one of the contours, by levelling from a B.M. The starting point must be located on the contour which is a mean of those to be commanded from that position. The surveyor then holds the hand level at that point and directs the rod man till the point on the rod corresponding to the height of the instrument above the ground is bisected. To do this conveniently, the level should be held against a pole at some convenient height, say, 1.50 meters. If the instrument (i.e. the hand level) is at 100 m contour, the reading of the rod to be bisected at each point of 100.5 m, with the same instrument position, will be $(1.50 - 0.5) = 1.0$ meter. The work can thus be continued. The staff man should be instructed to insert a lath or twig at the point thus located. The twig must be split to receive a piece of paper on which R.L. of the contour should be written.

Horizontal Control

After having located the points on various contours, they are to be surveyed with a suitable control system. The system to be adopted depends mainly on the type and extent areas. For small area, chain surveying may be used and the points may be located by offsets from the survey lines. In a work of larger nature, a traverse may be used. The traverse may be a theodolite or a compass or a plane table traverse.

In the direct method, two survey parties generally work simultaneously - one locating on the contours and the other surveying those points. However, if the work is of small nature, the points may be located first and then surveyed by the same party.

Indirect Methods

In this method, points are located in the field, generally as corners of well-shaped geometrical figures



such as squares, rectangles, and spot levels are determined. Elevations of desired contours are interpolated in between spot levels and contour lines are drawn by joining points of equal elevation.

Indirect methods are less expensive, less time consuming and less tedious as compared to the direct method. These methods are commonly employed in small scale surveys of large areas or during mapping of irregular surface or steep slope. There are two different ways usually employed for indirect method of contouring:

- Grid method
- By cross section
- Radial line method

a) Grid Method

In this method, the area to be surveyed is divided into a grid or series of squares (Figure 3.9). The grid size may vary from 5 m x 5 m to 25 m x 25 m depending upon the nature of the terrain, the contour interval required and the scale of the map desired. Also, the grids may not be of the same size throughout but may vary depending upon the requirement and field conditions. The grid corners are marked on the ground and spot levels of these corners are determined by leveling. The grid is plotted to the scale of the map and the spot levels of the grid corners are entered. The contours of desired values are then located by interpolation. Special care should be taken to give the spot levels to the salient features of the ground such as hilltops, deepest points of the depressions, and their measurements from respective corners of the grids, for correct depiction of the features. The method is used for large scale mapping and at average precision.

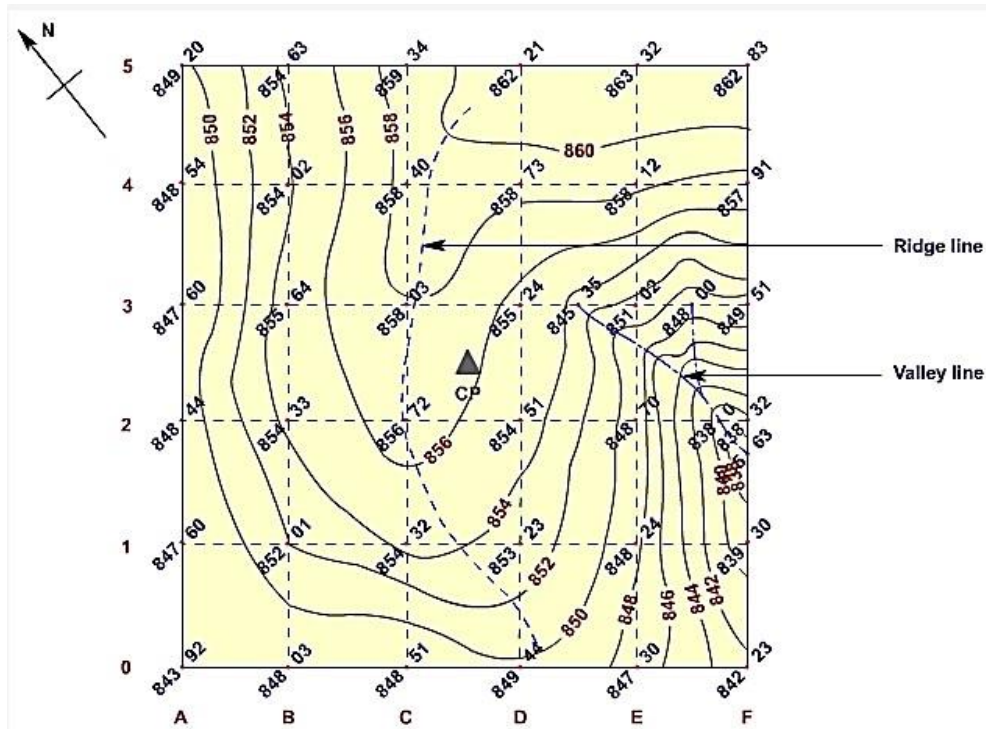

Fig 3.9 Contouring by grid method

b) By Cross-sections

In this method, cross-sections are run transverse to the center line of a road, railway or canal etc. The method is most suitable for railway route surveys. The spacing of the cross-section depends upon the character of the terrain, the contour interval and the purpose of the survey. The cross-sections should be more closely spaced where the contours curve abruptly, as in ravines or on spurs. The cross-section and the points can then be plotted and the elevation of each point is marked. The contour lines are interpolated on the assumption that there is uniform slope between two points on two adjacent contours. Thus, in Fig. 3.10, the points marked with dots are the points surveyed in the field while the points marked with x on the first cross-section are the points interpolated on contours.

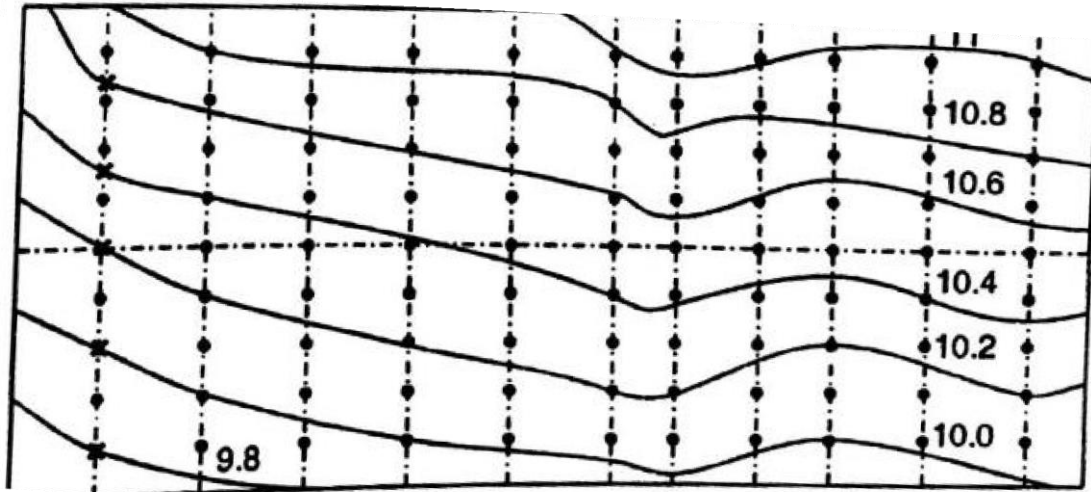

Fig 3.10 Method of cross section

c) Radial Method

In this method, a number of radial lines are set out at known angular interval at each station and points are marked at the ground at convenient distance apart on the rays that are set. Spot levels of these points are determined by leveling. The points are plotted to the scale of the map and spot levels are entered. The contours of desired values are then located by interpolation. This method is convenient in hilly terrain with level stations chosen at high points to command a large area from each. Horizontal control may be obtained by taping (Figure 3.11).

The tacheometric method may be used with advantages for radial contours. tacheometer is a theodolite fitted with stadia diaphragm so that staff readings against all the three hairs may be taken. The staff intercept s is then obtained by taking the difference between the readings against the top and bottom wires. The line of sight can make any inclination with the horizontal, thus increasing the range of instrument observations. The horizontal distances need not be measured. since the tacheometer provides both horizontal and vertical control.

The tacheometer may be set on a point from which greater control can be obtained. Radial lines can then be set making different angles with either the magnetic meridian or with the first radial line (Fig. 3.11). On each radial line, readings may be taken on levelling staff kept at different points. The point must be so chosen that approximate vertical difference in elevation between two consecutive points is less than the contour interval. Thus, on the same radial line, the horizontal equivalent will be smaller for those two points the vertical difference in elevation of which is greater and vice versa.

To survey an area connected by series of hillocks, a tacheometric traverse may be run, the tacheometric traverse stations being chosen at some commanding position. At each traverse station, several radial lines may be run in various directions as required, the horizontal control being entirely obtained by the tacheometer. The traverse, the lines and the points can then be plotted. The elevation of each point is calculated by tacheometric formulae and entered, and the contours can be interpolated as usual.

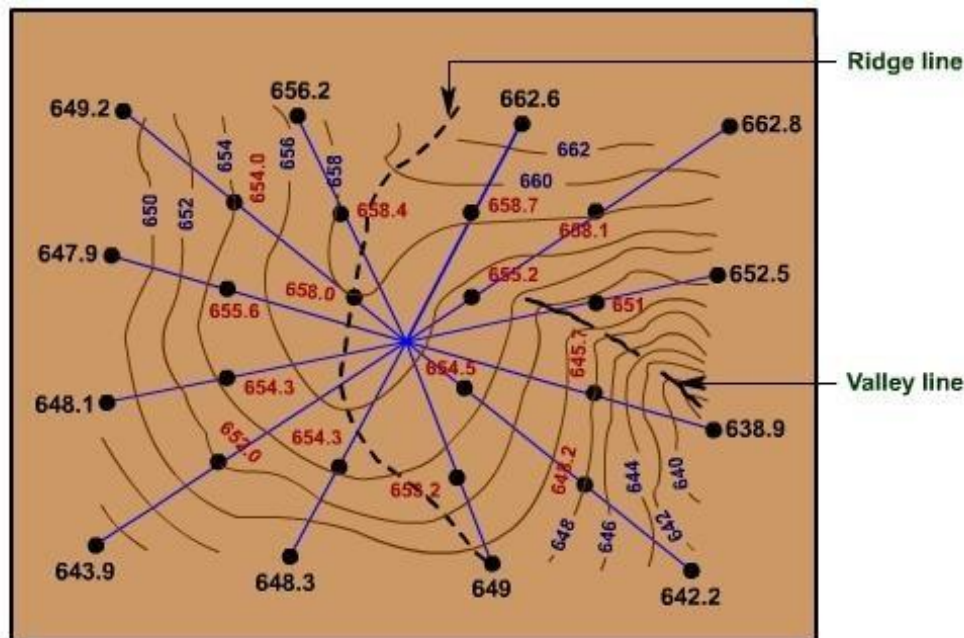

Fig 3.11 Contouring by radial line method

A Comparison between Direct and Indirect Methods of Contouring

	Direct Method	Indirect Method
1	Very accurate but slow and tedious	Not very accurate but quicker and less tedious.
2	Expensive	Reasonable cost
3	Appropriate for small projects requiring high accuracy, e.g., layout of building, factory, structural foundations, etc.	Suitable for large projects requiring moderate to low accuracy, e.g., layout of highway, railway, canal, etc.
4	More suitable for low undulating terrain.	Suitable for hilly terrain.
5	Calculations need to be carried out in the field	Calculation in the field is not mandatory.
6	After contouring, calculation cannot be checked.	Calculations can be checked as and when needed

Interpolation of contours

Interpolation of the contours is the process of spacing the contours proportionately between plotted ground points. The chief methods of interpolation are

1. By estimation
2. By arithmetic calculations
3. By graphical method

By Estimation:

This method is extremely rough and is used for small scale work only. The positions of contours points between the guide points are located by estimation.



By Arithmetic calculations :

This method is accurate but time consuming. The positions of contour points between the guide points are located by arithmetic calculation.

For example, let A and B are two points of RL 52.6 and 55.8 at 16m apart.

Difference of level between A and B is $55.8 - 52.6 = 3.20\text{m}$

(For locating 53.0m contour line) Difference of level between A and 53.0m contour = $53.0 - 52.6 = 0.4\text{m}$

Distance of 53.0 m contour from A = $0.4 \times 16/3.20 = 2.0\text{m}$

Similarly locating 54.0m contour, Distance of 54.0m contour from point A = $(54.0 - 52.6) \times 16/3.2 = 7.0\text{m}$

By Graphical method:

When high accuracy is required and many interpolations are to be made, this method of plotting contours are most rapid and convenient. On tracing paper, parallel lines are drawn at some fixed interval, say 0.5m. Every tenth line is made thicker. Let A and B be two points of elevation at 50.5m and 64.50m respectively. The tracing paper is placed with point A on the line 50.5m and is turned till the point B is on line 64.5m. The intersections of line AB and the lines of required elevation point will give the position of point on the respective contours.

The second method is illustrated in Fig. 3.12. A line XY of any convenient length is taken on a tracing cloth and divided into several parts, each representing any interval, say 0.2 m. On a line perpendicular to XY at its mid-point, a pole O is chosen and radial lines are drawn joining the pole O and the division on the line XY. Let the bottom radial line represent an elevation of 97.0. If required each fifth radial line representing one meters interval may be made dark. Let it be required to interpolate contours of 98, 99, 100 and 101 metres elevations between two points A and B having elevations of 97.6 and 101.8 metres. Arrange the tracing cloth on the line AB in such a way that the point A and B lie simultaneously on radial line representing 97.6 and 101.8 meters respectively. The 99, 100 and 101 metres intersect AB may then be picked through.

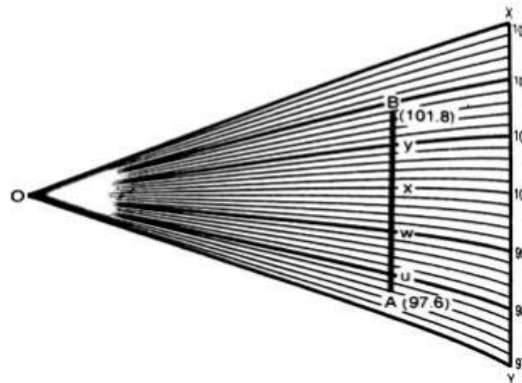

Fig 3.12

Contour Drawing

After having interpolated the contour points between a network of guide points, smooth curves of the contour lines may be drawn through their corresponding contour points. While drawing the contour lines the fundamental properties of contour lines must be borne in mind. The contour lines should be inked in either black or brown. If the contour plan also shows the features like roads, etc., it is preferable to use brown ink for the contour so as to distinguish it clearly from rest of the features. The value of the contours should be written in a systematic and uniform manner.



CONTOUR GRADIENT

Contour gradient is a line lying throughout on the surface of the ground and preserving a constant inclination to the horizontal. If the inclination of such a line is given, its direction from a point may be easily located either on the map or on the ground. To locate the contour gradient in the field, a clinometer, a theodolite, or a level may be used. Let it be required to trace a contour gradient of inclination 1 in 100, starting from a point A, with the help of a clinometer. The clinometer is held at A and its line of sight is clamped at an inclination of 1 in 100. Another person having a target at a height equal to the height of the observer's eye is directed by the observer to move up or down the slope till the target is bisected by the line of sight. The point is then pegged on the ground. The clinometer is then moved to the point so obtained and another point is obtained in a similar manner. The line between any two pegs will be parallel to the line of sight.

If a level is used to locate the Contour gradient, it is not necessary to set the level on the contour gradient. The level is set at a commanding position and reading on the staff kept at the first point is taken. For numerical example, let the reading be 1.21 metres. The reading on another peg B (say) distant 20 metres from A, with a contour gradient of 1 in 100, will be $1.21 + 0.20 = 1.41$ metres. To locate the point B. the staff man holds the 20 metres end of chain or tape (with zero metre end at A) and moves till the reading on the staff is 1.41 metres. Thus, from one single instrument station several located.

Uses /Applications of Contour Maps

Contour maps are extremely useful for various engineering works:

1. A civil engineer studies the contours and finds out the nature of the ground to identify. Suitable site for the project works to be taken up.
2. By drawing the section in the plan, it is possible to find out profile of the ground along that line. It helps in finding out depth of cutting and filling, if formation level of road/railway is decided.
3. Intervisibility of any two points can be found by drawing profile of the ground along that line.
4. The routes of the railway, road, canal or sewer lines can be decided so as to minimize and balance earthworks.



5. Catchment area and hence quantity of water flow at any point of nalla or river can be found. This study is very important in locating bunds, dams and also to find out flood levels.
6. From the contours, it is possible to determine the capacity of a reservoir.

PURPOSE OF CONTOURING

- Contour survey is carried out at the starting of any engineering project such as a road, a railway, a canal, a dam, a building etc.
- For preparing contour maps to select the most economical or suitable site.
- To locate the alignment of a canal so that it should follow a ridge line.
- To mark the alignment of roads and railways so that the quantity of earthwork both in cutting and filling should be minimum.
- For getting information about the ground whether it is flat, mountainous.
- To find the capacity of a reservoir and volume of earthwork especially in a mountainous region.
- To trace out the given grade of a particular route.
- To locate the physical features of the ground such as a pond, hill, steep or small slopes.

Contouring using level: In this method, levels are taken at some selected points and their levels are reduced. Thus, in this method horizontal control is established first and then the levels of those points found. After locating the points on the plan, reduced levels are marked and contour lines are interpolated between the selected points.

Plotting of contours in CAD.

1. Import Data from excel : Select 5 Columns in excel respectively Serial Number, X value, Y value, Z value and Remark. In SW_DTM, Click Points>Import Points From EXCEL

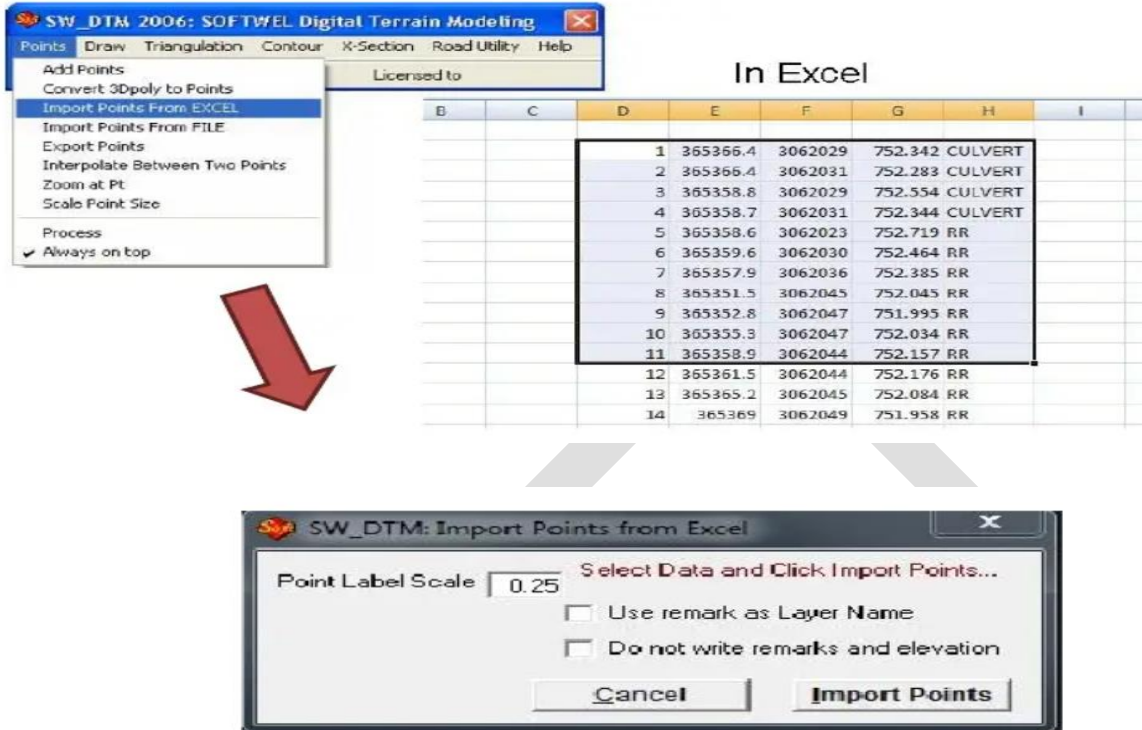

The points will be plotted in Auto CADD

2. Process:

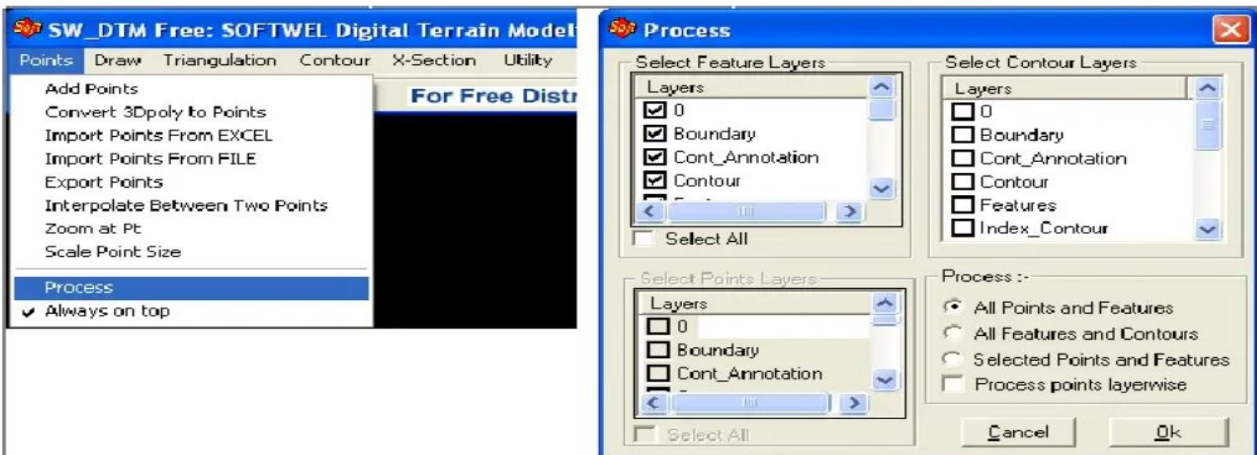

Select feature layers if required.

3. Triangulate:

In SW_DTM, Select Triangulate, then click on Remove Duplicates, Raw Triangulation and Boundary Adjustment.

In Case Error appear on Raw triangulate, triang1.exe is available at installed folder (C:\Program Files \Softwel\SW_DTM_Free), run it.

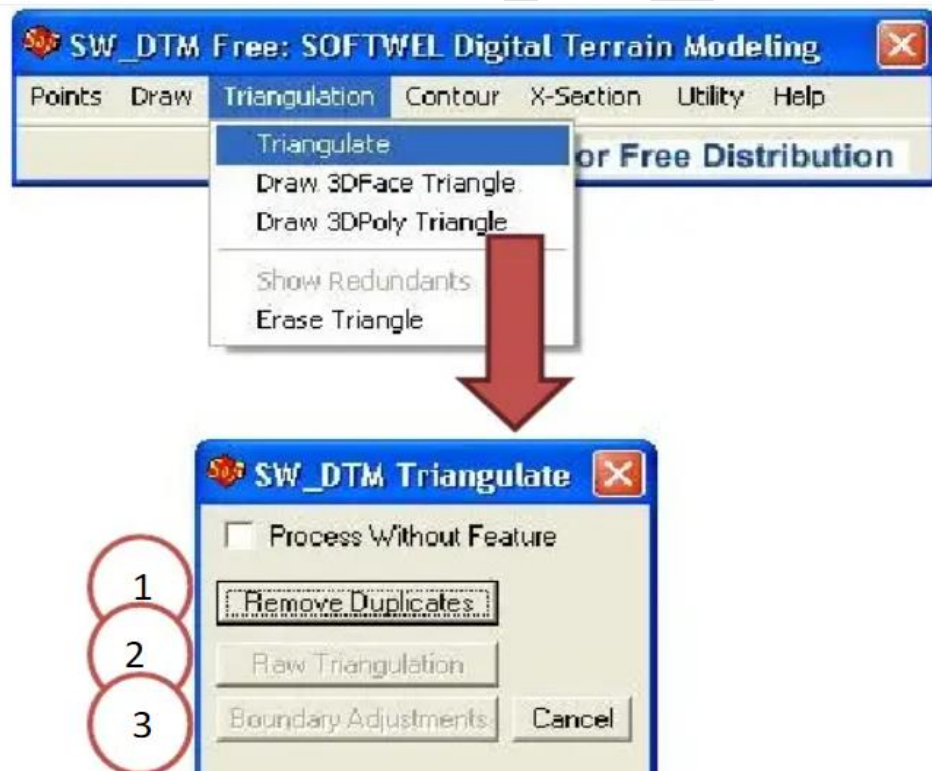

4. Draw contour:

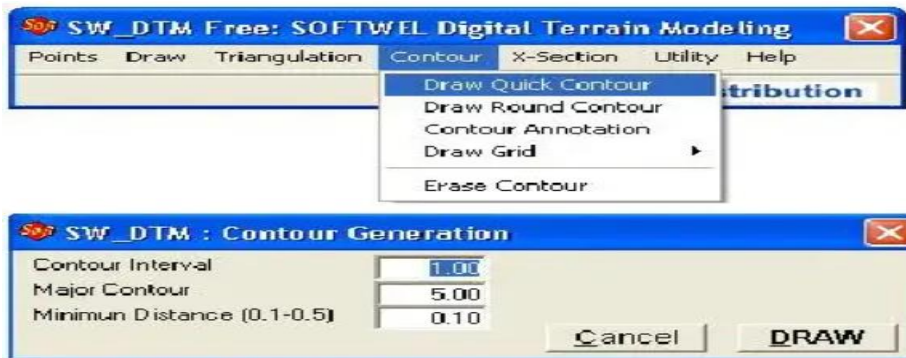

Contour in Autocad:



Boundary line stopped interpolation between these 2 points, as a result no contour in between these 2 points.



IMPORTANT QUESTIONS:

1. Describe Interpolation of Contours
2. Enumerate the characteristic of contour with neat sketch
3. Define the contour. List the use of contour maps.
4. Explain the different methods of contouring

AJIET