

**Course Outcomes**

- CO 1:** Identify key challenges in managing information and analyze different storage networking technologies and virtualization
- CO 2:** Explain components and the implementation of NAS
- CO 3:** Describe CAS architecture and types of archives and forms of virtualization
- CO 4:** Illustrate the storage infrastructure and management activities

**Institution Vision**

To produce top-quality engineers who are groomed for attaining excellence in their profession and competitive enough to help in the growth of nation and global society.

**Institution Mission**

- M1:** To offer affordable high-quality graduate program in engineering with value education and make the students socially responsible.
- M2:** To support and enhance the institutional environment to attain research excellence in both faculty and students and to inspire them to push the boundaries of knowledge base.
- M3:** To identify the common areas of interest amongst the individuals for the effective industry- institute partnership in a sustainable way by systematically working together.
- M4:** To promote the entrepreneurial attitude and inculcate innovative ideas among the engineering professionals.

**Department Vision**

To be a center of excellence in Information Science & Engineering education, research and training to meet the growing needs of the industry and society.

**Department Mission**

- M1:** To impart theoretical and practical knowledge through the concepts and technologies in Information Science and Engineering
- M2:** To foster research, collaboration and higher education with premier institutions and industries.
- M3:** Promote innovation and entrepreneurship to fulfill the needs of the society and industry

**Program Educational Objectives**

- PEO1:** Analyse, design and implement solutions to the real-world problems in the field of Information Science and Engineering with multidisciplinary setup
- PEO2:** Keep abreast with the technology, innovation and pursue higher education with high standards of social and professional ethics
- PEO3:** Develop professional and entrepreneurship skills to work effectively as an individual and in a team to meet the ever-changing goals of the organization

**Program Outcomes**

- PO1: Engineering knowledge:** Apply the knowledge of mathematics, science, engineering fundamentals and an engineering specialization to the solution of complex engineering problems.

- PO2: Problem Analysis:** Identify, formulate, review research literature, and analyse complex engineering problems reaching substantiated conclusions using first principles of mathematics, natural science and engineering sciences.
- PO3: Design/development of solutions:** Design solutions for complex engineering problems and design system components or processes that meet the specified needs with appropriate consideration for the public health and safety, and the cultural, societal and environmental considerations.
- PO4: Conduct investigations of complex problems:** Use research based knowledge and research methods including design of experiments, analysis and interpretation of data, and synthesis of the information to provide valid conclusions.
- PO5: Modern tool usage:** Create, select and apply appropriate techniques, resources and modern engineering and IT tools including prediction and modelling to complex engineering activities with an understanding of the limitations
- PO6: The engineer and society:** Apply reasoning informed by the contextual knowledge to assess societal, health, safety, legal and cultural issues and the consequent responsibilities relevant to the professional engineering practice
- PO7: Environment sustainability:** Understand the impact of the professional engineering solutions in the societal and environmental contexts, and demonstrate the knowledge of, and need for sustainable development.
- PO8: Ethics:** Apply ethical principles and commit to professional ethics and responsibilities and norms of the engineering practice.
- PO9: Individual and team work:** Function effectively as an individual and as a member or leader in diverse teams, and in multidisciplinary settings.
- PO10: Communication:** Communicate effectively on complex engineering activities with the engineering community and with society at large, such as, being able to comprehend and write effective reports and design documentation, make effective presentations, and give and receive clear instructions
- PO11: Project management and finance:** Demonstrate knowledge and understanding of the engineering and management principles and apply these to ones own work, as a member and leader in a team, to manage projects and in multidisciplinary environments.
- PO12: Lifelong learning:** Recognize the need for, and have the preparation and ability to engage in independent and lifelong learning in the broader context of technological change.

#### **Program Specific Outcome**

- PSO1:** Design, implement and maintain the information systems that fulfill the current needs of the industry and society
- PSO2:** Apply computational theory, storage and networking concepts to solve the day to day problems of the world

---

## Introduction to Business Continuity

In today's world, continuous access to information is a must for the smooth functioning of business operations. The cost of unavailability of information is greater than ever, and outages in key industries cost millions of dollars per hour. There are many threats to information availability, such as natural disasters, unplanned occurrences, and planned occurrences that could result in the inaccessibility of information. Therefore it is critical for businesses to define an appropriate strategy that can help them overcome these crises.

Business continuity is an important process to define and implement these strategies. *Business continuity* (BC) is an integrated and enterprise-wide process that includes all activities (internal and external to IT) that a business must perform to mitigate the impact of planned and unplanned downtime. BC entails preparing for, responding to, and recovering from a system outage that adversely affects business operations. It involves proactive measures, such as business impact analysis, risk assessments, BC technology solutions deployment (backup and replication), and reactive measures, such as disaster recovery and restart, to be invoked in the event of a failure. The goal of a BC solution is to ensure the "information availability" required to conduct vital business operations.

In a virtualized environment, BC technology solutions need to protect both physical and virtualized resources. Virtualization considerably simplifies the implementation of BC strategy and solutions.

### Information Availability

*Information availability* (IA) refers to the ability of an IT infrastructure to function according to business expectations during its specified time of operation. IA ensures that people (employees, customers, suppliers, and partners) can access information whenever they need it. IA can be defined in terms of accessibility, reliability, and timeliness of information.

**Accessibility:** Information should be accessible at the right place, to the right user.

**Reliability:** Information should be reliable and correct in all aspects. It is "the same" as what was stored, and there is no alteration or corruption to the information.

**Timeliness:** Defines the exact moment or the time window (a particular time of the day, week, month, and year as specified) during which information must be accessible. For example, if online access to an application is required between 8:00 a.m. and 10:00 p.m. each day, any disruptions to data availability outside of this time slot are not considered to affect timeliness.

### Causes of Information Unavailability

Various planned and unplanned incidents result in information unavailability. *Planned outages* include installation/integration/maintenance of new hardware, software upgrades or patches, taking backups, application and data restores, facility operations (renovation and construction), and refresh/migration of the testing to the production environment. *Unplanned outages* include failure caused by human errors, database corruption, and failure of physical and virtual components.

Another type of incident that may cause data unavailability is natural or manmade disasters, such as flood, fire, earthquake, and contamination. As illustrated in Figure 9-1, the majority of outages are planned. Planned outages are expected and scheduled but still cause data to be unavailable. Statistically, the cause of information unavailability due to unforeseen disasters is less than 1 percent.

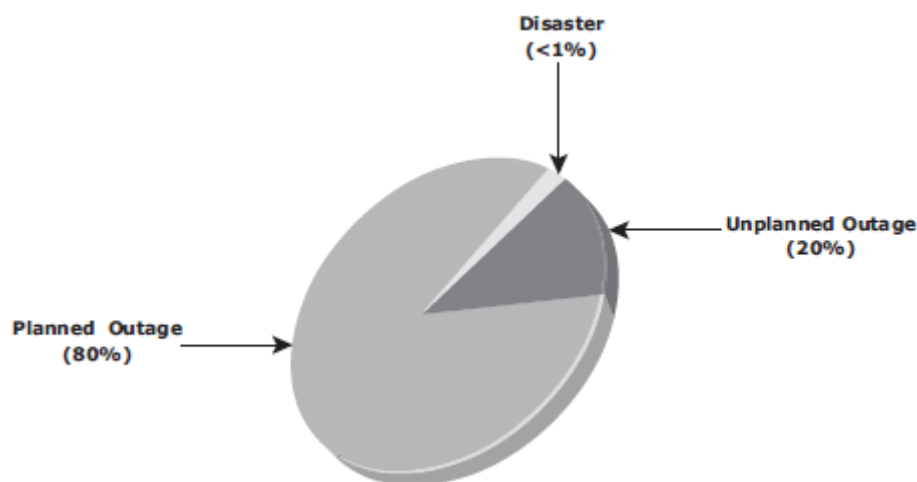

**Figure 9-1:** Disruptors of information availability

### Consequences of Downtime

Information unavailability or downtime results in loss of productivity, loss of revenue, poor financial performance, and damage to reputation. Loss of productivity includes reduced output per unit of labor, equipment, and capital. Loss of revenue includes direct loss, compensatory payments, future revenue loss, billing loss, and investment loss. Poor financial performance affects revenue recognition, cash flow, discounts, payment guarantees, credit rating, and stock price. Damages to reputations may result in a loss of confidence or credibility with customers, suppliers, financial markets, banks, and business partners. Other possible consequences of downtime include the cost of additional equipment rental, overtime, and extra shipping.

The business impact of downtime is the sum of all losses sustained as a result of a given disruption. An important metric, *average cost of downtime per hour*, provides a key estimate in determining the appropriate BC solutions. It is calculated as follows:

$$\text{Average cost of downtime per hour} = \text{average productivity loss per hour} + \text{average revenue loss per hour}$$

Where:

$$\text{Productivity loss per hour} = (\text{total salaries and benefits of all employees per week}) / (\text{average number of working hours per week})$$

$$\text{Average revenue loss per hour} = (\text{total revenue of an organization per week}) / (\text{average number of hours per week that an organization is open for business})$$

The average downtime cost per hour may also include estimates of projected revenue loss due to other consequences, such as damaged reputations, and the additional cost of repairing the system.

### Measuring Information Availability

IA relies on the availability of both physical and virtual components of a data center. Failure of these components might disrupt IA. A failure is the termination of a component's capability to perform a required function. The component's capability can be restored by performing an external corrective action, such as a manual reboot, repair, or replacement of the failed component(s). Repair involves restoring a component to a condition that enables it to perform a required function. Proactive risk analysis, performed as part of the BC planning process, considers the component failure rate and average repair time, which are measured by mean time between failure (MTBF) and mean time to repair (MTTR):

- **Mean Time Between Failure (MTBF):** It is the average time available for a system or component to perform its normal operations between failures. It is the measure of system or component reliability and is usually expressed in hours.
- **Mean Time To Repair (MTTR):** It is the average time required to repair a failed component. While calculating MTTR, it is assumed that the fault responsible for the failure is correctly identified and the required spares and personnel are available. A fault is a physical defect at the component level, which may result in information unavailability. MTTR includes the total time required to do the following activities: Detect the fault, mobilize the maintenance team, diagnose the fault, obtain the spare parts, repair, test, and restore the data. Figure 9-2 illustrates the various information availability metrics that represent system uptime and downtime.

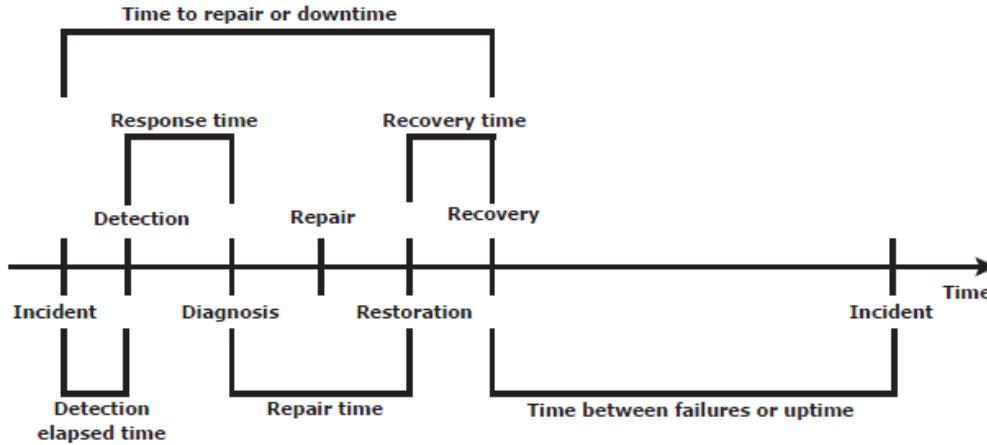

**Figure 9-2:** Information availability metrics

IA is the time period during which a system is in a condition to perform its intended function upon demand. It can be expressed in terms of system uptime and downtime and measured as the amount or percentage of system uptime:

$$IA = \text{system uptime} / (\text{system uptime} + \text{system downtime})$$

Where *system uptime* is the period of time during which the system is in an accessible state; when it is not accessible, it is termed as *system downtime*. In terms of MTBF and MTTR, IA could also be expressed as

$$IA = \text{MTBF} / (\text{MTBF} + \text{MTTR})$$

Uptime per year is based on the exact timeliness requirements of the service. This calculation leads to the number of “9s” representation for availability metrics. Table 9-1 lists the approximate amount of downtime allowed for a service to achieve certain levels of 9s availability. For example, a service that is said to be “fi ve 9s available” is available for 99.999 percent of the scheduled time in a year (24 × 365).

**Table 9-1:** Availability Percentage and Allowable Downtime

UPTIME (%)	DOWNTIME (%)	DOWNTIME PER YEAR	DOWNTIME PER WEEK
98	2	7.3 days	3 hr, 22 minutes
99	1	3.65 days	1 hr, 41 minutes
99.8	0.2	17 hr, 31 minutes	20 minutes, 10 secs
99.9	0.1	8 hr, 45 minutes	10 minutes, 5 secs
99.99	0.01	52.5 minutes	1 minute
99.999	0.001	5.25 minutes	6 secs
99.9999	0.0001	31.5 secs	0.6 secs

## BC Terminology

This section introduces and defines common terms related to BC operations, which are used in the next few chapters to explain advanced concepts:

- **Disaster recovery:** This is the coordinated process of restoring systems, data, and the infrastructure required to support ongoing business operations after a disaster occurs. It is the process of restoring a previous copy of the data and applying logs or other necessary processes to that copy to bring it to a known point of consistency. After all recovery efforts are completed, the data is validated to ensure that it is correct.
- **Disaster restart:** This is the process of restarting business operations with mirrored consistent copies of data and applications.
- **Recovery-Point Objective (RPO):** This is the point in time to which systems and data must be recovered after an outage. It defines the amount of data loss that a business can endure. A large RPO signifies high tolerance to information loss in a business. Based on the RPO, organizations plan for the frequency with which a backup or replica must be made. For example, if the RPO is 6 hours, backups or replicas must be made at least once in 6 hours. Figure 9-3 (a) shows various RPOs and their corresponding ideal recovery strategies. An organization can plan for an appropriate BC technology solution on the basis of the RPO it sets. For example:
  - **RPO of 24 hours:** Backups are created at an offsite tape library every midnight. The corresponding recovery strategy is to restore data from the set of last backup tapes.
  - **RPO of 1 hour:** Shipping database logs to the remote site every hour. The corresponding recovery strategy is to recover the database to the point of the last log shipment.
  - **RPO in the order of minutes:** Mirroring data asynchronously to a remote site
  - **Near zero RPO:** Mirroring data synchronously to a remote site

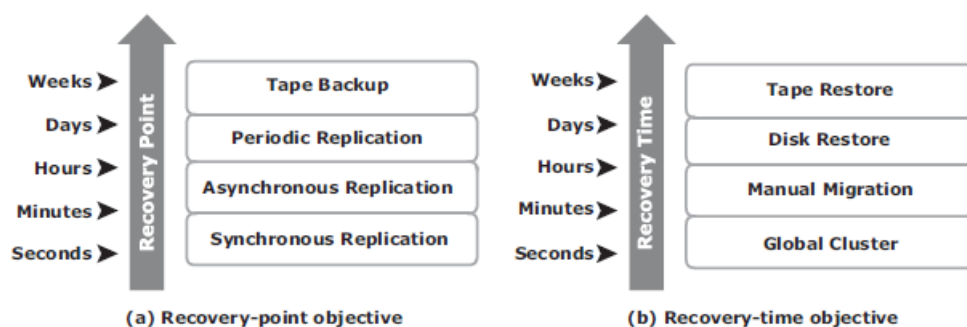

Figure 9-3: Strategies to meet RPO and RTO targets

- **Recovery-Time Objective (RTO):** The time within which systems and applications must be recovered after an outage. It defines the amount of downtime that a business can endure and survive. Businesses can optimize disaster recovery plans after defining the RTO for a given system. For example, if the RTO is 2 hours, it requires disk-based backup because it enables a faster restore than a tape backup. However, for an RTO of 1 week, tape backup will likely meet the requirements. Some examples of RTOs and the recovery strategies to ensure data availability are listed here.
- **RTO of 72 hours:** Restore from tapes available at a cold site.
- **RTO of 12 hours:** Restore from tapes available at a hot site.
- **RTO of few hours:** Use of data vault at a hot site
- **RTO of a few seconds:** Cluster production servers with bidirectional mirroring, enabling the applications to run at both sites simultaneously.
- **Data vault:** A repository at a remote site where data can be periodically or continuously copied (either to tape drives or disks) so that there is always a copy at another site
- **Hot site:** A site where an enterprise's operations can be moved in the event of disaster. It is a site with the required hardware, operating system, application, and network support to perform business operations, where the equipment is available and running at all times.
- **Cold site:** A site where an enterprise's operations can be moved in the event of disaster, with minimum IT infrastructure and environmental facilities in place, but not activated
- **Server Clustering:** A group of servers and other necessary resources coupled to operate as a single system. Clusters can ensure high availability and load balancing. Typically, in failover clusters, one server runs an application and updates the data, and another server is kept as standby to take over completely, as required. In more sophisticated clusters, multiple servers may access data, and typically one server is kept as standby. Server clustering provides load balancing by distributing the application load evenly among multiple servers within the cluster.

### BC Planning Life Cycle

BC planning must follow a disciplined approach like any other planning process. Organizations today dedicate specialized resources to develop and maintain BC plans. From the conceptualization to the realization of the BC plan, a life cycle of activities can be defined for the BC process. The BC planning life cycle includes five stages.

1. Establishing objectives
2. Analyzing
3. Designing and developing
4. Implementing
5. Training, testing, assessing, and maintaining

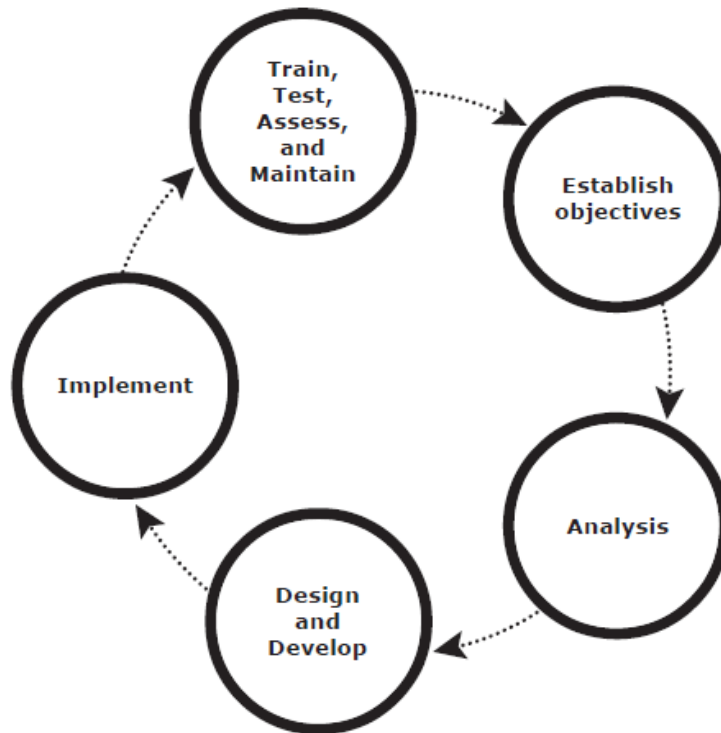

**Figure 9-4:** BC planning life cycle

Several activities are performed at each stage of the BC planning life cycle, including the following key activities:

1. Establish objectives:

- Determine BC requirements.
- Estimate the scope and budget to achieve requirements.
- Select a BC team that includes subject matter experts from all areas of the business, whether internal or external.
- Create BC policies.

2. Analysis:

- Collect information on data profiles, business processes, infrastructure support, dependencies, and frequency of using business infrastructure.
- Conduct a Business Impact Analysis (BIA).
- Identify critical business processes and assign recovery priorities.

- 
- Perform risk analysis for critical functions and create mitigation strategies.
  - Perform cost benefit analysis for available solutions based on the mitigation strategy.
  - Evaluate options.
3. Design and develop:
- Define the team structure and assign individual roles and responsibilities. For example, different teams are formed for activities, such as emergency response, damage assessment, and infrastructure and application recovery.
  - Design data protection strategies and develop infrastructure.
  - Develop contingency solutions.
  - Develop emergency response procedures.
  - Detail recovery and restart procedures.
4. Implement:
- Implement risk management and mitigation procedures that include backup, replication, and management of resources.
  - Prepare the disaster recovery sites that can be utilized if a disaster affects the primary data center.
  - Implement redundancy for every resource in a data center to avoid single points of failure.
5. Train, test, assess, and maintain:
- Train the employees who are responsible for backup and replication of business-critical data on a regular basis or whenever there is a modification in the BC plan.
  - Train employees on emergency response procedures when disasters are declared.
  - Train the recovery team on recovery procedures based on contingency scenarios.
  - Perform damage-assessment processes and review recovery plans.
  - Test the BC plan regularly to evaluate its performance and identify its limitations.
  - Assess the performance reports and identify limitations.
  - Update the BC plans and recovery/restart procedures to reflect regular changes within the data center.

### Failure Analysis

Failure analysis involves analyzing both the physical and virtual infrastructure components to identify systems that are susceptible to a single point of failure and implementing fault-tolerance mechanisms.

### Single Point of Failure

A *single point of failure* refers to the failure of a component that can terminate the availability of the entire system or IT service. Figure 9-5 depicts a system setup in which an application, running on a VM, provides an interface to the client and performs I/O operations. The client is connected to the server through an IP network, and the server is connected to the storage array through an FC connection.

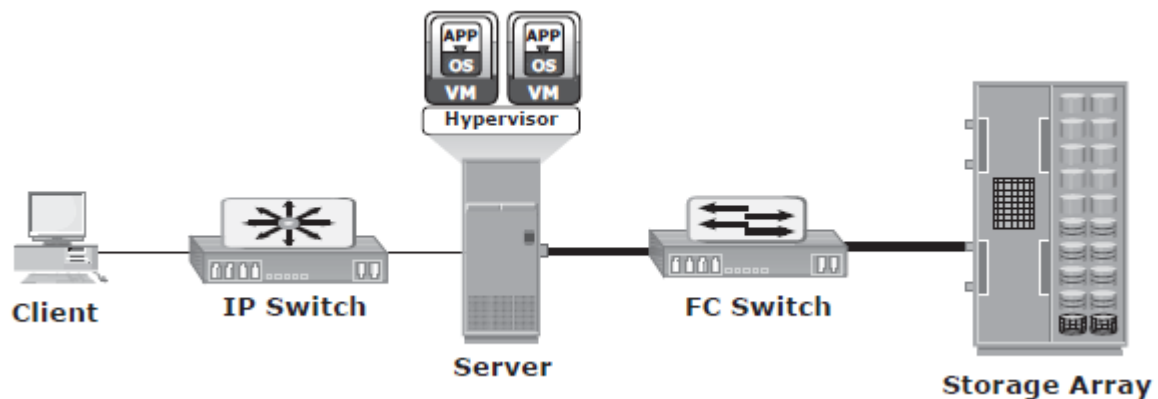

**Figure 9-5:** Single point of failure

In a setup in which each component must function as required to ensure data availability, the failure of a single physical or virtual component causes the unavailability of an application. This failure results in disruption of business operations. For example, failure of a hypervisor can affect all the running VMs and the virtual network, which are hosted on it. In the setup shown in Figure 9-5, several single points of failure can be identified. A VM, a hypervisor, an HBA/NIC on the server, the physical server, the IP network, the FC switch, the storage array ports, or even the storage array could be a potential single point of failure.

### Resolving Single Points of Failure

To mitigate single points of failure, systems are designed with redundancy, such that the system fails only if all the components in the redundancy group fail. This ensures that the failure of a single component does not affect data availability. Data centers follow stringent guidelines to implement fault tolerance for uninterrupted information availability. Careful analysis is performed to eliminate every single point of failure. The example shown in Figure 9-6 represents all enhancements in the infrastructure to mitigate single points of failure:

- Configuration of redundant HBAs at a server to mitigate single HBA failure
- Configuration of NIC teaming at a server allows protection against single physical NIC failure. It allows grouping of two or more physical NICs and treating them as a single

logical device. With NIC teaming, if one of the underlying physical NICs fails or its cable is unplugged, the traffic is redirected to another physical NIC in the team. Thus, NIC teaming eliminates the single point of failure associated with a single physical NIC.

- Configuration of redundant switches to account for a switch failure
- Configuration of multiple storage array ports to mitigate a port failure
- RAID and hot spare configuration to ensure continuous operation in the event of disk failure
- Implementation of a redundant storage array at a remote site to mitigate local site failure
- Implementing server (or compute) clustering, a fault-tolerance mechanism whereby two or more servers in a cluster access the same set of data volumes. Clustered servers exchange a *heartbeat* to inform each other about their health. If one of the servers or hypervisors fails, the other server or hypervisor can take up the workload.
- Implementing a VM Fault Tolerance mechanism ensures BC in the event of a server failure. This technique creates duplicate copies of each VM on another server so that when a VM failure is detected, the duplicate VM can be used for failover. The two VMs are kept in synchronization with each other in order to perform successful failover.

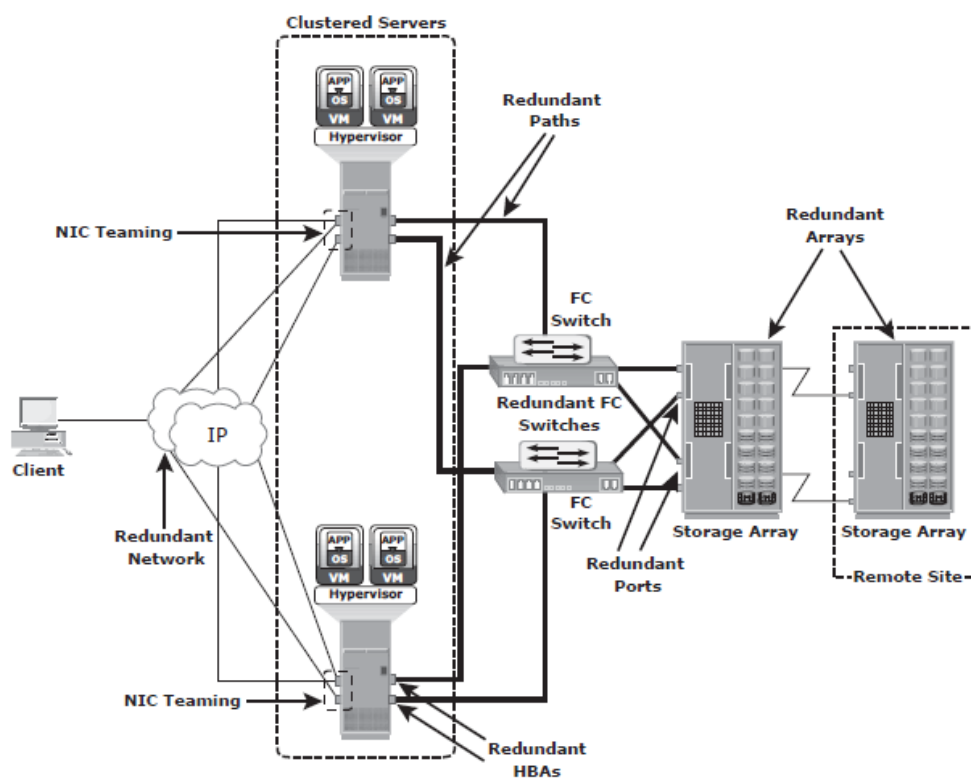

**Figure 9-6:** Resolving single points of failure

### 9.4.3 Multipathing Software

Configuration of multiple paths increases the data availability through path failover. If servers are configured with one I/O path to the data, there will be no access to the data if that path fails. Redundant paths to the data eliminate the possibility of the path becoming a single point of failure. Multiple paths to data also improve I/O performance through load balancing among the paths and maximize server, storage, and data path utilization.

In practice, merely configuring multiple paths does not serve the purpose. Even with multiple paths, if one path fails, I/O does not reroute unless the system recognizes that it has an alternative path. Multipathing software provides the functionality to recognize and utilize alternative I/O paths to data. Multipathing software also manages the load balancing by distributing I/Os to all available, active paths. Multipathing software intelligently manages the paths to a device by sending I/O down the optimal path based on the load balancing and failover policy setting for the device. It also takes into account path usage and availability before deciding the path through which to send the I/O. If a path to the device fails, it automatically reroutes the I/O to an alternative path. In a virtual environment, multipathing is enabled either by using the hypervisor's built-in capability or by running a third-party software module, added to the hypervisor.

### Business Impact Analysis

A *business impact analysis* (BIA) identifies which business units, operations, and processes are essential to the survival of the business. It evaluates the financial, operational, and service impacts of a disruption to essential business processes. Selected functional areas are evaluated to determine resilience of the infrastructure to support information availability. The BIA process leads to a report detailing the incidents and their impact over business functions. The impact may be specified in terms of money or in terms of time. Based on the potential impacts associated with downtime, businesses can prioritize and implement counter measures to mitigate the likelihood of such disruptions. These are detailed in the BC plan. A BIA includes the following set of tasks:

- Determine the business areas.
- For each business area, identify the key business processes critical to its operation.
- Determine the attributes of the business process in terms of applications, databases, and hardware and software requirements.
- Estimate the costs of failure for each business process.

- Calculate the maximum tolerable outage and define RTO and RPO for each business process.
- Establish the minimum resources required for the operation of business processes.
- Determine recovery strategies and the cost for implementing them.
- Optimize the backup and business recovery strategy based on business priorities.
- Analyze the current state of BC readiness and optimize future BC planning.

### BC Technology Solutions

After analyzing the business impact of an outage, designing the appropriate solutions to recover from a failure is the next important activity. One or more copies of the data are maintained using any of the following strategies so that data can be recovered or business operations can be restarted using an alternative copy:

- **Backup:** Data backup is a predominant method of ensuring data availability. The frequency of backup is determined based on RPO, RTO, and the frequency of data changes.
- **Local replication:** Data can be replicated to a separate location within the same storage array. The replica is used independently for other business operations. Replicas can also be used for restoring operations if data corruption occurs.
- **Remote replication:** Data in a storage array can be replicated to another storage array located at a remote site. If the storage array is lost due to a disaster, business operations can be started from the remote storage array.

---

## Backup and Archive

A *backup* is an additional copy of production data, created and retained for the sole purpose of recovering lost or corrupted data. With growing business and regulatory demands for data storage, retention, and availability, organizations are faced with the task of backing up an ever-increasing amount of data. This task becomes more challenging with the growth of information, stagnant IT budgets, and less time for taking backups. Moreover, organizations need a quick restore of backed up data to meet business service-level agreements (SLAs).

Evaluating the various backup methods along with their recovery considerations and retention requirements is an essential step to implement a successful backup and recovery solution.

Organizations generate and maintain large volumes of data, and most of the data is fixed content. This fixed content is rarely accessed after a period of time. Still, this data needs to be retained for several years to meet regulatory compliance. Accumulation of this data on the primary storage increases the overall storage cost to the organization. Further, this increases the amount of data to be backed up, which in turn increases the time required to perform the backup.

*Data archiving* is the process of moving data that is no longer actively used, from primary storage to a low-cost secondary storage. The data is retained in the secondary storage for a long term to meet regulatory requirements. Moving the data from primary storage reduces the amount of data to be backed up. This reduces the time required to back up the data.

### Backup Purpose

Backups are performed to serve three purposes: disaster recovery, operational recovery, and archival. These are covered in the following sections.

### Disaster Recovery

One purpose of backups is to address disaster recovery needs. The backup copies are used for restoring data at an alternate site when the primary site is incapacitated due to a disaster. Based on recovery-point objective (RPO) and recovery-time objective (RTO) requirements, organizations use different data protection strategies for disaster recovery. When tape-based backup is used as a disaster recovery option, the backup tape media is shipped and stored at an offsite location. Later, these tapes can be recalled for restoration at the disaster recovery site. Organizations with stringent RPO and RTO requirements use remote replication technology to replicate data to a disaster recovery site. This allows organizations to bring production systems online in a relatively short period of time if a disaster occurs.

### **Operational Recovery**

Data in the production environment changes with every business transaction and operation. Backups are used to restore data if data loss or logical corruption occurs during routine processing. The majority of restore requests in most organizations fall in this category. For example, it is common for a user to accidentally delete an important e-mail or for a file to become corrupted, which can be restored using backup data.

### **Archival**

Backups are also performed to address archival requirements. Although content addressed storage (CAS) has emerged as the primary solution for archives, traditional backups are still used by small and medium enterprises for long-term preservation of transaction records, e-mail messages, and other business records required for regulatory compliance.

**The period during which a source is available to perform a data backup is called a *backup window*. Performing a backup from the source sometimes requires the production operation to be suspended because the data being backed up is exclusively locked for the use of the backup process.**

### **Backup Considerations**

The amount of data loss and downtime that a business can endure in terms of RPO and RTO are the primary considerations in selecting and implementing a specific backup strategy. RPO refers to the point in time to which data must be recovered, and the point in time from which to restart business operations. This specifies the time interval between two backups. In other words, the RPO determines backup frequency. For example, if an application requires an RPO of 1 day, it would need the data to be backed up at least once every day. Another consideration is the retention period, which defines the duration for which a business needs to retain the backup copies. Some data is retained for years and some only for a few days. For example, data backed up for archival is retained for a longer period than data backed up for operational recovery.

The backup media type or backup target is another consideration that is driven by RTO and impacts the data recovery time. The time-consuming operation of starting and stopping in a tape-based system affects the backup performance, especially while backing up a large number of small files.

Organizations must also consider the granularity of backups, the development of a backup strategy must include a decision about the most appropriate time for performing a backup to minimize any disruption to production operations. The location, size, number of files, and data compression should also be considered because they might affect the backup process. Location is an important consideration for the data to be backed up. Many organizations have dozens of heterogeneous platforms locally and remotely supporting their business. Consider a data warehouse environment that uses the backup data from many sources. The backup process must address these sources for transactional and content integrity. This process must be coordinated with all heterogeneous platforms at all locations on which the data resides.

The file size and number of files also influence the backup process. Backing up large-size files (for example, ten 1 MB files) takes less time, compared to backing up an equal amount of data composed of small-size files (for example, ten thousand 1 KB files).

Data compression and data deduplication are widely used in the backup environment because these technologies save space on the media. Many backup devices have built-in support for hardware-based data compression. Some data, such as application binaries, do not compress well, whereas text data does compress well.

**Backup Granularity**

Backup granularity depends on business needs and the required RTO/RPO. Based on the granularity, backups can be categorized as full, incremental and cumulative (differential). Most organizations use a combination of these three backup types to meet their backup and recovery requirements. Figure 10-1 shows the different backup granularity levels.

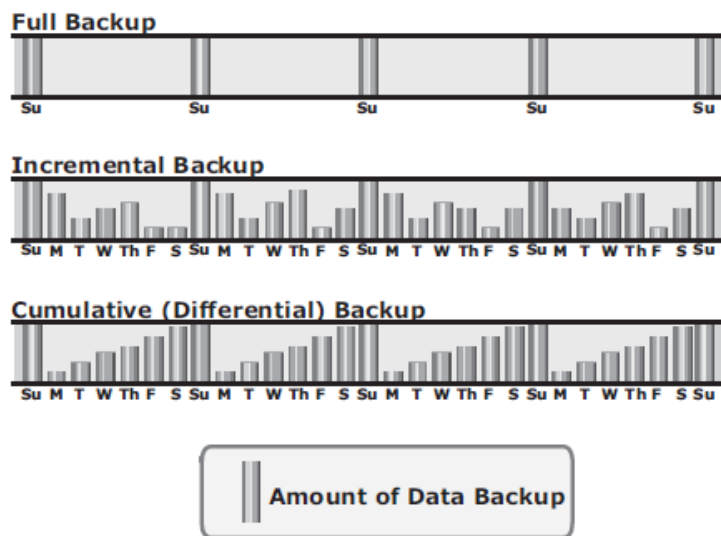
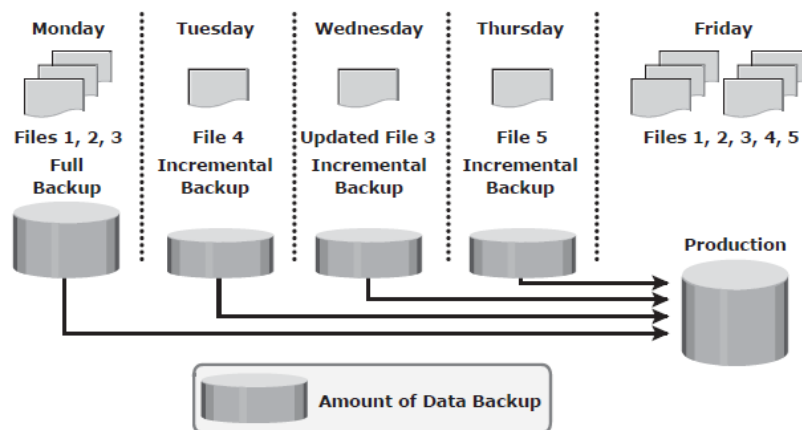

**Figure 10-1:** Backup granularity levels

*Full backup* is a backup of the complete data on the production volumes. A full backup copy is created by copying the data in the production volumes to a backup storage device. It provides a faster recovery but requires more storage space and also takes more time to back up. *Incremental backup* copies the data that has changed since the last full or incremental backup, whichever has occurred more recently. This is much faster than a full backup (because the volume of data backed up is restricted to the changed data only) but takes longer to restore. *Cumulative backup* copies the data that has changed since the last full backup. This method takes longer than an incremental backup but is faster to restore.

**Another way to implement a full backup is to use a *synthetic (or constructed) backup*. This method is used when the production volume resources cannot be exclusively reserved for a backup process for extended periods to perform a full backup. It is usually created from the most recent full backup and all the incremental backups performed after that full backup. This backup is called *synthetic* because the backup is not created directly from production data. A synthetic full backup enables a full backup copy to be created offline without disrupting the I/O operation on the production volume. This also frees up network resources from the backup process, making them available for other production use.**

Restore operations vary with the granularity of the backup. A full backup provides a single repository from which the data can be easily restored. The process of restoration from an incremental backup requires the last full backup and all the incremental backups available until the point of restoration. A restore from a cumulative backup requires the last full backup and the most recent cumulative backup. Figure 10-2 shows an example of restoring data from incremental backup.



**Figure 10-2:** Restoring from an incremental backup

In this example, a full backup is performed on Monday evening. Each day after that, an incremental backup is performed. On Tuesday, a new file (File 4 in the figure) is added, and no other files have changed. Consequently, only File 4 is copied during the incremental backup performed on Tuesday evening. On Wednesday, no new files are added, but File 3 has been modified. Therefore, only the modified File 3 is copied during the incremental backup on Wednesday evening. Similarly, the incremental backup on Thursday copies only File 5. On Friday morning, there is data corruption, which requires data restoration from the backup. The first step toward data restoration is restoring all data from the full backup of Monday evening. The next step is applying the incremental backups of Tuesday, Wednesday, and Thursday. In this manner, data can be successfully recovered to its previous state, as it existed on Thursday evening. Figure 10-3 shows an example of restoring data from cumulative backup.

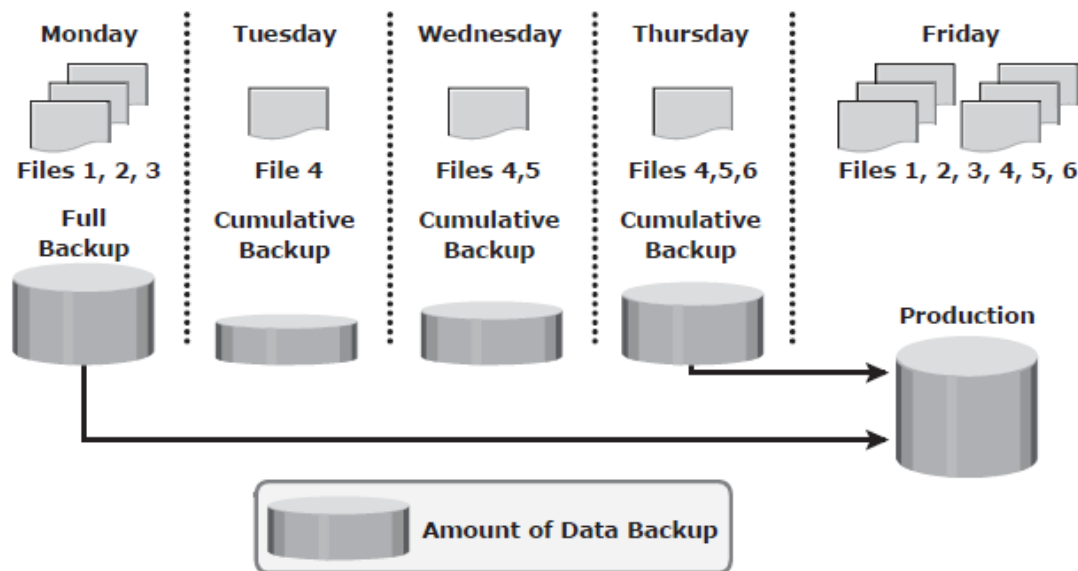

**Figure 10-3:** Restoring a cumulative backup

In this example, a full backup of the business data is taken on Monday evening. Each day after that, a cumulative backup is taken. On Tuesday, File 4 is added and no other data is modified since the previous full backup of Monday evening. Consequently, the cumulative backup on Tuesday evening copies only File 4. On Wednesday, File 5 is added. The cumulative backup taking place on Wednesday evening copies both File 4 and File 5 because these files have been added or modified since the last full backup. Similarly, on Thursday, File 6 is added. Therefore, the cumulative backup on Thursday evening copies all three files: File 4, File 5, and File 6. On Friday morning, data corruption occurs that requires data restoration using backup copies. The first step in restoring data is to restore all the data from the full backup of Monday evening. The next step is to apply only the latest cumulative backup, which is taken on Thursday

evening. In this way, the production data can be recovered faster because it needs only two copies of data — the last full backup and the latest cumulative backup.

### Recovery Considerations

The retention period is a key consideration for recovery. The retention period for a backup is derived from an RPO. For example, users of an application might request to restore the application data from its backup copy, which was created a month ago. This determines the retention period for the backup. Therefore, the minimum retention period of this application data is one month. However, the organization might choose to retain the backup for a longer period of time because of internal policies or external factors, such as regulatory directives.

If the recovery point is older than the retention period, it might not be possible to recover all the data required for the requested recovery point. Long retention periods can be defined for all backups, making it possible to meet any RPO within the defined retention periods. However, this requires a large storage space, which translates into higher cost. Therefore, while defining the retention period, analyze all the restore requests in the past and the allocated budget.

RTO relates to the time taken by the recovery process. To meet the defined RTO, the business may choose the appropriate backup granularity to minimize recovery time. In a backup environment, RTO influences the type of backup media that should be used. For example, a restore from tapes takes longer to complete than a restore from disks.

### Backup Methods

Hot backup and cold backup are the two methods deployed for a backup. They are based on the state of the application when the backup is performed. In a *hot backup*, the application is up-and-running, with users accessing their data during the backup process. This method of backup is also referred to as an *online backup*. A *cold backup* requires the application to be shut down during the backup process. Hence, this method is also referred to as an *offline backup*. The hot backup of online production data is challenging because data is actively used and changed. If a file is open, it is normally not backed up during the backup process. In such situations, an *open file agent* is required to back up the open file. These agents interact directly with the operating system or application and enable the creation of consistent copies of open files. In database environments, the use of open file agents is not enough, because the agent should also support a consistent backup of all the database components. For example, a database is composed of many files of varying sizes occupying several file systems. To ensure

a consistent database backup, all files need to be backed up in the same state. That does not necessarily mean that all files need to be backed up at the same time, but they all must be synchronized so that the database can be restored with consistency. The disadvantage associated with a hot backup is that the agents usually affect the overall application performance

Consistent backups of databases can also be done by using a cold backup. This requires the database to remain inactive during the backup. Of course, the disadvantage of a cold backup is that the database is inaccessible to users during the backup process.

A *point-in-time* (PIT) copy method is deployed in environments in which the impact of downtime from a cold backup or the performance impact resulting from a hot backup is unacceptable. The PIT copy is created from the production volume and used as the source for the backup. This reduces the impact on the production volume.

To ensure consistency, it is not enough to back up only the production data for recovery. Certain attributes and properties attached to a file, such as permissions, owner, and other metadata, also need to be backed up. These attributes are as important as the data itself and must be backed up for consistency.

In a disaster recovery environment, *bare-metal recovery* (BMR) refers to a backup in which all metadata, system information, and application configurations are appropriately backed up for a full system recovery. BMR builds the base system, which includes partitioning, the file system layout, the operating system, the applications, and all the relevant configurations. BMR recovers the base system first before starting the recovery of data files. Some BMR technologies — for example server configuration backup (SCB) — can recover a server even onto dissimilar hardware.

**Most organizations spend a considerable amount of time and money protecting their application data but give less attention to protecting their server configurations. During disaster recovery, server configurations must be re-created before the application and data are accessible to the user. The process of system recovery involves reinstalling the operating system, applications, and server settings and then recovering the data. During a normal data backup operation, server configurations required for the system restore are not backed up. *Server configuration backup* (SCB) creates and backs up server configuration profiles based on user-defined schedules. The backed up profiles are used to configure the recovery server in case of production-server failure. SCB has the**

capability to recover a server onto dissimilar hardware. In a server configuration backup, the process of taking a snapshot of the application server's configuration (both system and application configurations) is known as *profiling*. The profile data includes operating system configurations, network configurations, security configurations, registry settings, application configurations, and so on. Thus, profiling allows recovering the configuration of the failed system to a new server regardless of the underlying hardware.

There are two types of profiles generated in the server configuration backup environment: base profile and extended profile. The base profile contains the key elements of the operating system required to recover the server. The extended profile is typically larger than the base profile and contains all the necessary information to rebuild the application environment.

### Backup Architecture

A backup system commonly uses the client-server architecture with a backup server and multiple backup clients. Figure 10-4 illustrates the backup architecture. The backup server manages the backup operations and maintains the backup catalog, which contains information about the backup configuration and backup metadata. Backup configuration contains information about when to run backups, which client data to be backed up, and so on, and the backup metadata contains information about the backed up data. The role of a backup client is to gather the data that is to be backed up and send it to the storage node. It also sends the tracking information to the backup server. The storage node is responsible for writing the data to the backup device. (In a backup environment, a *storage node* is a host that controls backup devices.)

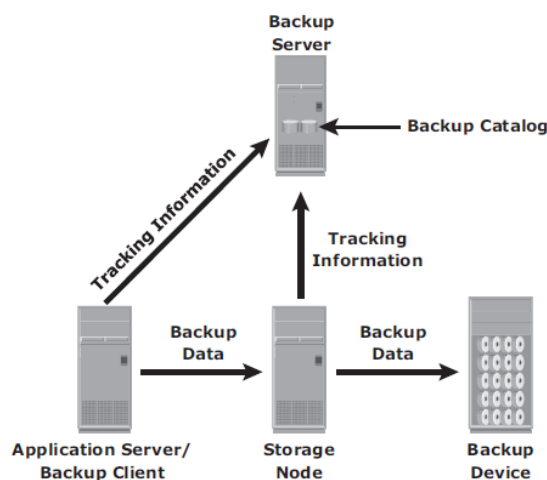

Figure 10-4: Backup architecture

The storage node also sends tracking information to the backup server. In many cases, the storage node is integrated with the backup server, and both are hosted on the same physical platform. A backup device is attached directly or through a network to the storage node's host platform. Some backup architecture refers to the storage node as the *media server* because it manages the storage device.

Backup software provides reporting capabilities based on the backup catalog and the log files. These reports include information, such as the amount of data backed up, the number of completed and incomplete backups, and the types of errors that might have occurred. Reports can be customized depending on the specific backup software used.

**Protecting backup metadata is an important aspect of backup. If the backup catalog is lost, data recovery will be a challenge. Therefore, an updated copy of the backup catalog should be maintained separately all the time.**

### Backup and Restore Operations

When a backup operation is initiated, significant network communication takes place between the different components of a backup infrastructure. The backup operation is typically initiated by a server, but it can also be initiated by a client. The backup server initiates the backup process for different clients based on the backup schedule configured for them. For example, the backup for a group of clients may be scheduled to start at 11:00 p.m. every day.

The backup server coordinates the backup process with all the components in a backup environment (see Figure 10-5). The backup server maintains the information about backup clients to be backed up and storage nodes to be used in a backup operation. The backup server retrieves the backup-related information from the backup catalog and, based on this information, instructs the storage node to load the appropriate backup media into the backup devices. Simultaneously, it instructs the backup clients to gather the data to be backed up and send it over the network to the assigned storage node. After the backup data is sent to the storage node, the client sends some backup metadata (the number of files, name of the files, storage node details, and so on) to the backup server. The storage node receives the client data, organizes it, and sends it to the backup device. The storage node then sends additional backup metadata (location of the data on the backup device, time of backup, and so on) to the backup server. The backup server updates the backup catalog with this information. After the data is backed up, it can be restored when required. A restore process must be manually initiated from the client. Some backup software has a separate application for restore operations. These

restore applications are usually accessible only to the administrators or backup operators. Figure 10-6 shows a restore operation.

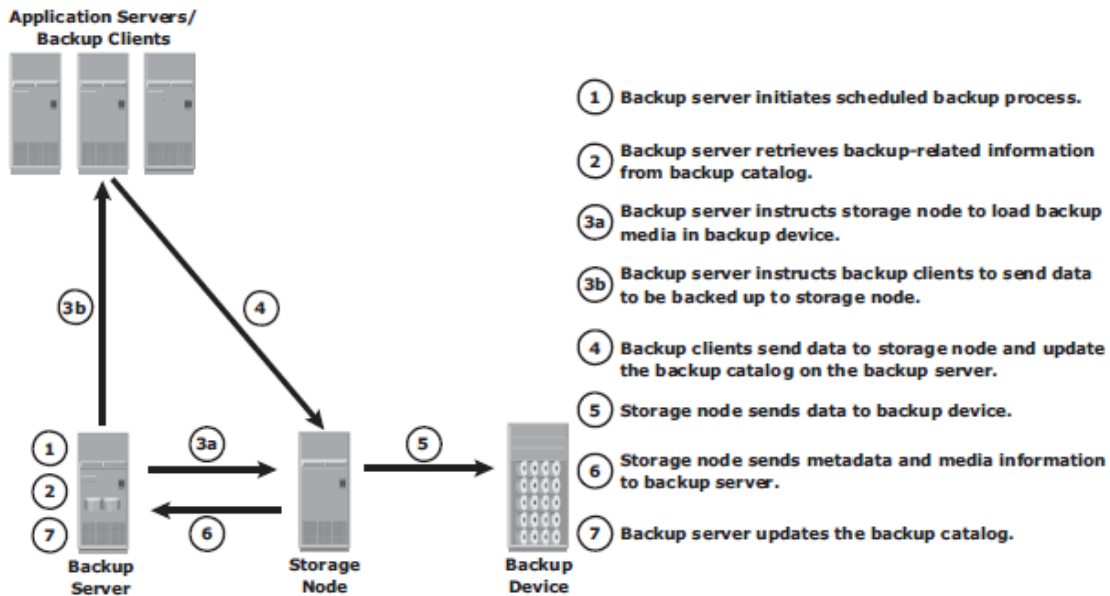

Figure 10-5: Backup operation

Upon receiving a restore request, an administrator opens the restore application to view the list of clients that have been backed up. While selecting the client for which a restore request has been made, the administrator also needs to identify the client that will receive the restored data. Data can be restored on the same client for whom the restore request has been made or on any other client. The administrator then selects the data to be restored and the specified point in time to which the data has to be restored based on the RPO. Because all this information comes from the backup catalog, the restore application needs to communicate with the backup server.

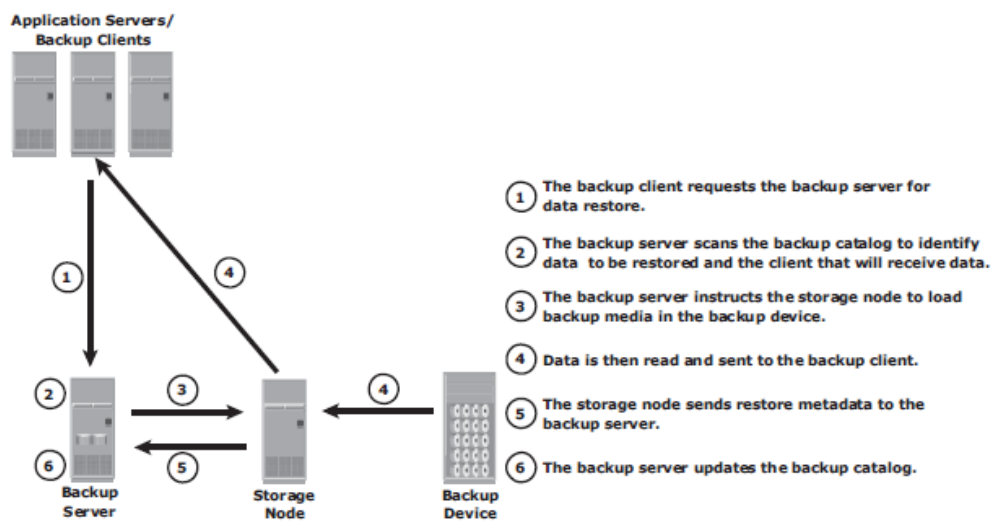

Figure 10-6: Restore operation

The backup server instructs the appropriate storage node to mount the specific backup media onto the backup device. Data is then read and sent to the client that has been identified to receive the restored data. Some restorations are successfully accomplished by recovering only the requested production data. For example, the recovery process of a spreadsheet is completed when the specific file is restored. In database restorations, additional data, such as log files, must be restored along with the production data. This ensures consistency for the restored data. In these cases, the RTO is extended due to the additional steps in the restore operation.

### Backup Topologies

Three basic topologies are used in a backup environment: direct-attached backup, LAN-based backup, and SAN-based backup. A mixed topology is also used by combining LAN-based and SAN-based topologies.

In a *direct-attached backup*, the storage node is configured on a backup client, and the backup device is attached directly to the client. Only the metadata is sent to the backup server through the LAN. This configuration frees the LAN from backup traffic. The example in Figure 10-7 shows that the backup device is directly attached and dedicated to the backup client. As the environment grows, there will be a need for centralized management and sharing of backup devices to optimize costs. An appropriate solution is required to share the backup devices among multiple servers. Network-based topologies (LAN-based and SAN-based) provide the solution to optimize the utilization of backup devices.

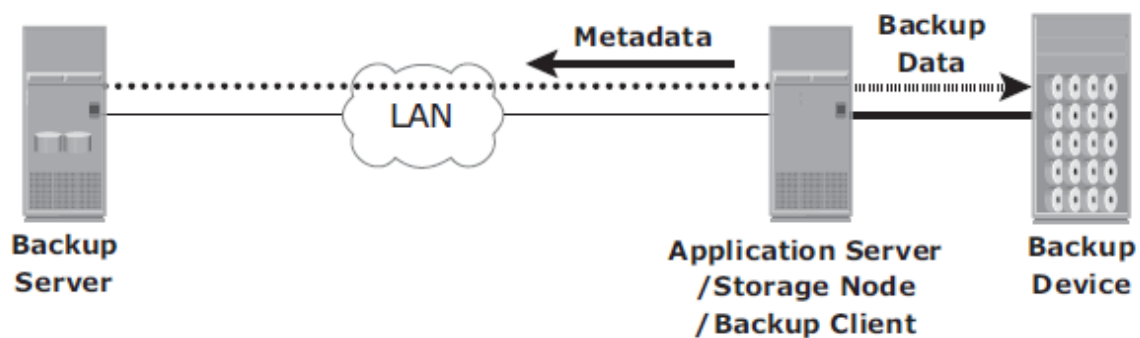

**Figure 10-7:** Direct-attached backup topology

In a *LAN-based backup*, the clients, backup server, storage node, and backup device are connected to the LAN. (see Figure 10-8). The data to be backed up is transferred from the backup client (source) to the backup device (destination) over the LAN, which might affect network performance.

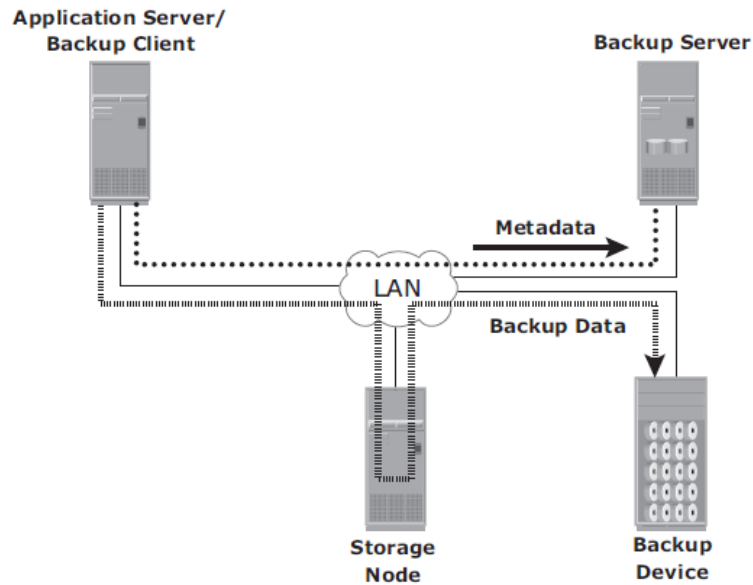

Figure 10-8: LAN-based backup topology

This impact can be minimized by adopting a number of measures, such as configuring separate networks for backup and installing dedicated storage nodes for some application servers.

A *SAN-based backup* is also known as a *LAN-free backup*. The SAN-based backup topology is the most appropriate solution when a backup device needs to be shared among clients. In this case, the backup device and clients are attached to the SAN. Figure 10-9 illustrates a SAN-based backup. In this example, a client sends the data to be backed up to the backup device over the SAN. Therefore, the backup data traffic is restricted to the SAN, and only the backup metadata is transported over the LAN. The volume of metadata is insignificant when compared to the production data; the LAN performance is not degraded in this configuration.

The emergence of low-cost disks as a backup medium has enabled disk arrays to be attached to the SAN and used as backup devices. A tape backup of these data backups on the disks can be created and shipped offsite for disaster recovery and long-term retention.

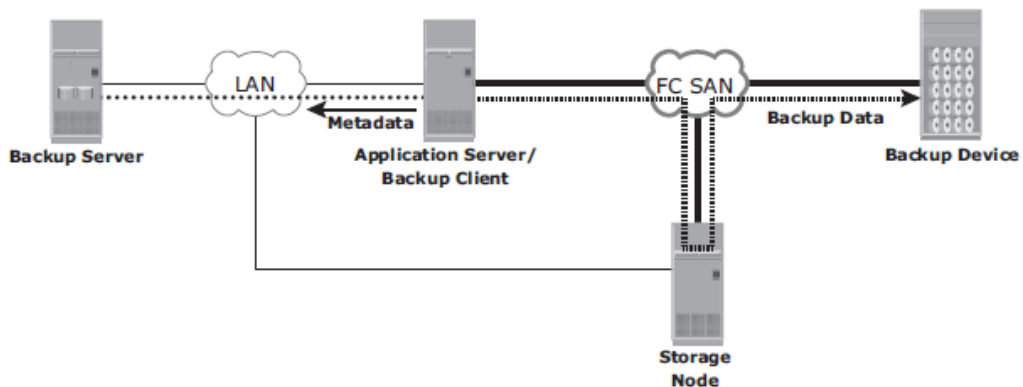
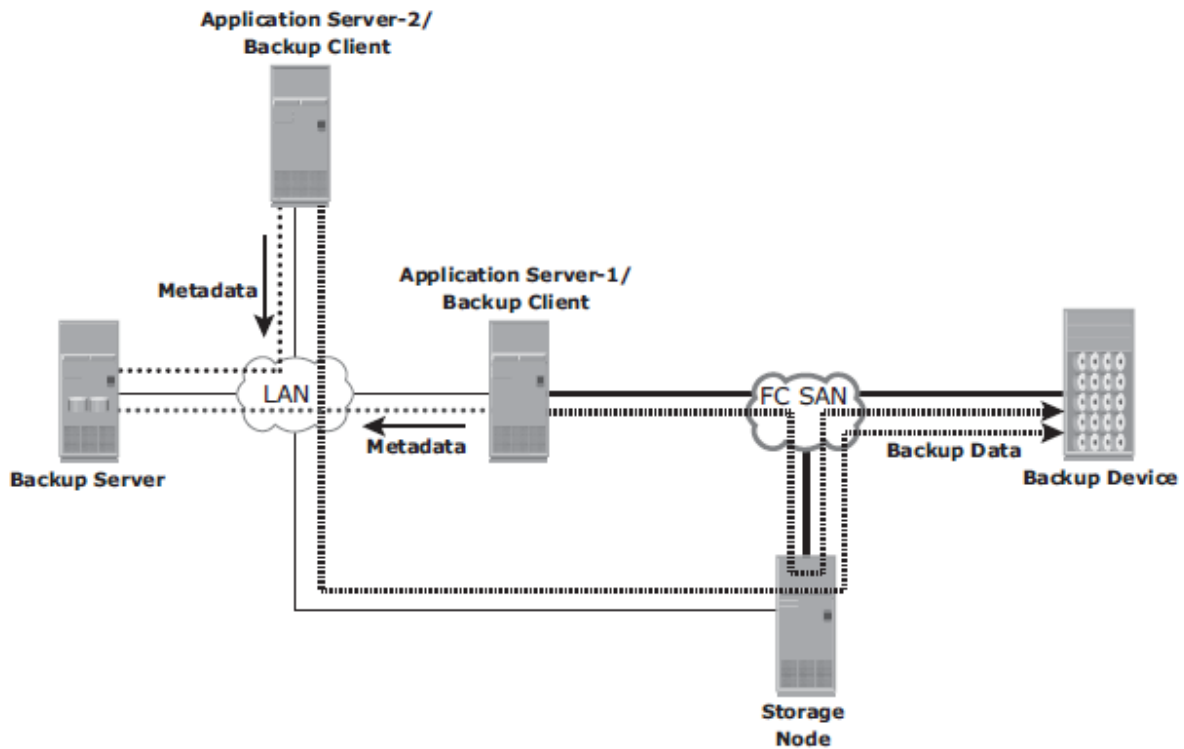

Figure 10-9: SAN-based backup topology

The *mixed topology* uses both the LAN-based and SAN-based topologies, as shown in Figure 10-10. This topology might be implemented for several reasons, including cost, server location, reduction in administrative overhead, and performance considerations.



**Figure 10-10:** Mixed backup topology

### Backup in NAS Environments

The use of a NAS head imposes a new set of considerations on the backup and recovery strategy in NAS environments. NAS heads use a proprietary operating system and file system structure that supports multiple file-sharing protocols. In the NAS environment, backups can be implemented in different ways: server based, serverless, or using Network Data Management Protocol (NDMP). Common implementations are NDMP 2-way and NDMP 3-way.

#### Server-Based and Serverless Backup

In an *application server-based backup*, the NAS head retrieves data from a storage array over the network and transfers it to the backup client running on the application server. The backup client sends this data to the storage node, which in turn writes the data to the backup device. This results in overloading the network with the backup data and using application server resources to move the backup data. Figure 10-11 illustrates server-based backup in the NAS environment.

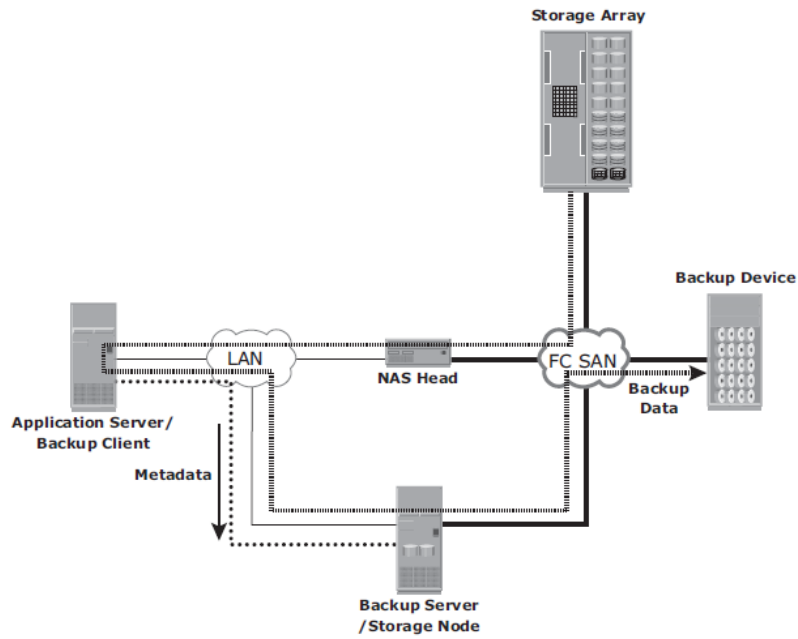

Figure 10-11: Server-based backup in a NAS environment

In a *serverless backup*, the network share is mounted directly on the storage node. This avoids overloading the network during the backup process and eliminates the need to use resources on the application server. Figure 10-12 illustrates serverless backup in the NAS environment. In this scenario, the storage node, which is also a backup client, reads the data from the NAS head and writes it to the backup device without involving the application server. Compared to the previous solution, this eliminates one network hop.

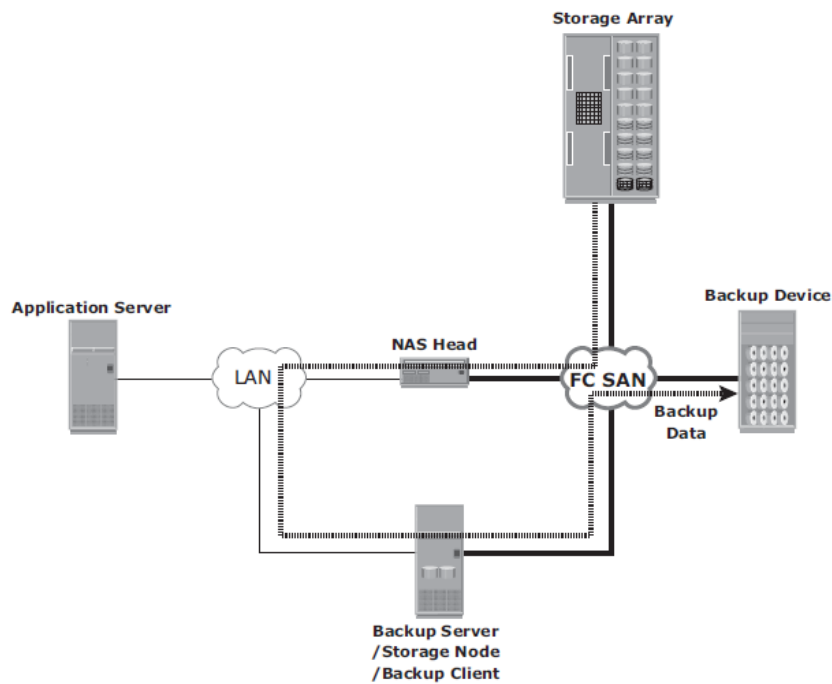
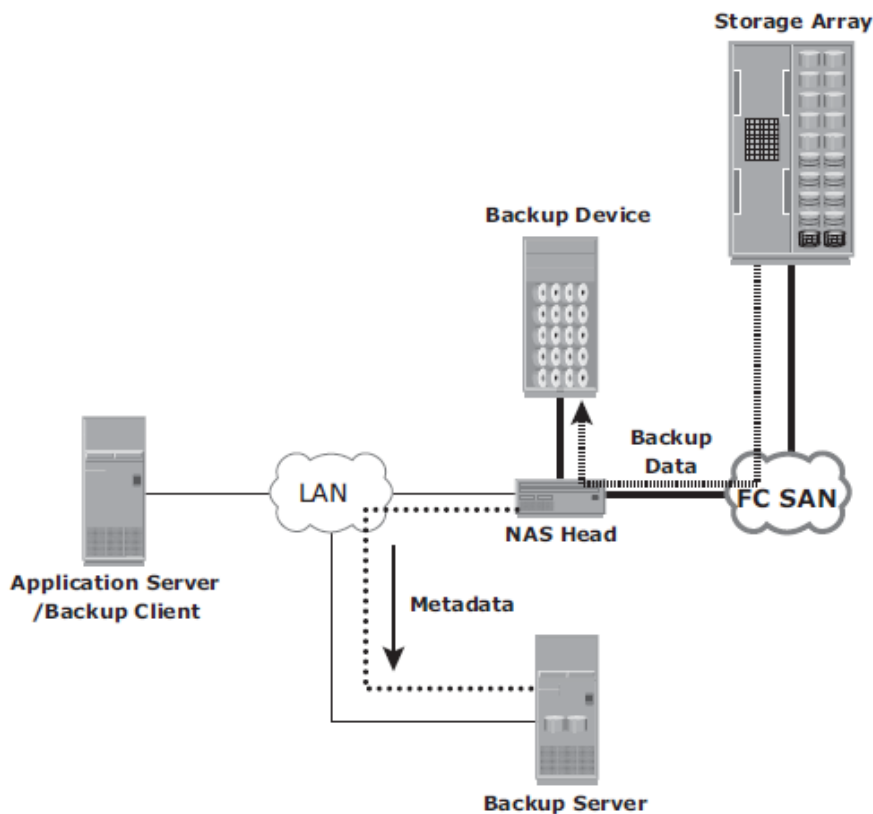

Figure 10-12: Serverless backup in a NAS environment

### NDMP-Based Backup

*NDMP* is an industry-standard TCP/IP-based protocol specifically designed for a backup in a NAS environment. It communicates with several elements in the backup environment (NAS head, backup devices, backup server, and so on) for data transfer and enables vendors to use a common protocol for the backup architecture. Data can be backed up using NDMP regardless of the operating system or platform. Due to its flexibility, it is no longer necessary to transport data through the application server, which reduces the load on the application server and improves the backup speed.

NDMP optimizes backup and restore by leveraging the high-speed connection between the backup devices and the NAS head. In NDMP, backup data is sent directly from the NAS head to the backup device, whereas metadata is sent to the backup server. Figure 10-13 illustrates a backup in the NAS environment using NDMP 2-way. In this model, network traffic is minimized by isolating data movement from the NAS head to the locally attached backup device. Only metadata is transported on the network. The backup device is dedicated to the NAS device, and hence, this method does not support centralized management of all backup devices.



**Figure 10-13:** NDMP 2-way in a NAS environment

In the *NDMP 3-way* method, a separate private backup network must be established between all NAS heads and the NAS head connected to the backup device. Metadata and NDMP control data are still transferred across the public network. Figure 10-14 shows a NDMP 3-way backup.

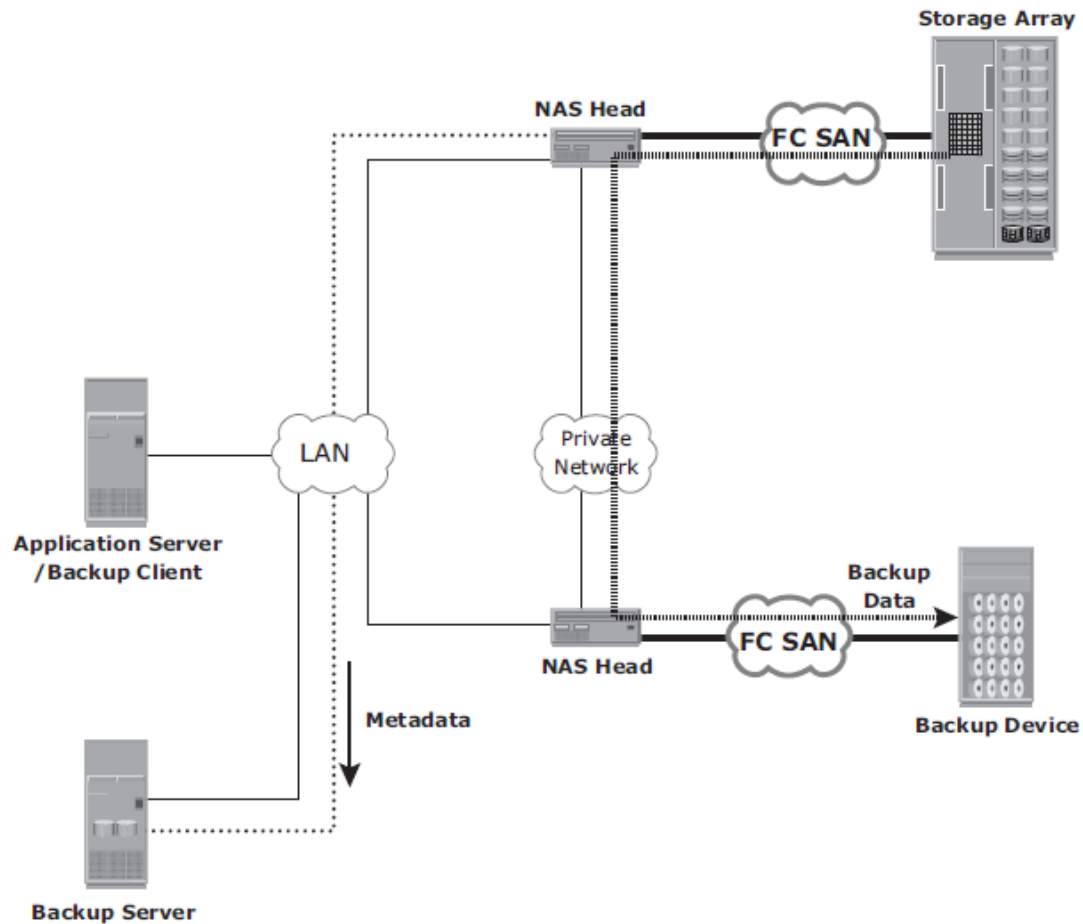

**Figure 10-14:** NDMP 3-way in a NAS environment

An NDMP 3-way is useful when backup devices need to be shared among NAS heads. It enables the NAS head to control the backup device and share it with other NAS heads by receiving the backup data through the NDMP.

---

**Question Bank**

- 1) Explain the failure analysis in BC. Mention some important BC technology solution
- 2) With neat diagram, Elaborate Business Continuity Planning Life Cycle
- 3) Outline different metrics used in measuring information availability
- 4) Discuss causes for information unavailability and the consequences of downtime
- 5) Explain Backup and Restore operations with neat diagram.
- 6) Illustrate different Backup Topologies.
- 7) Elaborate on Backup Purpose and Backup Considerations.
- 8) Explain about Backup in NAS Environments.
- 9) Explain about Backup Methods and Backup Architecture with the help of a neat diagram.
- 10) Elaborate on the Backup Granularity.